

CATALOG &
TECHNICAL
GUIDE 2020.1



SOLID END MILLS

> 30,000

STANDARD PRODUCTS



> 75

COUNTRIES



> 4,100

DEDICATED EMPLOYEES



Headquartered in Fagersta, Sweden and present in more than 75 countries, Seco Tools is a leading global provider of metal cutting solutions for milling, stationary tools, holemaking and tooling systems.

For more than 80 years, the company has provided the technologies, processes and support that manufacturers depend on for maximum productivity and profitability. For more information on how Seco's innovative products and expert services bring success to manufacturers across all industry segments, please visit www.secotools.com.

General	Index..... 2	
	Product introduction and technical information 3-22	P M
Universal	Product information and cutting data..... 23-152	K N
		S H
		TS/P
Steel and cast iron	Product information and cutting data 153-173	P
		K
Stainless steel and S-materials (HRSA and Titanium alloys)	Product information and cutting data 174-260	M
		S
Non-ferrous	Product information and cutting data..... 261-305	N
		TS
Hardened steels	Product information and cutting data..... 306-342	H
Plastic and CFRPs	Product information and cutting data..... 343-393	TS&TP
Graphite	Product information and cutting data..... 394-408	GR
Technical information	Recalculations 411-418	
	Cutting calculations and definitions..... 419-420	
SMG	Workpiece Materials – SMG (Seco material group) 421-433	

H

HK/HKM 120-130

J

J28 392-393
 J29 116-117
 J36 118-119
 J93 390
 J93F 391
 JC840 347-348
 JC845 349-350
 JC850 351-352
 JC860 353-354
 JC870 355-359
 JC871 360-364
 JC875 365-367
 JC876 368-370
 JC877 371-373
 JC880 374-375
 JC885 376-377
 JC898 379
 JC899 381-382

JCO

JCO710 256-260

JCD

JD620 397-398
 JD630 399-400
 JD640 401-402
 JD660 403-404

JH

JH112 167-169, 324-326
 JH120 314-315
 JH130 316-317
 JH142 162-164, 321-323
 JH150 170-171, 327-328
 JH160 172-173, 329-330
 JH40 285, 287
 JH410 292-293
 JH421 288-291
 JH440 296-297
 JH450 298-299
 JH460 300-301
 JH710 240-241
 JH720 250-251
 JH721 252-253
 JH722 254-255
 JH730 244-245
 JH740 238-239
 JH770 236-237
 JH780 248-249
 JH790 242
 JH830 294-295
 JH910 103-105
 JH930 107-109, 318-320
 JH970 110, 165

JHF

JHF180 313

JHF181 312
 JHF980 112-114

JHP

JHP170 309-311
 JHP490 281-284
 JHP750 217-219
 JHP760 220-222
 JHP770 223-226, 228-230
 JHP780 231-235
 JHP951 159-161
 JHP993 156-158
 JHP994 246-247

JM

JM403, JM404, JM406 302-303
 JM413, JM416 304-305

JMB

JMB112 339-342
 JMB542 144
 JMB562 147-148
 JMB563 151-152
 JMB642, JMB662 407-408

JME

JME142 332-336
 JME144 337-338
 JME542, JME562 134, 136, 143, 145-146, 140-150
 JME564 137-138
 JME642 405-406

JPD

JPD850 384-385
 JPD880 386-387
 JPD890 388-389

JS

JS412 265-267
 JS413 268-271
 JS452 271-276, 278-279
 JS453 276-280
 JS506 97-99
 JS509 100-102
 JS512 30-34
 JS513 35-40
 JS514 41-45
 JS520 81-83
 JS522 85-86
 JS532 88-90
 JS533 91-93
 JS534 94-96
 JS553 46-55
 JS554 56-69, 72-74
 JS564 75-77
 JS565 78-80
 JS720 206-212
 JS730 213-216
 JS754 178-194
 JS755 195-205

V

V31 131-132



WELCOME TO SOLID MILLING

JABRO was founded in 1976 in Lottum, Netherlands.

JABRO is Seco's competence centre for solid milling solutions, and has the global responsibility for Research & Development, Manufacturing and Application Engineering.

Seco JABRO's products provide the world market with a wide range of standard tools and custom tool solutions, including reconditioning, mainly for General Engineering, Aerospace, Energy, Medical and Mould & Die customers.

Advanced manufacturing technology and an environmental focus, ensures Seco's sustainable development and production of products that successfully respond to market demands in milling operations for both ferrous and non-ferrous materials.

- General Engineering
- Mould & Die
- Aerospace
- Medical
- Power energy
- 3C segment (Computer Customer Electronics and Communications)

JABRO® – SOLID²



Jabro-Solid² is a range of solid carbide end mills for applications in general machining, offering flexibility, speed and cost efficiency. Jabro-Solid² is available in a diameter range of $\varnothing 1$ - $\varnothing 32$ mm and in inch $\varnothing 1/32$ - 1 1/4.

Jabro-Solid² also includes a group of dedicated advanced roughing tools (JS564 and JS565).

The 564 and 565 offer excellent performance when applied in well defined tool paths with constant arc of contact with high cutting speed and high cutting depth applications (advanced roughing).

For the complete range of JS500 series tools all chamfer ($c^{\circ}45^{\circ}$) have the following tolerances: $c = DC \leq 3 = +0,01$, $3 < DC \leq 6 = +0,02$, $6 < DC \leq 10 = +0,03$,

$10 < DC \leq 14 = +0,04$, $14 < DC \leq 18 = +0,05$, $18 < DC \leq 24 = +0,06$,

All Jabro-Solid² product codes begin with JS.

Please see page 8 for a grouped overview of JS² products.

JABRO® – HSM/TORNADO (High speed machining)



These tools are characterized by high precision tolerances, short cutting lengths, reduced necks and significant core diameters, maximizing rigidity. These tools have been developed to excel in peripheral milling and copy milling machining methods.

Please see page 8 for a grouped overview of HSM/TORNADO (high speed machining) products.

JABRO® – HPM (High performance machining)



Optimized endmills are dedicated for original equipment manufacturers and first-tier suppliers where large batches of a single component have to be machined and where processes need to be fully optimized to reduce cycle times, reducing costs per part.

Please see page 9 for a grouped overview of HPM (high performance machining) products.

JABRO® – HFM (High feed machining)



High feed machining is the first choice for applications with deep and shallow workpiece features, 3D profiling for mold & die applications and machining in unstable conditions. High feed tools excel in plunge milling machine methods. Please see page 9 for a grouped overview of HFM (high feed machining) products.

JABRO® – MINI (Micro machining)



Seco's range of micro solid carbide end mills consists of square end mills and ballnose cutters with small cutting diameters. Universal tools are applicable for common workpiece materials and specific tools are dedicated for graphite and hardened-steel applications. All tools have a thin layered coating for optimal performance in small-sized applications. Please see page 9 for a grouped overview of MINI (micro machining) products.

JABRO® – DIAMOND



Available in a variety of geometries and an extensive diameter range, these tools feature the best possible substrate to ensure the perfect adhesion of the diamond coating across a range of cutting parameters. Overall, these end mills significantly increase productivity and lower tooling costs by requiring fewer tool changes and being able to produce precision parts at high feed rates. Please see page 9 for a grouped overview of DIAMOND (diamond coated) products.

JABRO® – COMPOSITE



It consists of diamond-coated and uncoated solid carbide and PCD end mills incorporating different geometries as well as with PCD-brazed cutting edges. This is a product range offering optimized tools for difficult cutting conditions on challenging workpiece materials.

Please see page 9 for a grouped overview of COMPOSITE (JC) products.



JABRO® – VHM (General engineering)







Includes universal coated and uncoated endmills, a range of products dedicated for machining plastics and aluminum, chamfer end mills and conical tools. These products consist of high-quality grades and coatings for predictable and premium tool life.

Please see page 10 for a grouped overview of VHM (general engineering) products.



Product family	Technology	Product	1xx	4xx	5xx	6xx	7xx	8xx	9xx
Jabro-Solid ²	General machining	JS		■	■		■		
Jabro - HPM	High performance machining	JHP	■	■			■		■
Jabro - HFM	High feed machining	JHF	■						■
Jabro - Mini	Micro machining	JM	■	■	■	■			■
Jabro - HSM/Tornado	High speed machining	JH	■	■			■		■
Jabro - Diamond	Graphite machining	JD				■			
Jabro - Composites	Composite machining	JC, JPD						■	
Jabro - VHM	General machining	J		■					■
Jabro-HSS-E	General machining	JCO					■		
SMG									
P1-8					■				■
P11-12					■				■
M1-3					■		■		
M4-5					■		■		
K1-7					■				■
S1-3					■		■		
S11-13					■		■		
H			■		■				
N1				■	■				
N2-3				■	■				
N11				■	■				
TS				■				■	
TP				■				■	
GR						■			
For further explanation on SMG (Seco material group) please see page 421									

	Page	Family name	Name	P1-8	P11-12	M1-3	M4-5	K1-7	N1	N2-3	N11	S1-3	S11-13	H3-31	TS1	TS2-3	TS4	TP1	TP2-3	TP4	Honeycomb	GR		
	30-34	JS*	JS512	●	○	●	○	●	○	○	○	○	●	○	○							○		
	35-40		JS513	●	○	●	○	●	○	○	○	○	○	●	○	○							○	
	41-45		JS514	●	○	○	○	●	○	○	○	○	○	●	○	○							○	
	46-55		JS553	●	●	●	●	●	●	●	●	●	●	●	●	●	●							○
	56-74		JS554	●	●	●	●	●	●	●	●	●	●	●	●	●	●							○
	265-267		JS412							●	●						●			●				
	268-270		JS413							●	●						●			●				
	271-275		JS452							●	●						●			●				
	276-280		JS453							●	●						●			●				
	81-83		JS520	●	○	○	○	●	○	○	○	○	○	○	●	○	○							○
	85-86		JS522	●	●	●	●	●	●	●	●	●	●	○	●		●							○
	87-90		JS532	●	○	●	●	●	●	●	●	●	●	○	●		●							○
	91-93		JS533	●	○	●	●	●	●	●	●	●	●	○	●		●							○
	94-96		JS534	●	○	●	●	●	●	●	●	●	●	○	●		●							○
	97-99		JS506	●	○	●	●	●	●	●	●	●	●	○	●		●							○
	100-102		JS509	●	○	●	●	●	●	●	●	●	●	○	●		●							○
	75-77		JS564	●	○	●	●	●	●	●	●	●	●	○	●		●							○
	78-80		JS565	●	○	●	●	●	●	●	●	●	●	○	●		●							○
	206-212		JS720				●	●		●		●					●				●			
	213-216		JS730				●	●									●							
178 - 194	JS754		○	●	●																			
195 - 205	JS755		○	●	●																			
285-287	JH40							●		●					●									
	170-172, 328-330	HSM/TORNADO	JH112					●						●										
	314-315		JH120						●						●									
	316-317		JH130						●						●									
	164-166, 324-326		JH142	●	●				●						●									
	170, 327		JH150						●						●									
	172, 329		JH160	●	○										●									
	292-293		JH410							●		●					●							
	288-291		JH421							●		●					●				●			
	296-297		JH440							●	●	●					●				●			
	298-299		JH450							●	●	●					●				●			
	300-301		JH460							●	●	●					●				●			
	240-241		JH710							●		●		●	●									
	250-251		JH720			●	●			●		●	○	●	●		●					●		
	252-253		JH721							●		●		●	●									
	254-255		JH722							●		●		●	●									
	244-245		JH730							●		●		●	●									
	238-239		JH740							●		●		●	●									
	236-237		JH770							●		●		●	●									
	248-249		JH780							●		●		●	●									
	242-243		JH790							●		●		●	●									
	294-295		JH830								●													
	103-106		JH910	●	○	●	●	●						●	●							●		●
	107		JH930	●	○			●						●	●	●								
	110-111, 168-169		JH970	●	○	●	●							●	●									

● Preferred choice, ○ Alternative choice

	Page	Family name	Name	P1-8	P11-12	M1-3	M4-5	K1-7	N1	N2-3	N11	S1-3	S11-13	H3-31	TS1	TS2-3	TP1	TP2-3	TS2/TP2+N1	TS2/TP2+S12	Honeycomb	GR	
	309-311	HPM	JHP170											•									
	217-219		JHP750										•	•									
	220-222		JHP760			•	•																
	223-230		JHP770											•									
	231-235		JHP780											•									
	281-284		JHP490							•	•												
	159-161		JHP951	•	○				•														
	156-158		JHP993	•	○				•														
246-247	JHP994											•	•										
	312-313	HFM	JHF181	○	○			•				•	•	•									
	112-115		JHF980	•	○	•	•	•					•	•	•	○							
	339 - 342	MINI	JMB112											•									
	332 - 336		JME142												•								
	337 - 338		JME144												•								
	302-303		JM403/404/406							•	•												
	304-305		JM413/416							•	•	•					•		•				
	144		JMB542	•	•	•	•			○	○	○	○	•	○								○
	147 - 148		JMB562	•	•	•	•			○	○	○	○	•	○								○
	151- 152		JMB563	•	•	•	•			○	○	○	○	•	○								○
	134		JME542	•	•	•	•			○	○	○	○	•	○								○
	140-141		JME562	•	•	•	•			○	○	○	○	•	○								○
	137- 139		JME564	•	•	•	•			○	○	○	○	•	○								○
	407-408		JMB642																				•
	407- 408		MINI DIAMOND	JMB662																			•
405-406	JME642																				•		
	397-398	DIAMOND	JD620																			•	
	399-400		JD630																				•
	401-402		JD640																				•
	403-404		JD660																				•
	347-348	COMPOSITE	JC840																•				
	349-350		JC845																	•		•	
	351-352		JC850																	•		•	
	353-354		JC860																	•		•	
	355-359		JC870																	•		•	
	360-364		JC871																	•		•	
	365-367		JC875																	•		•	
	368-370		JC876																	•		•	
	371-373		JC877																	•		•	
	374-375		JC880																	•		•	
	376-377		JC885																	•		•	
	379		JC898																	•		•	
	381 - 382		JC899																		•	•	
	384-385		PCD	JPD850																	•		•
	386-387			JPD880																	•		•
	388-389			JPD890																	•		•

• Preferred choice, ○ Alternative choice

	Page	Family name	Name	P1-8	P11-12	M1-3	M4-5	K1-7	N1	N2-3	N11	S1-3	S11-13	H3-31	TS1	TS2-3	TS4	TP1	TP2-3	TP4	Honeycomb	GR	
	392-393	VHM	J28												•								
	118-119		J36	○	•	○	○	○	○	•	•	○	○			○			○				
	120-130		HK/HKM	•		•	•	•	•	•	○		•	•		•			•				
			TDM																				
	131-132		V31	•		•		•	•	•	•		•	•		•				•			•
	116-117		J29	•	•	•	•	•	•	•	•	•	•	•		•				•			•
	390-391		J93F													•			•				
	256-260	Hss-Co	JCO710			•	•					•											

• Preferred choice, ○ Alternative choice

Code key

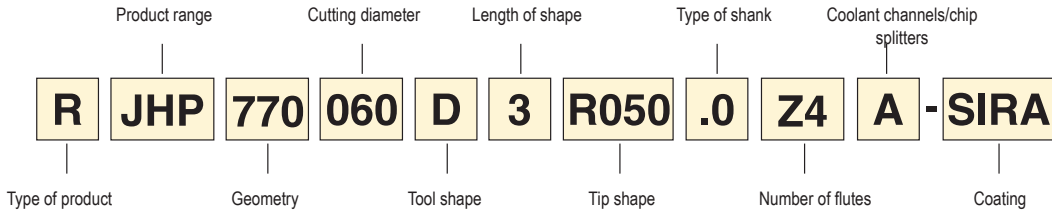

Product range

- J = JABRO® VHM
- JC = JABRO® Composites
- JD = JABRO® Diamond
- JH = JABRO® HSM/Tornado
- JHF = JABRO® HFM
- JHP = JABRO® HPM
- JM = JABRO® Mini
- JS = JABRO® SOLID²
- JPD = JABRO® PCD
- JCO = JABRO® HSS-Co

Type of product

- BLANK = Standard (catalogue) product
- R = Reconditioned product (complete)
- RK = Reconditioned product (frontal)

Length of shape

A single digit that gives an indication of the length of the cutter compared to other products with the same cutting geometry. This replaces the previous L, XL, SL, K, and other versions. For most products 1=K, 2=N, 3=L, 4=XL

Number of flutes

This figure indicates the number of flutes in the cutter. For example; PCEDC2= 2 flutes, PCEDC6 = 6 flutes

Cutting diameter

Metric = 3 digit code (in case of 4 digit code – xx,xx mm)
 Imperial = a dot followed by a 3 digit code
 For example: (050 = metric, 5 mm) / (.500 = imperial, ½ inch)

Coolant channels/chip splitters

- BLANK = No coolant channels
- A = Internal coolant channel(s)
- C = Chip splitters

Geometry

Geometry
 A three-digit combination specifying the cutting geometry. For example; 111, 950, 553, 514, etc.

Type of shank

- Indicates the shank types that are available.
- .0 = Cylindrical
- .3 = Weldon
- .5 = Whistle Notch
- .9 = Safe-Lock

Tip shape						Coating
Sharp 	Ball-nose 	Corner radius 	Concave radius 	Chamfer 	High feed 	4 character code specifying the coating on the cutter. MEGA = MEGA MT = MEGA-T M64 = MEGA-64 M64T = MEGA-64-T TRI = TRIBON SIRA = SIRON-A HEMI = HEMI DIA = DIAMOND DURA = DURA NXT = NXT HXT = HXT STAX = STAX
S	B	R...	K...	C	H	
Size of radius for convex and concave radius tipped products .000 = For metric products the tip shape is shown by a three-digit figure. By dividing this figure by 100 you will get the actual corner radius size in millimetres. .000 = For imperial products the tip shape is shown by a dot, followed by a three-digit figure. This figure actually shows the size of the corner radius in inch (e.g. R.100 would indicate a radius of 0.100 inch).						

Tool shape						
(DC = DMM)		(DC < DMM)				(DC > DMM)
D	E	F	G	J	N	P

Custom tools

A significant part of Seco’s offer are “Custom Tools”.

Seco engineers work in close cooperation with customers to provide the best possible solution to specific machining challenges where the demands stretch beyond standard tools.



Modified tools

Seco offers a quick delivery solution for standard tools requiring modification to meet specific dimensional requirements.

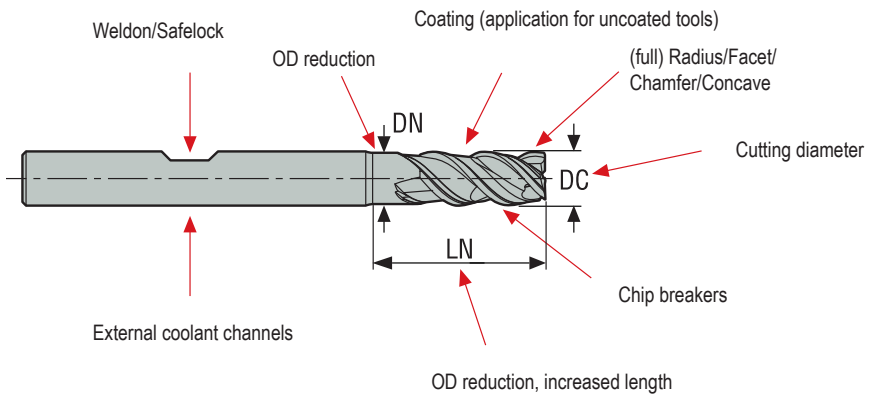

For further information on custom, modified and reconditioned tools please contact your local Seco representative.

Reconditioning cuts cost and tools inventory



Seco's modern carbide tools offer remarkable performance by utilizing the best combinations of carbide substrates with highly wear resistant coatings, optimized cutting geometry and controlled edge preparation. However good a tool is, as part of its function, it will eventually show signs of wear on the cutting edge. Controlling this wear and the timely replacement of the tool will allow the used tool to be reconditioned, thus reducing tool investment costs.

At Seco, your solid carbide tools are reconditioned using the same advanced technology and care that we use to manufacture our new products.

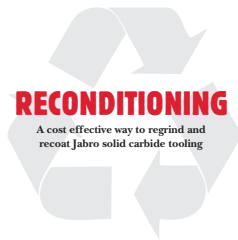

Your benefits from reconditioning

- Manufactured to Seco's high standards with the original Seco geometry, edge preparation and coating processes.
- Savings on tooling costs by repeated use of the same solid carbide tool.
- Our easy to use and free 'reconditioning box' includes a pre-prepared delivery note.
- Free, reliable collection on the following day when you call your Seco contact for pick up.
- An easy process due to the package service, reconditioning box and prepared delivery note. Delivery via the normal Seco channels.
- Safe transportation and storage of the reconditioned tools by packaging them in similar packaging as new tools.
- A new packaging label is included.
- Work towards greener and cleaner environment. -Seco's processes are globally certified with ISO14001.
- Guaranteed quality, as all processes are ISO9001 certified.

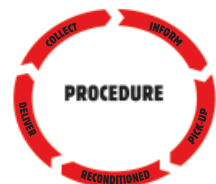

Basic operations:

- Face milling
- Slot milling
- Side milling
- Copy milling

Definitions, basic operations:

Face milling:

Operation where the tool is in engagement with less than 180° arc of contact.

Tool engagement:
Small a_p and large a_e .

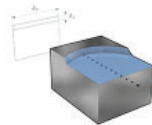

Slot milling:

Operation where the full diameter is in engagement, a_e is equal to DC and a_p up to 2 times DC depending on the machining strategy in use.

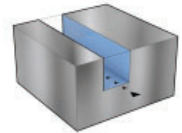

Side milling:

Operation where the side of the tool is in engagement, a_p is large and a_e is small.

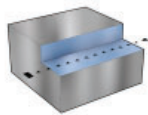

Copy milling:

Operation where the radius is in engagement. a_p and a_e are both small.

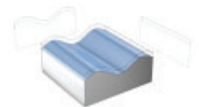

Advanced machining methods:

- Ramping
- Advanced roughing / Optirough
- Helical interpolation
- Trochoidal milling
- Push-pull
- Plunge milling
- Z-leveling
- Drilling

Definitions, advanced machining methods:

Ramping:

Opening up a pocket by making a Z axis at an angle.

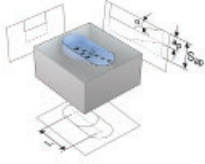

Helical interpolation ramping:

Opening a pocket by making a circular movement with the tool while ramping in Z axis.

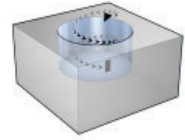

Trochoidal:

Opening a slot by using side milling, making a partial circular movement in X- or Y-axis. (changing slot milling into side milling).

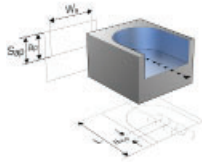

Push-pull:

Machining a 3D form by making a down and up copying movement following the profile of the form.

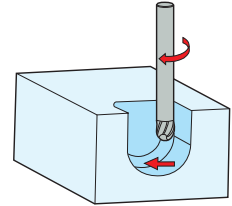

Plunge milling:

Opening up a deep slot by using drilling (Z) axis.

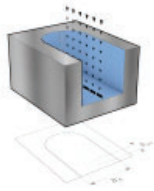

Z-leveling:

Machining a surface by making a small drilling or ramping in Z axis then opening the pocket with X and Y movements.

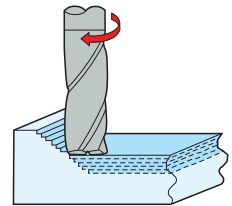

Drilling:

Making a hole with movement in Z axis.

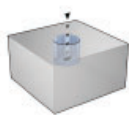

Advanced roughing/Optirough

Well defined tool paths with constant arc of contact for reliable roughing of simple & complex shapes.

The large axial depths (a_p) & small radial depths (a_e) of cut combined with high feeds per tooth (f_z) and cutting speeds (V_c) results in high productivity.

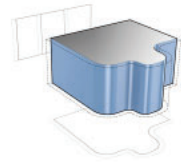

Definitions:

Machining strategies:

- General machining
- High speed machining
- High performance machining
- High feed machining
- Micro machining
- Advanced roughing / Optirough

Definitions, machining strategies:

General machining:

A machining strategy for general use. $a_e - a_p$ ratio can vary depending on the operation.

Tool characteristics: Tools have relatively long cutting lengths and thin core diameters. There are no high requirements on the tolerances.

Machine requirements: There are no special machine requirements needed.

With basic CNC technology, difficult advanced machining methods are not possible.

Average results will be reached on metal removal rate Q (cm³/min).

The application area usually includes small batch sizes and a wide range of materials.

High speed machining:

Is a machining strategy where a combination of a small radial depth of cut and high cutting speed and table feeds are used.

Depending on the method a high metal removal and a low R_a value can be reached. Typical for this strategy are the low cutting forces, less heat build up in tool and workpiece, less burr formation and high dimensional accuracy on the workpiece.

With HSM (High Speed Machining) you achieve high metal removal rate and/or surface finish by using a much higher cutting speed compared to general machining.

Tool characteristics: Stable, (thick core diameter and a short cutting length) clear and well formed chip space for good chip evacuation, coating.

Machine requirements: Quick CNC control, high RPM, quick transmission to the axis.

The applications area is: Mould & Die industry on pre-finishing and finishing operations in hardened steel (48-62 HRc) in a short lead time.

This technique can also be applied in most other materials when using the right tool and advanced machining method.

High Performance Machining:

Is a machining strategy where very high metal removal rates can be achieved. Typical for this strategy is that a_e is 1 times DC and a_p is 1 to 1½ times DC depending the workpiece material.

With HPM (High Performance Machining) you achieve an extremely high metal removal rate by using a much higher chip load than in general machining.

Tool characteristics: Specially developed chip formers in the flute of the tool, tip protection with a small 45° face or corner radius, special smooth formed chip space and coating, with or without Weldon shank.

Machine requirements: High stability, high power requirements, CNC control, rigid clamping system.

The application areas are: Operations in a mass production environment where production time/lead time is of great importance or on single products where a high metal removal rate Q (cm³/min.) is required.

High Feed Machining:

Is a machining strategy where high feed rates can be reached with large radial engagements (a_e) in combination with a small a_p .

With HFM (High Feed Machining) you achieve high metal removal rates and/or surface finish by using a much higher table feed compared to general machining.

Tool characteristics: Specially developed front teeth, very short cutting length and coating.

Machine requirements: Good stability, CNC, possibility for high table feed (v_f).

The big advantage of this technology is that it is very user friendly, easy, safe and quick to program in CAM. By using the so called Z-leveling strategy it is relatively easy to program complex forms without the necessity of having extensive experience in programming.

The application area is: From soft to hardened steel, titanium and stainless steel and it is very good as a pre operation before HSM is used.

It can also be applied in deep pocket machining.

Micro machining:

Is a machining strategy where extremely small tool diameters are used.

Tool characteristics: Diameter range \varnothing 0,1 to 2,0 mm, small cutting lengths, a wide range of OD reductions, high accuracy, coating.

Machine requirements: High spindle accuracy, high RPM, CNC, thermal stability against spindle growth.

Application area is: Production of cavities like slots, pockets, holes or engravings in many types of material.

Advanced roughing / Optirough:

Advanced roughing / Optirough (method/strategy): Well defined tool paths with constant arc of contact for reliable roughing of simple & complex shapes.

The large axial depths (a_p) & small radial depths (a_e) of cut combined with high feeds per tooth (f_z) and cutting speeds (V_c) results in high productivity.

Center cut FCEDC 1	Center cut FCEDC 2	No center cut FCEDC 2	2 teeth across center FCEDC 2	Uneven pitch FCEDC 2	Center cut FCEDC 3
No center cut FCEDC 3	3 teeth across center No center cut FCEDC 3	Uneven pitch FCEDC 3	Center cut FCEDC 4	2 teeth across center FCEDC 4	4 teeth across center FCEDC 4
No center cut FCEDC 4	No center cut FCEDC4	Uneven pitch 1 teeth across center FCEDC 4	Uneven pitch FCEDC 4	No center cut FCEDC 5	Uneven pitch FCEDC 5
No center cut FCEDC 6	2 teeth across center FCEDC 6	Uneven pitch FCEDC 6	No center cut FCEDC 7	No center cut FCEDC 8	
Cylindrical shank	Weldon	Safelock shank			
Sharp	Tapered sharp	Chamfer	Corner radius	Ball nose	Cutter 250°

RE	T-shape	Variable flute profile	Chip splitters	Roughing profile	Double core
Helix angle 0°	Helix angle Left 3°	Helix angle 3°	Helix angle 4°	Helix angle Left 10°	Helix angle 10°
Helix angle Left 15°	Helix angle 15°	Helix angle 17°	Helix angle 20°	Helix angle 25°	Helix angle 28°
Helix angle 30°	Helix angle 35°	Helix angle 37,5°	Helix angle 38°	Helix angle 40°	Helix angle 41°
Helix angle 42°	Helix angle 44°	Helix angle 45°	Helix angle 46°	Helix angle 48°	Helix angle 50°
Double helix 20° - 20°	Double helix 27° - 25°	Double helix 35° - 25°	Double helix 34° - 36°	Double helix 40° - 10°	Double helix 40° - 42°

Cutting rake 0°	Cutting rake 1°	Cutting rake -1°	Cutting rake 2°	Cutting rake 3°	Cutting rake 4°
Cutting rake 4-6°	Cutting rake 5°	Cutting rake 6°	Cutting rake 7°	Cutting rake 8°	Cutting rake 9°
Cutting rake 10°	Cutting rake 11°	Cutting rake 12°	Cutting rake -12°	Cutting rake 14°	Cutting rake 15°
Cutting rake 16°	Cutting rake 18°	Cutting rake 20°	Cutting rake -24°		
ICC straight	ICC and Y	ICC			
Radial	Radial/Ramping	Radial/Ramping/ Plunging	SIG	Advanced roughing	Back taper frontal teeth

<p>DIAMOND</p> <p>Diamond</p>	<p>DURA</p> <p>Dura</p>	<p>HEMI</p> <p>Hemi</p>	<p>HSS-Co</p> <p>HSS-Co</p>	<p>HXT</p> <p>HXT</p>	<p>M64</p> <p>M64</p>
<p>MEGA</p> <p>Mega</p>	<p>MEGA-64</p> <p>Mega-64</p>	<p>MEGA-64-T</p> <p>Mega-64-T</p>	<p>MEGA-T</p> <p>Mega-T</p>	<p>MT</p> <p>MT</p>	<p>NXT</p> <p>NXT</p>
<p>PCD</p> <p>PCD</p>	<p>SIRA</p> <p>SIRA</p>	<p>SIRON-A</p> <p>Siron-A</p>	<p>TRIBON</p> <p>Tribon</p>	<p>STAX</p> <p>Stax</p>	
 <p>Regrind possible</p>					























Name		JS512	JS513	JS514	JS553	JS554
Page(s)		30-34	35-40	41-45	46-55	56-74
Family name		JS ²	JS ²	JS ²	JS ²	JS ²
Type of mill						
Shank	Cylindrical	■	■	■	■	■
	Weldon	□	□	□	■	■
Number of Flutes		2	3	4	3	4
ICC						
Diameter range	Metric	1-25	1-25	1-25	2-25	3-25
	Inch				1/8-1	1/4-1
Length availability						
		2,3,4	2,3,4	2,3,4	2,3	2,3
Operation						
SMG						
P1-8		●	●	●	●	●
P11-12		○	○	○	●	●
M1-3		●	●	○	●	●
M4-5		○	○	○	●	●
K1-7		●	●	●	●	●
S1-3		○	○	○	●	●
S11-13		●	●	●	●	●
H5 H8 H11 H12 H21 H31		○	○	○	●	●
N1		○	○	○	●	●
N2-3		○	○	○	●	●
N11		○	○	○	●	●
TS1		○	○	○	●	●
TP1		○	○	○	●	●
GR		○	○	○	○	○

■ Stock standard □ Weldon available, delivery time is 3 days.
 ● Preferred choice ○ Alternative choice
 *JS554 3C also available. Can be applied in advanced roughing.























Name		JS564	JS565	JS520	JS522	JS532
Page(s)		75-77	78-80	81-83	85-86	87-90
Family name		JS ²	JS ²	JS ²	JS ²	JS ²
Type of mill						
Shank	Cylindrical	■	■	■	■	■
	Weldon	■	■	□		□
Number of Flutes		4	5	5-8	2	2
ICC						
Diameter range	Metric	3-20	3-20	4-25	6-32	1-20
	Inch				1/2-1 1/4	
Length availability		 2,3	 2,3	 2,3	 4	 1,2,3
Operation						
SMG						
P1-8		●	●	●	●	●
P11-12		○	○	○	●	○
M1-3		●	●	○	●	●
M4-5		●	●	○	●	●
K1-7		●	●	●	●	●
S1-3		●	●	○	○	○
S11-13		●	●	●	●	●
H5 H8 H11 H12 H21 H31		●	●	○		
N1		●	●	●	●	●
N2-3		●	●	●	●	●
N11		●	●	●	●	●
TS1				●	●	●
TP1				●	●	●
GR				○	○	○

■ Stock standard □ Weldon available, delivery time is 3 days.

● Preferred choice ○ Alternative choice

					
					
Name		JS533	JS534	JS506	JS509
Page(s)		91-93	94-96	97-99	100-102
Family name		JS ²	JS ²	JS ²	JS ²
Type of mill					
Shank	Cylindrical	■	■	■	■
	Weldon	■	■	■	■
Number of Flutes		3	4	3-4	3-4
ICC					
Diameter range	Metric	1-20	2-20	3-12	3-12
	Inch				
Length availability		 1,2	 1,2,3	 2	 2
Operation					
SMG					
P1-8		●	●	●	●
P11-12		○	○	○	○
M1-3		●	●	●	●
M4-5		●	●	●	●
K1-7		●	●	●	●
S1-3		○	○	○	○
S11-13		●	●	●	●
H5 H8 H11 H12 H21				●	●
N1		●	●	●	●
N2-3		●	●	●	●
N11		●	●	●	●
TS1		●	●	●	●
TP1		●	●	●	●
GR		○	○	○	○

■ Stock standard □ Weldon available, delivery time is 3 days.
● Preferred choice ○ Alternative choice

					
					
Name		JH910	JH930	JH970	JHF980
Page(s)		103-106	107	110-111, 168-169	112-115
Family name		HSM/TORNADO	HSM/TORNADO	HSM/TORNADO	HFM
Type of mill					
Shank	Cylindrical	■	■	■	■
	Weldon				
Number of Flutes		3	5-6, 8	2	2,3,4,5
ICC					
Diameter range	Metric	2-20	6-20	2-16	1-12
	Inch				
Length availability		 2,3,4	 2	 1,2,3	 1,2,3,4
Operation					
					
					
SMG					
P1-8		●	●	●	●
P11-12		○	○	○	○
M1-3		●		●	●
M4-5		●		●	●
K1-7		●	●	●	●
S1-3		●	●	●	●
S11-13		●	●	●	●
H3 H5 H7 H8 H11 H12 H21 H31			●		○
N1					
N2-3					
N11					
TS1					
TP1		●			
GR		●			

■ Stock standard □ Weldon available, delivery time is 3 days.

● Preferred choice ○ Alternative choice

Name		J29	J36	HK/HKM	TDM	V31
Page(s)		116-117	118-119	120-130		131-132
Family name		VHM	VHM	VHM	VHM	VHM
Type of mill						
Shank	Cylindrical	■	■	■	■	■
	Weldon					
Number of Flutes		1	3	2-4	2-4	4
ICC						
Diameter range	Metric	0,2-6	2-20	1-10	3-10	6-28
	Inch					
Length availability						
		2	2	2	2	2
Operation						
SMG						
P1-8		●	○	●	●	●
P11-12		●	●		●	
M1-3		●	○	●	●	●
M4-5		●	○	●	●	●
K1-7		●	○	●	●	●
S1-3		●	○	●	●	●
S11-13		●	○	●	●	●
H5 H8 H11 H12 H21				●		●
N1		●	○	●	●	●
N2-3		●	●	○	●	●
N11		●	●		●	
TS1		●	○	●	●	●
TP1		●	○	●	●	●
GR		●				●

■ Stock standard □ Weldon available, delivery time is 3 days.
 ● Preferred choice ○ Alternative choice

Name		JME542	JME562	JME564	JMB542	JMB562	JMB563
Page(s)		134	140-141	137- 139	144	147 - 148	151- 152
Family name		MINI	MINI	MINI	MINI	MINI	MINI
Type of mill							
Shank	Cylindrical	■	■	■	■	■	■
	Weldon						
Number of Flutes		2	2	4	2	2	2
DMM		4	6	6	4	6	6
Diameter range	Metric	0,2-3,0	0,5-3,0	0,5-3,0	0,2-3,0	0,5-3,0	1,0-3,0
	Inch						
Length availability		 1,3,4,5,6	 2,4,5,6,7	 2,4	 1,3,4,5,6	 2,4,5,6,7	 2,4
Operation							
SMG							
P1-8		●	●	●	●	●	●
P11-P12		●	●	●	●	●	●
M1-3		●	●	●	●	●	●
M4-5		●	●	●	●	●	●
K1-7							
S1-3		○	○	○	○	○	○
S11-13		●	●	●	●	●	●
H3 H5 H7 H8 H11 H12 H21 H31		○	○	○	○	○	○
N1		○	○	○	○	○	○
N2-3		○	○	○	○	○	○
N11		○	○	○	○	○	○
TS1							
TP1							
GR		○	○	○	○	○	○

■ Stock standard □ Weldon available, delivery time is 3 days.

● Preferred choice ○ Alternative choice

JS512 - General purpose - Universal - Square - 2 Flutes - Cylindrical - Chamfer



Tolerances:
 DMM= h5
 DC= e8
 Regrind possible if DC is ≥0.6

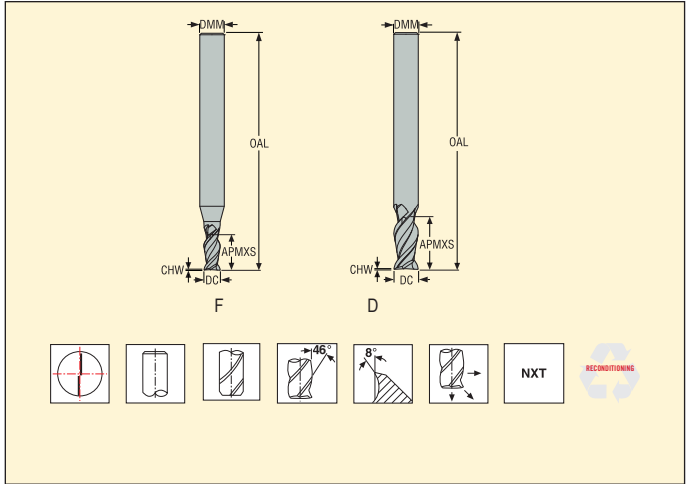

Ordering and Product No.	Designation	Length index	Tool shape	Dimensions in mm					PCEDC	Cylindrical
				DC	DMM	APMXS	OAL	CHW		
02927161	JS512010F2C.0Z2-NXT	2	F	1,0	3	2	38	0,01	2	■
02927163	JS512015F2C.0Z2-NXT	2	F	1,5	3	3	38	0,015	2	■
02927165	JS512021F2C.0Z2-NXT	2	F	2,0	3	4	38	0,02	2	■
02927164	JS512020F2C.0Z2-NXT	2	F	2,0	6	4	57	0,02	2	■
02927167	JS512030D2C.0Z2-NXT	2	D	3,0	3	6	38	0,03	2	■
02927166	JS512030F2C.0Z2-NXT	2	F	3,0	6	6	57	0,03	2	■
02927169	JS512040D2C.0Z2-NXT	2	D	4,0	4	8	50	0,04	2	■
02927168	JS512040F2C.0Z2-NXT	2	F	4,0	6	8	57	0,04	2	■
02927171	JS512050D2C.0Z2-NXT	2	D	5,0	5	10	50	0,05	2	■
02927170	JS512050F2C.0Z2-NXT	2	F	5,0	6	10	57	0,05	2	■
02927172	JS512060D2C.0Z2-NXT	2	D	6,0	6	12	57	0,06	2	■
02927173	JS512080D2C.0Z2-NXT	2	D	8,0	8	16	63	0,08	2	■
02927174	JS512100D2C.0Z2-NXT	2	D	10,0	10	20	72	0,1	2	■
02927175	JS512120D2C.0Z2-NXT	2	D	12,0	12	24	83	0,12	2	■
02927176	JS512160D2C.0Z2-NXT	2	D	16,0	16	30	92	0,16	2	■
02927191	JS512200D2C.0Z2-NXT	2	D	20,0	20	35	104	0,2	2	■
02927192	JS512250D2C.0Z2-NXT	2	D	25,0	25	40	125	0,25	2	■
02927193	JS512010F3C.0Z2-NXT	3	F	1,0	3	3	38	0,01	2	■
02927194	JS512015F3C.0Z2-NXT	3	F	1,5	3	6	38	0,015	2	■
02927177	JS512020F3C.0Z2-NXT	3	F	2,0	6	7	57	0,02	2	■
02927178	JS512030F3C.0Z2-NXT	3	F	3,0	6	10	57	0,03	2	■
02927179	JS512040F3C.0Z2-NXT	3	F	4,0	6	14	57	0,04	2	■
02927195	JS512050F3C.0Z2-NXT	3	F	5,0	6	18	57	0,05	2	■
02927180	JS512060D3C.0Z2-NXT	3	D	6,0	6	20	63	0,06	2	■
02927181	JS512080D3C.0Z2-NXT	3	D	8,0	8	28	80	0,08	2	■
02927182	JS512100D3C.0Z2-NXT	3	D	10,0	10	35	89	0,1	2	■
02927183	JS512120D3C.0Z2-NXT	3	D	12,0	12	42	100	0,12	2	■
02927196	JS512160D3C.0Z2-NXT	3	D	16,0	16	50	115	0,16	2	■
02927197	JS512200D3C.0Z2-NXT	3	D	20,0	20	60	125	0,2	2	■
02927184	JS512020F4C.0Z2-NXT	4	F	2,0	6	10	57	0,02	2	■
02927185	JS512030F4C.0Z2-NXT	4	F	3,0	6	15	57	0,03	2	■
02927186	JS512040F4C.0Z2-NXT	4	F	4,0	6	20	63	0,04	2	■
02927199	JS512050F4C.0Z2-NXT	4	F	5,0	6	25	63	0,05	2	■
02927188	JS512060D4C.0Z2-NXT	4	D	6,0	6	30	75	0,06	2	■
02927189	JS512080D4C.0Z2-NXT	4	D	8,0	8	40	100	0,08	2	■
02927190	JS512100D4C.0Z2-NXT	4	D	10,0	10	50	100	0,1	2	■

■ Stock standard. Subject to change refer to current price- and stock-list

JS512 - General purpose - Universal - Square - 2 Flutes - Weldon - Chamfer



Tolerances:
 DMM=h5
 DC=e8
 Regrind possible if DC is ≥0.6

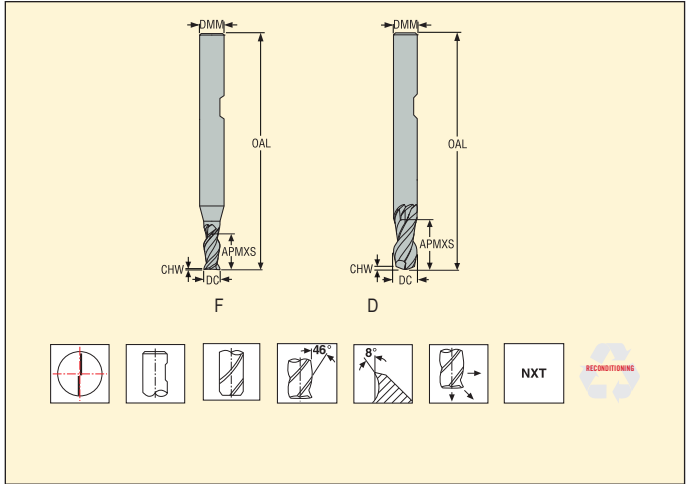

Ordering and Product No.	Designation	Length index	Tool shape	Dimensions in mm					PCEDC	Weldon
				DC	DMM	APMXS	OAL	CHW		
02927267	JS512020F2C.3Z2-NXT	2	F	2,0	6	4	57	0,02	2	<input type="checkbox"/>
02927268	JS512030F2C.3Z2-NXT	2	F	3,0	6	6	57	0,03	2	<input type="checkbox"/>
02927269	JS512040F2C.3Z2-NXT	2	F	4,0	6	8	57	0,04	2	<input type="checkbox"/>
02927270	JS512050F2C.3Z2-NXT	2	F	5,0	6	10	57	0,05	2	<input type="checkbox"/>
02927271	JS512060D2C.3Z2-NXT	2	D	6,0	6	12	57	0,06	2	<input type="checkbox"/>
02927272	JS512080D2C.3Z2-NXT	2	D	8,0	8	16	63	0,08	2	<input type="checkbox"/>
02927273	JS512100D2C.3Z2-NXT	2	D	10,0	10	20	72	0,1	2	<input type="checkbox"/>
02927274	JS512120D2C.3Z2-NXT	2	D	12,0	12	24	83	0,12	2	<input type="checkbox"/>
02927275	JS512160D2C.3Z2-NXT	2	D	16,0	16	30	92	0,16	2	<input type="checkbox"/>
02927276	JS512200D2C.3Z2-NXT	2	D	20,0	20	35	104	0,2	2	<input type="checkbox"/>
02927277	JS512250D2C.3Z2-NXT	2	D	25,0	25	40	125	0,25	2	<input type="checkbox"/>
02927278	JS512020F3C.3Z2-NXT	3	F	2,0	6	7	57	0,02	2	<input type="checkbox"/>
02927279	JS512030F3C.3Z2-NXT	3	F	3,0	6	10	57	0,03	2	<input type="checkbox"/>
02927280	JS512040F3C.3Z2-NXT	3	F	4,0	6	14	57	0,04	2	<input type="checkbox"/>
02927281	JS512050F3C.3Z2-NXT	3	F	5,0	6	18	57	0,05	2	<input type="checkbox"/>
02927282	JS512060D3C.3Z2-NXT	3	D	6,0	6	20	63	0,06	2	<input type="checkbox"/>
02927283	JS512080D3C.3Z2-NXT	3	D	8,0	8	28	80	0,08	2	<input type="checkbox"/>
02927284	JS512100D3C.3Z2-NXT	3	D	10,0	10	35	89	0,1	2	<input type="checkbox"/>
02927285	JS512120D3C.3Z2-NXT	3	D	12,0	12	42	100	0,12	2	<input type="checkbox"/>
02927286	JS512160D3C.3Z2-NXT	3	D	16,0	16	50	115	0,16	2	<input type="checkbox"/>
02927287	JS512200D3C.3Z2-NXT	3	D	20,0	20	60	125	0,2	2	<input type="checkbox"/>
02927288	JS512250D3C.3Z2-NXT	3	D	25,0	25	70	150	0,25	2	<input type="checkbox"/>
02927289	JS512020F4C.3Z2-NXT	4	F	2,0	6	10	57	0,02	2	<input type="checkbox"/>
02927290	JS512030F4C.3Z2-NXT	4	F	3,0	6	15	57	0,03	2	<input type="checkbox"/>
02927291	JS512040F4C.3Z2-NXT	4	F	4,0	6	20	63	0,04	2	<input type="checkbox"/>
02927292	JS512050F4C.3Z2-NXT	4	F	5,0	6	25	63	0,05	2	<input type="checkbox"/>
02927293	JS512060D4C.3Z2-NXT	4	D	6,0	6	30	75	0,06	2	<input type="checkbox"/>
02927294	JS512080D4C.3Z2-NXT	4	D	8,0	8	40	100	0,08	2	<input type="checkbox"/>
02927295	JS512100D4C.3Z2-NXT	4	D	10,0	10	50	100	0,1	2	<input type="checkbox"/>
02927296	JS512120D4C.3Z2-NXT	4	D	12,0	12	60	125	0,12	2	<input type="checkbox"/>
02927297	JS512160D4C.3Z2-NXT	4	D	16,0	16	70	130	0,16	2	<input type="checkbox"/>
02927298	JS512200D4C.3Z2-NXT	4	D	20,0	20	80	150	0,2	2	<input type="checkbox"/>
02927299	JS512250D4C.3Z2-NXT	4	D	25,0	25	90	165	0,25	2	<input type="checkbox"/>

Weldon available, delivery time is 3 days.

Cutting data – JS512 Slot milling

SMG		a _p /DC	f _z														v _c
			1	2	3	4	5	6	8	10	12	16	20	25			
P1	E	1.0	0,0050	0,010	0,015	0,020	0,026	0,030	0,040	0,050	0,060	0,080	0,10	0,13	175 (150 – 205)		
P2	E	1.0	0,0050	0,010	0,015	0,020	0,026	0,030	0,040	0,050	0,060	0,080	0,10	0,13	150 (125 – 170)		
P3	E	1.0	0,0050	0,010	0,015	0,020	0,026	0,030	0,040	0,050	0,060	0,080	0,10	0,13	150 (125 – 170)		
P4	E	1.0	0,0050	0,010	0,015	0,020	0,026	0,030	0,040	0,050	0,060	0,080	0,10	0,13	130 (110 – 150)		
P5	E	1.0	0,0050	0,010	0,015	0,020	0,026	0,030	0,040	0,050	0,060	0,080	0,10	0,13	120 (100 – 140)		
P6	E	1.0	0,0050	0,010	0,015	0,020	0,026	0,030	0,040	0,050	0,060	0,080	0,10	0,13	135 (115 – 160)		
P7	E	1.0	0,0050	0,010	0,015	0,020	0,026	0,030	0,040	0,050	0,060	0,080	0,10	0,13	130 (105 – 150)		
P8	E	1.0	0,0050	0,010	0,015	0,020	0,026	0,030	0,040	0,050	0,060	0,080	0,10	0,13	120 (100 – 140)		
P11	E	1.0	0,0050	0,010	0,015	0,020	0,026	0,030	0,040	0,050	0,060	0,080	0,10	0,13	125 (105 – 145)		
P12	E	0.80	0,0042	0,0080	0,012	0,016	0,020	0,024	0,032	0,042	0,050	0,065	0,075	0,085	75 (65 – 90)		
M1	E	0.80	0,0050	0,010	0,015	0,020	0,026	0,030	0,040	0,050	0,060	0,080	0,10	0,13	100 (85 – 110)		
M2	E	0.80	0,0050	0,010	0,015	0,020	0,026	0,030	0,040	0,050	0,060	0,080	0,10	0,13	80 (70 – 90)		
M3	E	0.60	0,0050	0,010	0,015	0,020	0,026	0,030	0,040	0,050	0,060	0,080	0,10	0,13	50 (40 – 60)		
M4	E	0.45	0,0050	0,010	0,015	0,020	0,026	0,030	0,040	0,050	0,060	0,080	0,10	0,13	38 (30 – 45)		
M5	E	0.45	0,0050	0,010	0,015	0,020	0,026	0,030	0,040	0,050	0,060	0,080	0,10	0,13	31 (25 – 38)		
K1	E	1.0	0,0050	0,010	0,015	0,020	0,026	0,030	0,040	0,050	0,060	0,080	0,10	0,13	150 (130 – 170)		
K2	E	1.0	0,0050	0,010	0,015	0,020	0,026	0,030	0,040	0,050	0,060	0,080	0,10	0,13	130 (115 – 150)		
K3	E	1.0	0,0050	0,010	0,015	0,020	0,026	0,030	0,040	0,050	0,060	0,080	0,10	0,13	110 (95 – 125)		
K4	E	1.0	0,0050	0,010	0,015	0,020	0,026	0,030	0,040	0,050	0,060	0,080	0,10	0,13	105 (90 – 120)		
K5	E	0.80	0,0050	0,010	0,015	0,020	0,026	0,030	0,040	0,050	0,060	0,080	0,10	0,13	130 (110 – 150)		
K6	E	0.80	0,0050	0,010	0,015	0,020	0,026	0,030	0,040	0,050	0,060	0,080	0,10	0,13	140 (120 – 160)		
K7	E	0.80	0,0050	0,010	0,015	0,020	0,026	0,030	0,040	0,050	0,060	0,080	0,10	0,13	120 (105 – 140)		
N1	E	0.40	0,0060	0,012	0,018	0,024	0,030	0,036	0,048	0,060	0,070	0,095	0,12	0,15	405 (300 – 500)		
N2	E	0.40	0,0060	0,012	0,018	0,024	0,030	0,036	0,048	0,060	0,070	0,095	0,12	0,15	405 (300 – 500)		
N3	E	0.40	0,0060	0,012	0,018	0,024	0,030	0,036	0,048	0,060	0,070	0,095	0,12	0,15	270 (200 – 335)		
N11	E	1.0	0,0060	0,012	0,018	0,024	0,030	0,036	0,048	0,060	0,070	0,095	0,12	0,15	300 (200 – 400)		
S1	E	0.20	0,0020	0,0040	0,0060	0,0080	0,010	0,012	0,016	0,020	0,024	0,032	0,040	0,050	43 (32 – 55)		
S2	E	0.20	0,0020	0,0040	0,0060	0,0080	0,010	0,012	0,016	0,020	0,024	0,032	0,040	0,050	35 (26 – 44)		
S3	E	0.20	0,0020	0,0040	0,0060	0,0080	0,010	0,012	0,016	0,020	0,024	0,032	0,040	0,050	27 (16 – 38)		
S11	E	0.60	0,0040	0,0080	0,012	0,016	0,020	0,024	0,032	0,040	0,050	0,065	0,080	0,10	90 (65 – 105)		
S12	E	0.60	0,0040	0,0080	0,012	0,016	0,020	0,024	0,032	0,040	0,050	0,065	0,080	0,10	70 (50 – 80)		
S13	E	0.50	0,0040	0,0080	0,012	0,016	0,020	0,024	0,032	0,040	0,050	0,065	0,080	0,10	50 (38 – 65)		
H5	M/A/D	0.20	0,0020	0,0040	0,0060	0,0080	0,010	0,012	0,016	0,020	0,024	0,032	0,040	0,050	50 (40 – 60)		
H8	M/A/D	0.17	0,0019	0,0038	0,0055	0,0075	0,0095	0,011	0,015	0,019	0,022	0,030	0,038	0,046	50 (41 – 60)		
H11	M/A/D	0.20	0,0020	0,0040	0,0060	0,0080	0,010	0,012	0,016	0,020	0,024	0,032	0,040	0,050	65 (50 – 75)		
H12	M/A/D	0.17	0,0019	0,0038	0,0055	0,0075	0,0095	0,011	0,015	0,019	0,022	0,030	0,038	0,046	60 (47 – 70)		
H21	M/A/D	0.17	0,0019	0,0038	0,0055	0,0075	0,0095	0,011	0,015	0,019	0,022	0,030	0,038	0,046	50 (41 – 60)		
TS1	A	1.0	0,0080	0,016	0,024	0,032	0,040	0,048	0,065	0,080	0,095	0,13	0,16	0,20	500 (400 – 600)		
TP1	A	1.0	0,0080	0,016	0,024	0,032	0,040	0,048	0,065	0,080	0,095	0,13	0,16	0,20	500 (400 – 600)		
GR1	D/A	1.0	0,0080	0,016	0,024	0,032	0,040	0,048	0,065	0,080	0,095	0,13	0,16	0,20	485 (390 – 580)		

For cutting data recalculations, see page 411-418.

SMG = Seco material group

Coolant = A=air D=dry E=emulsion M=mist spray

v_c = m/min

f_z = mm

a_p (mm)/DC (mm)= factor

All cutting data are target values

Cutting data – JS512 Side milling

SMG		a _p /DC	a _p /DC	f _z													v _c
				1	2	3	4	5	6	8	10	12	16	20	25		
P1	M/A/D/E	0.40	1.2	0,0090	0,018	0,026	0,036	0,044	0,055	0,070	0,090	0,10	0,13	0,15	0,17	195 (165 – 225)	
P2	M/A/D/E	0.40	1.2	0,0090	0,018	0,026	0,036	0,044	0,055	0,070	0,090	0,11	0,13	0,15	0,17	165 (135 – 185)	
P3	M/A/D/E	0.40	1.2	0,0085	0,017	0,026	0,034	0,042	0,050	0,070	0,085	0,10	0,12	0,14	0,16	165 (140 – 190)	
P4	M/A/D/E	0.40	1.2	0,0085	0,017	0,024	0,034	0,042	0,050	0,065	0,085	0,10	0,12	0,14	0,16	145 (125 – 165)	
P5	M/A/D/E	0.40	1.2	0,0080	0,016	0,024	0,032	0,040	0,050	0,065	0,080	0,095	0,12	0,14	0,16	135 (115 – 160)	
P6	M/A/D/E	0.40	1.2	0,0080	0,016	0,024	0,032	0,040	0,048	0,065	0,080	0,095	0,12	0,14	0,15	150 (125 – 180)	
P7	M/A/D/E	0.40	1.2	0,0080	0,016	0,024	0,032	0,040	0,048	0,065	0,080	0,095	0,12	0,14	0,15	145 (120 – 170)	
P8	M/A/D/E	0.40	1.2	0,0085	0,017	0,026	0,034	0,042	0,050	0,070	0,085	0,10	0,12	0,14	0,16	135 (110 – 155)	
P11	M/A/D/E	0.40	1.2	0,0080	0,016	0,024	0,032	0,040	0,048	0,065	0,080	0,095	0,12	0,14	0,15	140 (115 – 165)	
P12	M/A/D/E	0.40	1.0	0,0046	0,0090	0,014	0,018	0,022	0,028	0,036	0,046	0,055	0,065	0,075	0,085	95 (80 – 110)	
M1	E/M/A	0.40	1.0	0,0080	0,016	0,024	0,032	0,040	0,050	0,065	0,080	0,095	0,12	0,14	0,16	110 (100 – 125)	
M2	E/M/A	0.40	1.0	0,0075	0,015	0,022	0,030	0,038	0,044	0,060	0,075	0,090	0,11	0,13	0,14	90 (80 – 105)	
M3	E/M/A	0.40	1.0	0,0080	0,016	0,024	0,032	0,040	0,050	0,065	0,080	0,095	0,12	0,14	0,16	55 (45 – 70)	
M4	E/M/A	0.40	0.70	0,0070	0,014	0,022	0,028	0,036	0,042	0,055	0,070	0,085	0,11	0,12	0,14	44 (35 – 55)	
M5	E/M/A	0.40	0.70	0,0070	0,014	0,022	0,028	0,036	0,042	0,055	0,070	0,085	0,11	0,12	0,14	37 (29 – 44)	
K1	A/D/M/E	0.40	1.2	0,0080	0,016	0,024	0,032	0,040	0,048	0,065	0,080	0,095	0,12	0,13	0,15	170 (145 – 190)	
K2	A/D/M/E	0.40	1.2	0,0070	0,014	0,022	0,028	0,036	0,044	0,060	0,070	0,085	0,11	0,12	0,14	150 (130 – 170)	
K3	A/D/M/E	0.40	1.2	0,0070	0,014	0,022	0,028	0,036	0,044	0,060	0,070	0,085	0,11	0,12	0,14	130 (110 – 145)	
K4	A/D/M/E	0.40	1.2	0,0070	0,014	0,022	0,028	0,036	0,044	0,060	0,070	0,085	0,11	0,12	0,14	125 (105 – 140)	
K5	A/D/M/E	0.40	1.2	0,0080	0,016	0,024	0,032	0,040	0,048	0,065	0,080	0,095	0,12	0,13	0,15	145 (125 – 170)	
K6	A/D/M/E	0.40	1.2	0,0090	0,018	0,026	0,036	0,044	0,055	0,070	0,090	0,10	0,13	0,15	0,17	155 (130 – 175)	
K7	A/D/M/E	0.40	1.2	0,0080	0,016	0,024	0,032	0,040	0,048	0,065	0,080	0,095	0,12	0,13	0,15	135 (115 – 155)	
N1	E/M/A	0.30	1.0	0,012	0,024	0,036	0,048	0,060	0,070	0,095	0,12	0,14	0,18	0,20	0,24	455 (340 – 570)	
N2	E/M/A	0.30	1.0	0,012	0,024	0,036	0,048	0,060	0,070	0,095	0,12	0,14	0,18	0,20	0,24	455 (340 – 570)	
N3	E/M/A	0.30	1.0	0,012	0,024	0,036	0,048	0,060	0,070	0,095	0,12	0,14	0,18	0,20	0,24	305 (230 – 380)	
S1	E	0.20	1.0	0,0044	0,0085	0,013	0,017	0,022	0,026	0,034	0,044	0,050	0,065	0,075	0,085	55 (41 – 70)	
S2	E	0.20	1.0	0,0044	0,0085	0,013	0,017	0,022	0,026	0,034	0,044	0,050	0,065	0,075	0,085	44 (33 – 55)	
S3	E	0.20	1.0	0,0040	0,0080	0,012	0,016	0,020	0,024	0,032	0,040	0,048	0,060	0,070	0,075	34 (21 – 48)	
S11	E	0.30	1.0	0,0075	0,015	0,022	0,030	0,038	0,046	0,060	0,075	0,090	0,11	0,13	0,15	105 (75 – 125)	
S12	E	0.30	1.0	0,0075	0,015	0,022	0,030	0,038	0,046	0,060	0,075	0,090	0,11	0,13	0,15	80 (60 – 95)	
S13	E	0.30	0.90	0,0065	0,013	0,020	0,026	0,034	0,040	0,055	0,065	0,080	0,10	0,11	0,13	65 (46 – 75)	
H5	M/A/D	0.030	0.50	0,012	0,024	0,036	0,048	0,060	0,070	0,095	0,12	0,14	0,19	0,24	0,30	80 (65 – 95)	
H8	M/A/D	0.030	0.50	0,011	0,022	0,034	0,044	0,055	0,065	0,090	0,11	0,13	0,18	0,22	0,28	80 (65 – 95)	
H21	M/A/D	0.030	0.50	0,011	0,022	0,034	0,044	0,055	0,065	0,090	0,11	0,13	0,18	0,22	0,28	80 (65 – 95)	
H31	M/A/D	0.030	0.50	0,0095	0,019	0,028	0,038	0,048	0,055	0,075	0,095	0,11	0,15	0,19	0,24	65 (50 – 75)	
TS1	A/D	0.40	1.4	0,013	0,026	0,038	0,050	0,065	0,080	0,10	0,13	0,15	0,19	0,22	0,24	550 (445 – 660)	
TP1	A/D	0.40	1.4	0,013	0,026	0,038	0,050	0,065	0,080	0,10	0,13	0,15	0,19	0,22	0,24	550 (445 – 660)	
GR1	A/D	0.40	1.4	0,013	0,026	0,038	0,050	0,065	0,080	0,10	0,13	0,15	0,19	0,22	0,24	540 (430 – 640)	

For cutting data recalculations, see page 411-418.

SMG = Seco material group

Coolant = A=air D=dry E=emulsion M=mist spray

v_c = m/min

f_z = mm

a_p (mm)/DC (mm)= factor

a_e (mm)/DC (mm)= factor

All cutting data are target values

JS513 – General purpose – Universal – Square – 3 Flutes – Cylindrical – Chamfer



Tolerances:
 DMM=h5
 DC=e8
 Regrind possible if DC is ≥Ø6

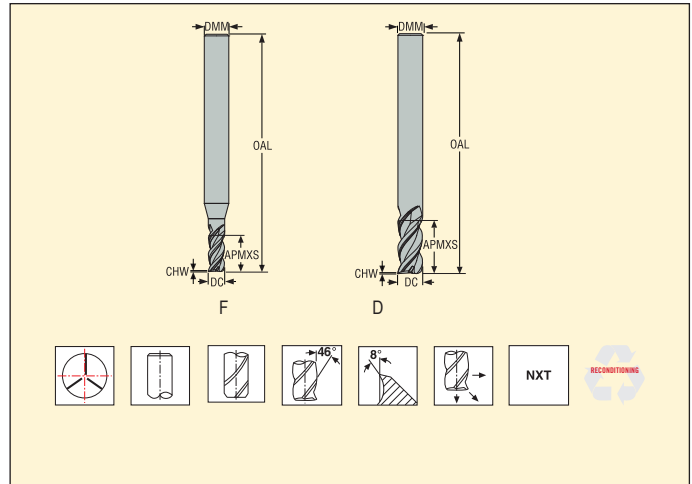

Ordering and Product No.	Designation	Length index	Tool shape	Dimensions in mm					PCEDC	Cylindrical
				DC	DMM	APMXS	OAL	CHW		
02927301	JS513010F2C.0Z3-NXT	2	F	1,0	3	2	38	0,01	3	■
02928157	JS513015F2C.0Z3-NXT	2	F	1,5	3	3	38	0,015	3	■
02927304	JS513021F2C.0Z3-NXT	2	F	2,0	3	4	38	0,02	3	■
02927303	JS513020F2C.0Z3-NXT	2	F	2,0	6	4	57	0,02	3	■
02927305	JS513025F2C.0Z3-NXT	2	F	2,5	6	5	57	0,025	3	■
02927306	JS513030F2C.0Z3-NXT	2	F	3,0	6	6	57	0,03	3	■
02927307	JS513030D2C.0Z3-NXT	2	D	3,0	3	6	38	0,03	3	■
02927308	JS513040F2C.0Z3-NXT	2	F	4,0	6	8	57	0,04	3	■
02927310	JS513040D2C.0Z3-NXT	2	D	4,0	4	8	50	0,04	3	■
02927311	JS513050F2C.0Z3-NXT	2	F	5,0	6	10	57	0,05	3	■
02927312	JS513050D2C.0Z3-NXT	2	D	5,0	5	10	50	0,05	3	■
02927313	JS513060D2C.0Z3-NXT	2	D	6,0	6	12	57	0,06	3	■
02927314	JS513080D2C.0Z3-NXT	2	D	8,0	8	16	63	0,08	3	■
02927315	JS513100D2C.0Z3-NXT	2	D	10,0	10	20	72	0,1	3	■
02927316	JS513120D2C.0Z3-NXT	2	D	12,0	12	24	83	0,12	3	■
02927317	JS513140D2C.0Z3-NXT	2	D	14,0	14	28	83	0,14	3	■
02927318	JS513160D2C.0Z3-NXT	2	D	16,0	16	30	92	0,16	3	■
02927319	JS513180D2C.0Z3-NXT	2	D	18,0	18	35	100	0,18	3	■
02927341	JS513200D2C.0Z3-NXT	2	D	20,0	20	35	104	0,2	3	■
02927342	JS513250D2C.0Z3-NXT	2	D	25,0	25	40	125	0,25	3	■
02927302	JS513010F3C.0Z3-NXT	3	F	1,0	3	3	38	0,01	3	■
02927320	JS513015F3C.0Z3-NXT	3	F	1,5	3	6	38	0,015	3	■
02927321	JS513020F3C.0Z3-NXT	3	F	2,0	6	7	57	0,02	3	■
02927343	JS513025F3C.0Z3-NXT	3	F	2,5	6	9	57	0,025	3	■
02927322	JS513030F3C.0Z3-NXT	3	F	3,0	6	10	57	0,03	3	■
02927323	JS513040F3C.0Z3-NXT	3	F	4,0	6	14	57	0,04	3	■
02927324	JS513050F3C.0Z3-NXT	3	F	5,0	6	18	57	0,05	3	■
02927325	JS513060D3C.0Z3-NXT	3	D	6,0	6	20	63	0,06	3	■
02927326	JS513080D3C.0Z3-NXT	3	D	8,0	8	28	80	0,08	3	■
02927327	JS513100D3C.0Z3-NXT	3	D	10,0	10	35	89	0,1	3	■
02927328	JS513120D3C.0Z3-NXT	3	D	12,0	12	42	100	0,12	3	■
02927329	JS513140D3C.0Z3-NXT	3	D	14,0	14	50	120	0,14	3	■
02927330	JS513160D3C.0Z3-NXT	3	D	16,0	16	50	115	0,16	3	■
02927331	JS513200D3C.0Z3-NXT	3	D	20,0	20	60	125	0,2	3	■
02927344	JS513250D3C.0Z3-NXT	3	D	25,0	25	70	150	0,25	3	■

■ Stock standard. Subject to change refer to current price- and stock-list

JS513 – General purpose – Universal – Square – 3 Flutes – Weldon – Chamfer



Tolerances:

DMM=h5

DC=e8

Regrind possible if DC is ≥Ø6

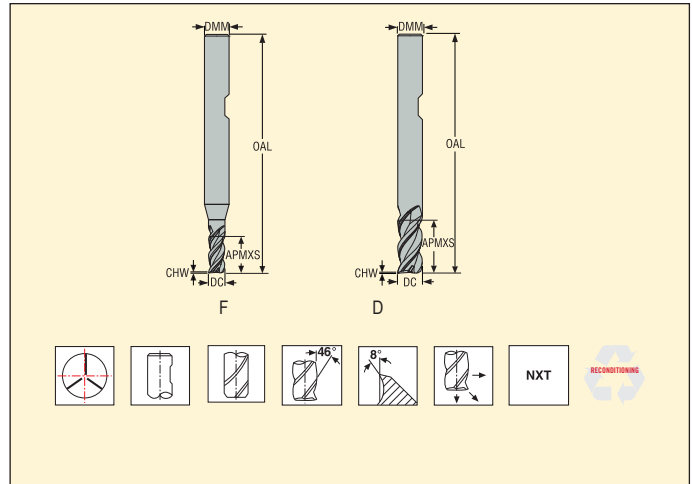

Ordering and Product No.	Designation	Length index	Tool shape	Dimensions in mm					PCEDC	Weldon
				DC	DMM	APMXS	OAL	CHW		
02927355	JS513020F2C.3Z3-NXT	2	F	2,0	6	4	57	0,02	3	<input type="checkbox"/>
02927356	JS513025F2C.3Z3-NXT	2	F	2,5	6	5	57	0,025	3	<input type="checkbox"/>
02927357	JS513030F2C.3Z3-NXT	2	F	3,0	6	6	57	0,03	3	<input type="checkbox"/>
02927358	JS513040F2C.3Z3-NXT	2	F	4,0	6	8	57	0,04	3	<input type="checkbox"/>
02927359	JS513050F2C.3Z3-NXT	2	F	5,0	6	10	57	0,05	3	<input type="checkbox"/>
02927360	JS513060D2C.3Z3-NXT	2	D	6,0	6	12	57	0,06	3	<input checked="" type="checkbox"/>
02927361	JS513080D2C.3Z3-NXT	2	D	8,0	8	16	63	0,08	3	<input checked="" type="checkbox"/>
02927362	JS513100D2C.3Z3-NXT	2	D	10,0	10	20	72	0,1	3	<input checked="" type="checkbox"/>
02927363	JS513120D2C.3Z3-NXT	2	D	12,0	12	24	83	0,12	3	<input checked="" type="checkbox"/>
02927364	JS513140D2C.3Z3-NXT	2	D	14,0	14	28	83	0,14	3	<input type="checkbox"/>
02927365	JS513160D2C.3Z3-NXT	2	D	16,0	16	30	92	0,16	3	<input type="checkbox"/>
02927366	JS513180D2C.3Z3-NXT	2	D	18,0	18	35	100	0,18	3	<input type="checkbox"/>
02927367	JS513200D2C.3Z3-NXT	2	D	20,0	20	35	104	0,2	3	<input type="checkbox"/>
02927368	JS513250D2C.3Z3-NXT	2	D	25,0	25	40	125	0,25	3	<input type="checkbox"/>
02927369	JS513020F3C.3Z3-NXT	3	F	2,0	6	7	57	0,02	3	<input type="checkbox"/>
02927370	JS513025F3C.3Z3-NXT	3	F	2,5	6	9	57	0,025	3	<input type="checkbox"/>
02927371	JS513030F3C.3Z3-NXT	3	F	3,0	6	10	57	0,03	3	<input type="checkbox"/>
02927372	JS513040F3C.3Z3-NXT	3	F	4,0	6	14	57	0,04	3	<input checked="" type="checkbox"/>
02927373	JS513050F3C.3Z3-NXT	3	F	5,0	6	18	57	0,05	3	<input type="checkbox"/>
02927374	JS513060D3C.3Z3-NXT	3	D	6,0	6	20	63	0,06	3	<input checked="" type="checkbox"/>
02927375	JS513080D3C.3Z3-NXT	3	D	8,0	8	28	80	0,08	3	<input type="checkbox"/>
02927376	JS513100D3C.3Z3-NXT	3	D	10,0	10	35	89	0,1	3	<input type="checkbox"/>
02927377	JS513120D3C.3Z3-NXT	3	D	12,0	12	42	100	0,12	3	<input type="checkbox"/>
02927378	JS513140D3C.3Z3-NXT	3	D	14,0	14	50	120	0,14	3	<input type="checkbox"/>
02927379	JS513160D3C.3Z3-NXT	3	D	16,0	16	50	115	0,16	3	<input type="checkbox"/>
02927380	JS513200D3C.3Z3-NXT	3	D	20,0	20	60	125	0,2	3	<input type="checkbox"/>
02927381	JS513250D3C.3Z3-NXT	3	D	25,0	25	70	150	0,25	3	<input type="checkbox"/>
02927382	JS513020F4C.3Z3-NXT	4	F	2,0	6	10	57	0,02	3	<input type="checkbox"/>
02927383	JS513025F4C.3Z3-NXT	4	F	2,5	6	13	57	0,025	3	<input type="checkbox"/>
02927384	JS513030F4C.3Z3-NXT	4	F	3,0	6	15	57	0,03	3	<input type="checkbox"/>
02927385	JS513040F4C.3Z3-NXT	4	F	4,0	6	20	63	0,04	3	<input type="checkbox"/>
02927386	JS513050F4C.3Z3-NXT	4	F	5,0	6	25	63	0,05	3	<input type="checkbox"/>
02927387	JS513060D4C.3Z3-NXT	4	D	6,0	6	30	80	0,06	3	<input type="checkbox"/>
02927388	JS513080D4C.3Z3-NXT	4	D	8,0	8	40	100	0,08	3	<input type="checkbox"/>
02927389	JS513100D4C.3Z3-NXT	4	D	10,0	10	50	100	0,1	3	<input type="checkbox"/>
02927390	JS513120D4C.3Z3-NXT	4	D	12,0	12	60	125	0,12	3	<input type="checkbox"/>
02927391	JS513140D4C.3Z3-NXT	4	D	14,0	14	65	140	0,14	3	<input type="checkbox"/>

■ Stock standard. Subject to change refer to current price- and stock-list □ Weldon available, delivery time is 3 days.

Cutting data – JS513 Side milling

SMG		a _e /DC	a _p /DC	f _z														v _c
				1	2	3	4	5	6	8	10	12	14	16	18	20	25	
P1	M/A/D/E	0,40	1,0	0,0065	0,013	0,020	0,026	0,034	0,040	0,055	0,065	0,080	0,090	0,095	0,11	0,11	0,13	200 (170 – 230)
P2	M/A/D/E	0,40	1,0	0,0065	0,013	0,020	0,026	0,034	0,040	0,055	0,065	0,080	0,090	0,10	0,11	0,11	0,13	195 (165 – 225)
P3	M/A/D/E	0,40	1,0	0,0065	0,013	0,019	0,026	0,032	0,038	0,050	0,065	0,075	0,085	0,095	0,10	0,11	0,12	170 (140 – 195)
P4	M/A/D/E	0,40	1,0	0,0060	0,012	0,019	0,024	0,032	0,038	0,050	0,060	0,075	0,085	0,090	0,10	0,11	0,12	150 (125 – 175)
P5	M/A/D/E	0,40	1,0	0,0060	0,012	0,018	0,024	0,030	0,036	0,048	0,060	0,070	0,080	0,090	0,095	0,10	0,12	140 (115 – 160)
P6	M/A/D/E	0,40	1,0	0,0060	0,012	0,018	0,024	0,030	0,036	0,048	0,060	0,070	0,080	0,090	0,095	0,10	0,12	155 (130 – 180)
P7	M/A/D/E	0,40	1,0	0,0060	0,012	0,018	0,024	0,030	0,036	0,048	0,060	0,070	0,080	0,090	0,095	0,10	0,12	145 (125 – 170)
P8	M/A/D/E	0,40	1,0	0,0065	0,013	0,019	0,026	0,032	0,038	0,050	0,065	0,075	0,085	0,095	0,10	0,11	0,12	135 (115 – 160)
P11	M/A/D/E	0,40	1,0	0,0060	0,012	0,018	0,024	0,030	0,036	0,048	0,060	0,070	0,080	0,090	0,095	0,10	0,12	145 (120 – 165)
P12	M/A/D/E	0,40	0,80	0,0034	0,0070	0,010	0,014	0,017	0,020	0,028	0,034	0,040	0,046	0,050	0,055	0,060	0,065	95 (80 – 110)
M1	E/M/A	0,40	1,0	0,0050	0,010	0,015	0,020	0,026	0,030	0,040	0,050	0,060	0,070	0,075	0,080	0,085	0,10	115 (100 – 125)
M2	E/M/A	0,40	1,0	0,0046	0,0095	0,014	0,019	0,024	0,028	0,038	0,046	0,055	0,060	0,070	0,075	0,080	0,090	95 (80 – 105)
M3	E/M/A	0,40	1,0	0,0050	0,010	0,015	0,020	0,026	0,030	0,040	0,050	0,060	0,070	0,075	0,080	0,085	0,10	55 (46 – 70)
M4	E/M/A	0,40	0,70	0,0044	0,0090	0,013	0,018	0,022	0,026	0,036	0,044	0,055	0,060	0,065	0,070	0,075	0,085	44 (35 – 55)
M5	E/M/A	0,40	0,70	0,0044	0,0090	0,013	0,018	0,022	0,026	0,036	0,044	0,055	0,060	0,065	0,070	0,075	0,085	37 (29 – 44)
K1	A/D/M/E	0,40	1,0	0,0050	0,010	0,015	0,020	0,026	0,030	0,040	0,050	0,060	0,070	0,075	0,080	0,085	0,10	170 (150 – 195)
K2	A/D/M/E	0,40	1,0	0,0046	0,0095	0,014	0,019	0,024	0,028	0,038	0,046	0,055	0,060	0,070	0,075	0,080	0,090	150 (130 – 170)
K3	A/D/M/E	0,40	1,0	0,0046	0,0095	0,014	0,019	0,024	0,028	0,038	0,046	0,055	0,060	0,070	0,075	0,080	0,090	130 (110 – 145)
K4	A/D/M/E	0,40	1,0	0,0046	0,0095	0,014	0,019	0,024	0,028	0,038	0,046	0,055	0,060	0,070	0,075	0,080	0,090	120 (105 – 140)
K5	A/D/M/E	0,40	1,0	0,0050	0,010	0,015	0,020	0,026	0,030	0,040	0,050	0,060	0,070	0,075	0,080	0,085	0,10	150 (125 – 170)
K6	A/D/M/E	0,40	1,0	0,0055	0,011	0,017	0,022	0,028	0,034	0,046	0,055	0,065	0,075	0,085	0,090	0,095	0,11	215 (180 – 250)
K7	A/D/M/E	0,40	1,0	0,0050	0,010	0,015	0,020	0,026	0,030	0,040	0,050	0,060	0,070	0,075	0,080	0,085	0,10	190 (160 – 220)
N1	E/M/A	0,30	1,0	0,0050	0,010	0,015	0,020	0,024	0,030	0,040	0,050	0,060	0,065	0,075	0,080	0,085	0,095	400 (300 – 500)
N2	E/M/A	0,30	1,0	0,0050	0,010	0,015	0,020	0,024	0,030	0,040	0,050	0,060	0,065	0,075	0,080	0,085	0,095	255 (195 – 320)
N3	E/M/A	0,30	1,0	0,0050	0,010	0,015	0,020	0,024	0,030	0,040	0,050	0,060	0,065	0,075	0,080	0,085	0,095	170 (130 – 215)
N11	E/M/A	0,40	1,0	0,0090	0,018	0,028	0,036	0,046	0,055	0,075	0,090	0,11	0,12	0,14	0,15	0,16	0,18	345 (230 – 455)
S1	E	0,20	1,0	0,0075	0,015	0,022	0,030	0,038	0,046	0,060	0,075	0,090	0,10	0,11	0,12	0,13	0,14	49 (37 – 60)
S2	E	0,20	1,0	0,0075	0,015	0,022	0,030	0,038	0,046	0,060	0,075	0,090	0,10	0,11	0,12	0,13	0,14	40 (30 – 50)
S3	E	0,20	1,0	0,0070	0,014	0,022	0,028	0,036	0,042	0,055	0,070	0,085	0,095	0,10	0,11	0,12	0,13	31 (19 – 44)
S11	E	0,40	1,0	0,0060	0,012	0,018	0,024	0,030	0,036	0,048	0,060	0,070	0,080	0,090	0,095	0,10	0,12	95 (65 – 120)
S12	E	0,40	1,0	0,0060	0,012	0,018	0,024	0,030	0,036	0,048	0,060	0,070	0,080	0,090	0,095	0,10	0,12	70 (50 – 95)
S13	E	0,40	0,90	0,0055	0,011	0,016	0,022	0,026	0,032	0,042	0,055	0,065	0,070	0,080	0,085	0,090	0,10	55 (41 – 75)
H5	M/A/D	0,030	0,060	0,010	0,020	0,030	0,040	0,050	0,060	0,080	0,10	0,12	0,14	0,16	0,18	0,20	0,24	90 (70 – 105)
H8	M/A/D	0,030	0,060	0,010	0,020	0,030	0,040	0,050	0,060	0,080	0,10	0,12	0,14	0,16	0,18	0,20	0,24	90 (70 – 105)
H21	M/A/D	0,030	0,060	0,010	0,020	0,030	0,040	0,050	0,060	0,080	0,10	0,12	0,14	0,16	0,18	0,20	0,24	90 (70 – 105)
H31	M/A/D	0,030	0,060	0,010	0,020	0,030	0,040	0,050	0,060	0,080	0,10	0,12	0,14	0,16	0,18	0,20	0,24	65 (55 – 80)
TS1	A/D	0,40	1,4	0,013	0,026	0,038	0,050	0,065	0,080	0,10	0,13	0,15	0,17	0,19	0,20	0,22	0,24	550 (445 – 660)
TP1	A/D	0,40	1,4	0,013	0,026	0,038	0,050	0,065	0,080	0,10	0,13	0,15	0,17	0,19	0,20	0,22	0,24	550 (445 – 660)
GR1	A/D	0,40	1,4	0,013	0,026	0,038	0,050	0,065	0,080	0,10	0,13	0,15	0,17	0,19	0,20	0,22	0,24	540 (430 – 640)

For cutting data recalculations, see page 411-418.

SMG = Seco material group

Coolant = A=air D=dry E=emulsion M=mist spray

v_c = m/min



f_z = mm

a_p (mm)/DC (mm)= factor

a_e (mm)/DC (mm)= factor

All cutting data are target values

Cutting data – JS513 Slot milling

SMG		a _p /DC	f _z														
			1	2	3	4	5	6	8	10	12	14	16	18	20	25	
P1	M/A/D/E	0,70	0,0040	0,0080	0,012	0,016	0,020	0,024	0,032	0,040	0,048	0,055	0,065	0,070	0,080	0,10	175 (150 – 205)
P2	M/A/D/E	0,70	0,0040	0,0080	0,012	0,016	0,020	0,024	0,032	0,040	0,048	0,055	0,065	0,070	0,080	0,10	170 (145 – 200)
P3	M/A/D/E	0,70	0,0040	0,0080	0,012	0,016	0,020	0,024	0,032	0,040	0,048	0,055	0,065	0,070	0,080	0,10	150 (125 – 170)
P4	M/A/D/E	0,70	0,0040	0,0080	0,012	0,016	0,020	0,024	0,032	0,040	0,048	0,055	0,065	0,070	0,080	0,10	130 (110 – 150)
P5	M/A/D/E	0,70	0,0040	0,0080	0,012	0,016	0,020	0,024	0,032	0,040	0,048	0,055	0,065	0,070	0,080	0,10	120 (100 – 140)
P6	M/A/D/E	0,70	0,0040	0,0080	0,012	0,016	0,020	0,024	0,032	0,040	0,048	0,055	0,065	0,070	0,080	0,10	135 (115 – 160)
P7	M/A/D/E	0,70	0,0040	0,0080	0,012	0,016	0,020	0,024	0,032	0,040	0,048	0,055	0,065	0,070	0,080	0,10	130 (105 – 150)
P8	M/A/D/E	0,70	0,0040	0,0080	0,012	0,016	0,020	0,024	0,032	0,040	0,048	0,055	0,065	0,070	0,080	0,10	120 (100 – 140)
P11	M/A/D/E	0,70	0,0040	0,0080	0,012	0,016	0,020	0,024	0,032	0,040	0,048	0,055	0,065	0,070	0,080	0,10	125 (105 – 145)
P12	M/A/D/E	0,60	0,0032	0,0065	0,0095	0,013	0,016	0,019	0,026	0,032	0,038	0,044	0,050	0,055	0,065	0,080	75 (65 – 90)
M1	E/M/A	0,60	0,0032	0,0065	0,0095	0,013	0,016	0,019	0,026	0,032	0,038	0,044	0,050	0,055	0,065	0,080	100 (85 – 110)
M2	E/M/A	0,60	0,0032	0,0065	0,0095	0,013	0,016	0,019	0,026	0,032	0,038	0,044	0,050	0,055	0,065	0,080	80 (70 – 90)
M3	E/M/A	0,50	0,0032	0,0065	0,0095	0,013	0,016	0,019	0,026	0,032	0,038	0,044	0,050	0,055	0,065	0,080	50 (40 – 60)
M4	E/M/A	0,35	0,0032	0,0065	0,0095	0,013	0,016	0,019	0,026	0,032	0,038	0,044	0,050	0,055	0,065	0,080	37 (30 – 45)
M5	E/M/A	0,35	0,0032	0,0065	0,0095	0,013	0,016	0,019	0,026	0,032	0,038	0,044	0,050	0,055	0,065	0,080	31 (25 – 37)
K1	A/D/M/E	0,90	0,0032	0,0065	0,0095	0,013	0,016	0,019	0,026	0,032	0,038	0,044	0,050	0,055	0,065	0,080	150 (130 – 170)
K2	A/D/M/E	0,90	0,0032	0,0065	0,0095	0,013	0,016	0,019	0,026	0,032	0,038	0,044	0,050	0,055	0,065	0,080	130 (110 – 145)
K3	A/D/M/E	0,90	0,0032	0,0065	0,0095	0,013	0,016	0,019	0,026	0,032	0,038	0,044	0,050	0,055	0,065	0,080	110 (95 – 125)
K4	A/D/M/E	0,90	0,0032	0,0065	0,0095	0,013	0,016	0,019	0,026	0,032	0,038	0,044	0,050	0,055	0,065	0,080	105 (90 – 120)
K5	A/D/M/E	0,70	0,0032	0,0065	0,0095	0,013	0,016	0,019	0,026	0,032	0,038	0,044	0,050	0,055	0,065	0,080	130 (110 – 150)
K6	A/D/M/E	0,70	0,0032	0,0065	0,0095	0,013	0,016	0,019	0,026	0,032	0,038	0,044	0,050	0,055	0,065	0,080	190 (160 – 220)
K7	A/D/M/E	0,70	0,0032	0,0065	0,0095	0,013	0,016	0,019	0,026	0,032	0,038	0,044	0,050	0,055	0,065	0,080	165 (140 – 190)
S1	E	0,20	0,0032	0,0065	0,0095	0,013	0,016	0,019	0,026	0,032	0,038	0,044	0,050	0,055	0,065	0,080	40 (30 – 50)
S2	E	0,20	0,0032	0,0065	0,0095	0,013	0,016	0,019	0,026	0,032	0,038	0,044	0,050	0,055	0,065	0,080	32 (24 – 41)
S3	E	0,20	0,0032	0,0065	0,0095	0,013	0,016	0,019	0,026	0,032	0,038	0,044	0,050	0,055	0,065	0,080	25 (15 – 35)
S11	E	0,40	0,0032	0,0065	0,0095	0,013	0,016	0,019	0,026	0,032	0,038	0,044	0,050	0,055	0,065	0,080	85 (60 – 110)
S12	E	0,40	0,0032	0,0065	0,0095	0,013	0,016	0,019	0,026	0,032	0,038	0,044	0,050	0,055	0,065	0,080	65 (47 – 85)
S13	E	0,35	0,0032	0,0065	0,0095	0,013	0,016	0,019	0,026	0,032	0,038	0,044	0,050	0,055	0,065	0,080	50 (36 – 65)
H5	M/A/D	0,070	0,0020	0,0040	0,0060	0,0080	0,010	0,012	0,016	0,020	0,024	0,028	0,032	0,036	0,040	0,050	50 (42 – 65)
H8	M/A/D	0,060	0,0020	0,0040	0,0060	0,0080	0,010	0,012	0,016	0,020	0,024	0,028	0,032	0,036	0,040	0,050	55 (42 – 65)
H21	M/A/D	0,060	0,0020	0,0040	0,0060	0,0080	0,010	0,012	0,016	0,020	0,024	0,028	0,032	0,036	0,040	0,050	55 (42 – 65)
H31	M/A/D	0,060	0,0020	0,0040	0,0060	0,0080	0,010	0,012	0,016	0,020	0,024	0,028	0,032	0,036	0,040	0,050	40 (32 – 48)
TS1	A/D	0,90	0,0080	0,016	0,024	0,032	0,040	0,048	0,065	0,080	0,095	0,11	0,13	0,14	0,16	0,20	500 (400 – 600)
TP1	A/D	0,90	0,0080	0,016	0,024	0,032	0,040	0,048	0,065	0,080	0,095	0,11	0,13	0,14	0,16	0,20	500 (400 – 600)
GR1	A/D	0,80	0,0080	0,016	0,024	0,032	0,040	0,048	0,065	0,080	0,095	0,11	0,13	0,14	0,16	0,20	485 (390 – 580)

For cutting data recalculations, see page 411-418.

SMG = Seco material group

Coolant = A=air D=dry E=emulsion M=mist spray

v_c = m/min

f_z = mm

a_p (mm)/DC (mm)= factor

a_e (mm)/DC (mm)= factor

All cutting data are target values

JS514 – General purpose – Universal – Square – 4 Flutes – Cylindrical – Chamfer



Tolerances:

DMM=h5

DC=e8

Regrind possible if DC is ≥Ø6

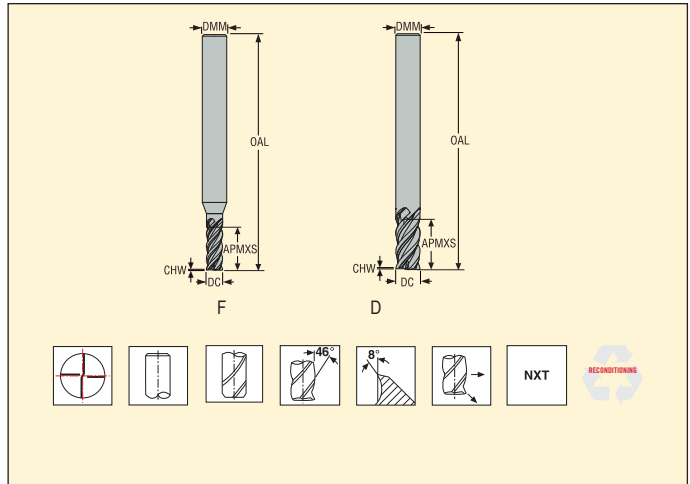

Ordering and Product No.	Designation	Length index	Tool shape	Dimensions in mm					PCEDC	Cylindrical
				DC	DMM	APMXS	OAL	CHW		
02927398	JS514010F2C.0Z4-NXT	2	F	1,0	3	2	38	0,01	4	■
02927399	JS514015F2C.0Z4-NXT	2	F	1,5	3	3	38	0,015	4	■
02927400	JS514020F2C.0Z4-NXT	2	F	2,0	6	5	57	0,02	4	■
02927401	JS514021F2C.0Z4-NXT	2	F	2,0	3	5	38	0,02	4	■
02927402	JS514030F2C.0Z4-NXT	2	F	3,0	6	7	57	0,03	4	■
02927403	JS514030D2C.0Z4-NXT	2	D	3,0	3	7	38	0,03	4	■
02927404	JS514040F2C.0Z4-NXT	2	F	4,0	6	10	57	0,04	4	■
02927405	JS514040D2C.0Z4-NXT	2	D	4,0	4	10	50	0,04	4	■
02927406	JS514050F2C.0Z4-NXT	2	F	5,0	6	12	57	0,05	4	■
02927407	JS514050D2C.0Z4-NXT	2	D	5,0	5	12	50	0,05	4	■
02927408	JS514060D2C.0Z4-NXT	2	D	6,0	6	13	57	0,06	4	■
02927409	JS514080D2C.0Z4-NXT	2	D	8,0	8	18	63	0,08	4	■
02927410	JS514100D2C.0Z4-NXT	2	D	10,0	10	22	72	0,1	4	■
02927411	JS514120D2C.0Z4-NXT	2	D	12,0	12	26	83	0,12	4	■
02927412	JS514160D2C.0Z4-NXT	2	D	16,0	16	32	92	0,16	4	■
02927413	JS514200D2C.0Z4-NXT	2	D	20,0	20	40	104	0,2	4	■
02927414	JS514250D2C.0Z4-NXT	2	D	25,0	25	50	125	0,25	4	■
02927415	JS514010F3C.0Z4-NXT	3	F	1,0	3	3	38	0,01	4	■
02927416	JS514015F3C.0Z4-NXT	3	F	1,5	3	6	38	0,015	4	■
02927417	JS514020F3C.0Z4-NXT	3	F	2,0	6	8	57	0,02	4	■
02927418	JS514030F3C.0Z4-NXT	3	F	3,0	6	12	57	0,03	4	■
02927419	JS514040F3C.0Z4-NXT	3	F	4,0	6	16	57	0,04	4	■
02927420	JS514050F3C.0Z4-NXT	3	F	5,0	6	21	63	0,05	4	■
02927421	JS514060D3C.0Z4-NXT	3	D	6,0	6	23	63	0,06	4	■
02927422	JS514080D3C.0Z4-NXT	3	D	8,0	8	32	80	0,08	4	■
02927423	JS514100D3C.0Z4-NXT	3	D	10,0	10	40	89	0,1	4	■
02927424	JS514120D3C.0Z4-NXT	3	D	12,0	12	45	100	0,12	4	■
02927425	JS514160D3C.0Z4-NXT	3	D	16,0	16	55	115	0,16	4	■
02927426	JS514200D3C.0Z4-NXT	3	D	20,0	20	65	125	0,2	4	■
02927427	JS514250D3C.0Z4-NXT	3	D	25,0	25	80	150	0,25	4	■
02927428	JS514020F4C.0Z4-NXT	4	F	2,0	6	10	57	0,02	4	■
02927429	JS514030F4C.0Z4-NXT	4	F	3,0	6	17	57	0,03	4	■
02927430	JS514040F4C.0Z4-NXT	4	F	4,0	6	25	63	0,04	4	■
02927431	JS514050F4C.0Z4-NXT	4	F	5,0	6	28	75	0,05	4	■
02927432	JS514060D4C.0Z4-NXT	4	D	6,0	6	35	75	0,06	4	■
02927433	JS514080D4C.0Z4-NXT	4	D	8,0	8	45	100	0,08	4	■
02927434	JS514100D4C.0Z4-NXT	4	D	10,0	10	55	100	0,1	4	■

■ Stock standard. Subject to change refer to current price- and stock-list

JS514 – General purpose – Universal – Square – 4 Flutes – Weldon – Chamfer



Tolerances:

DMM=h5

DC=e8

Regrind possible if DC is ≥Ø6

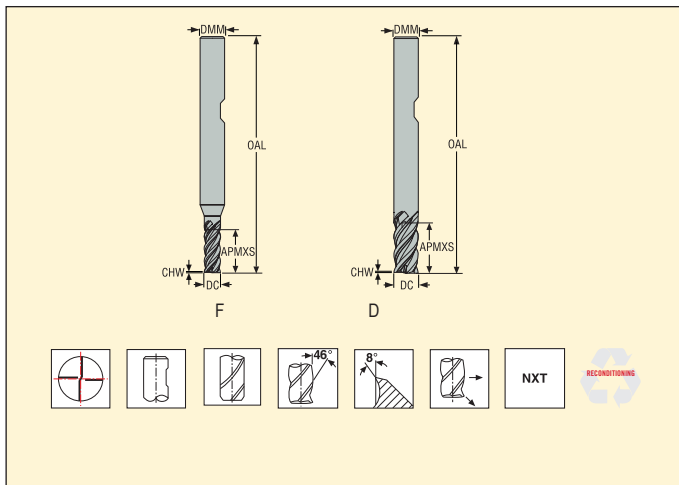

Ordering and Product No.	Designation	Length index	Tool shape	Dimensions in mm					PCE/DC	Weldon
				DC	DMM	APMXS	OAL	CHW		
02927441	JS514020F2C.3Z4-NXT	2	F	2,0	6	5	57	0,02	4	<input type="checkbox"/>
02927442	JS514030F2C.3Z4-NXT	2	F	3,0	6	7	57	0,03	4	<input type="checkbox"/>
02927443	JS514040F2C.3Z4-NXT	2	F	4,0	6	10	57	0,04	4	<input type="checkbox"/>
02927444	JS514050F2C.3Z4-NXT	2	F	5,0	6	12	57	0,05	4	<input type="checkbox"/>
02927445	JS514060D2C.3Z4-NXT	2	D	6,0	6	13	57	0,06	4	<input type="checkbox"/>
02927446	JS514080D2C.3Z4-NXT	2	D	8,0	8	18	63	0,08	4	<input type="checkbox"/>
02927447	JS514100D2C.3Z4-NXT	2	D	10,0	10	22	72	0,1	4	<input checked="" type="checkbox"/>
02927448	JS514120D2C.3Z4-NXT	2	D	12,0	12	26	83	0,12	4	<input checked="" type="checkbox"/>
02927449	JS514160D2C.3Z4-NXT	2	D	16,0	16	32	92	0,16	4	<input checked="" type="checkbox"/>
02927450	JS514200D2C.3Z4-NXT	2	D	20,0	20	40	104	0,2	4	<input checked="" type="checkbox"/>
02927451	JS514250D2C.3Z4-NXT	2	D	25,0	25	50	125	0,25	4	<input type="checkbox"/>
02927452	JS514020F3C.3Z4-NXT	3	F	2,0	6	8	57	0,02	4	<input type="checkbox"/>
02927453	JS514030F3C.3Z4-NXT	3	F	3,0	6	12	57	0,03	4	<input type="checkbox"/>
02927454	JS514040F3C.3Z4-NXT	3	F	4,0	6	16	57	0,04	4	<input type="checkbox"/>
02927455	JS514050F3C.3Z4-NXT	3	F	5,0	6	21	63	0,05	4	<input type="checkbox"/>
02927456	JS514060D3C.3Z4-NXT	3	D	6,0	6	23	63	0,06	4	<input type="checkbox"/>
02927457	JS514080D3C.3Z4-NXT	3	D	8,0	8	32	80	0,08	4	<input type="checkbox"/>
02927458	JS514100D3C.3Z4-NXT	3	D	10,0	10	40	89	0,1	4	<input checked="" type="checkbox"/>
02927459	JS514120D3C.3Z4-NXT	3	D	12,0	12	45	100	0,12	4	<input type="checkbox"/>
02927460	JS514160D3C.3Z4-NXT	3	D	16,0	16	55	115	0,16	4	<input type="checkbox"/>
02927461	JS514200D3C.3Z4-NXT	3	D	20,0	20	65	125	0,2	4	<input type="checkbox"/>
02927462	JS514250D3C.3Z4-NXT	3	D	25,0	25	80	150	0,25	4	<input type="checkbox"/>
02927463	JS514020F4C.3Z4-NXT	4	F	2,0	6	10	57	0,02	4	<input type="checkbox"/>
02927464	JS514030F4C.3Z4-NXT	4	F	3,0	6	17	57	0,03	4	<input type="checkbox"/>
02927465	JS514040F4C.3Z4-NXT	4	F	4,0	6	25	63	0,04	4	<input type="checkbox"/>
02927466	JS514050F4C.3Z4-NXT	4	F	5,0	6	28	75	0,05	4	<input type="checkbox"/>
02927467	JS514060D4C.3Z4-NXT	4	D	6,0	6	35	75	0,06	4	<input type="checkbox"/>
02927468	JS514080D4C.3Z4-NXT	4	D	8,0	8	45	100	0,08	4	<input checked="" type="checkbox"/>
02927469	JS514100D4C.3Z4-NXT	4	D	10,0	10	55	100	0,1	4	<input checked="" type="checkbox"/>
02927470	JS514120D4C.3Z4-NXT	4	D	12,0	12	65	125	0,12	4	<input type="checkbox"/>
02927471	JS514160D4C.3Z4-NXT	4	D	16,0	16	80	150	0,16	4	<input type="checkbox"/>
02927472	JS514200D4C.3Z4-NXT	4	D	20,0	20	90	150	0,2	4	<input type="checkbox"/>
02927473	JS514250D4C.3Z4-NXT	4	D	25,0	25	110	196	0,25	4	<input checked="" type="checkbox"/>

■ Stock standard. Subject to change refer to current price- and stock-list Weldon available, delivery time is 3 days.

Cutting data – JS514 Slot milling

SMG		a_p /DC	f_z													v_c
			1	2	3	4	5	6	8	10	12	16	20	25		
P1	M/A/D/E	0,50	0,0050	0,010	0,015	0,020	0,026	0,030	0,040	0,050	0,060	0,080	0,10	0,13	175 (150 – 205)	
P2	M/A/D/E	0,50	0,0050	0,010	0,015	0,020	0,026	0,030	0,040	0,050	0,060	0,080	0,10	0,13	175 (145 – 200)	
P3	M/A/D/E	0,50	0,0050	0,010	0,015	0,020	0,026	0,030	0,040	0,050	0,060	0,080	0,10	0,13	150 (125 – 170)	
P4	M/A/D/E	0,50	0,0050	0,010	0,015	0,020	0,026	0,030	0,040	0,050	0,060	0,080	0,10	0,13	130 (110 – 150)	
P5	M/A/D/E	0,50	0,0050	0,010	0,015	0,020	0,026	0,030	0,040	0,050	0,060	0,080	0,10	0,13	120 (100 – 140)	
P6	M/A/D/E	0,50	0,0050	0,010	0,015	0,020	0,026	0,030	0,040	0,050	0,060	0,080	0,10	0,13	135 (115 – 160)	
P7	M/A/D/E	0,50	0,0050	0,010	0,015	0,020	0,026	0,030	0,040	0,050	0,060	0,080	0,10	0,13	130 (105 – 150)	
P8	M/A/D/E	0,50	0,0050	0,010	0,015	0,020	0,026	0,030	0,040	0,050	0,060	0,080	0,10	0,13	120 (100 – 140)	
P11	M/A/D/E	0,50	0,0050	0,010	0,015	0,020	0,026	0,030	0,040	0,050	0,060	0,080	0,10	0,13	125 (105 – 145)	
P12	M/A/D/E	0,40	0,0050	0,010	0,015	0,020	0,026	0,030	0,040	0,050	0,060	0,080	0,095	0,11	75 (60 – 85)	
M1	E	0,50	0,0020	0,0040	0,0060	0,0080	0,010	0,012	0,016	0,020	0,024	0,032	0,040	0,050	100 (85 – 110)	
M2	E	0,50	0,0020	0,0040	0,0060	0,0080	0,010	0,012	0,016	0,020	0,024	0,032	0,040	0,050	80 (70 – 90)	
M3	E	0,40	0,0020	0,0040	0,0060	0,0080	0,010	0,012	0,016	0,020	0,024	0,032	0,040	0,050	50 (40 – 60)	
M4	E	0,30	0,0020	0,0040	0,0060	0,0080	0,010	0,012	0,016	0,020	0,024	0,032	0,040	0,050	38 (30 – 46)	
M5	E	0,30	0,0020	0,0040	0,0060	0,0080	0,010	0,012	0,016	0,020	0,024	0,032	0,040	0,050	32 (25 – 38)	
K1	E	0,60	0,0030	0,0060	0,0090	0,012	0,015	0,018	0,024	0,030	0,036	0,048	0,060	0,075	150 (130 – 170)	
K2	E	0,60	0,0030	0,0060	0,0090	0,012	0,015	0,018	0,024	0,030	0,036	0,048	0,060	0,075	130 (115 – 150)	
K3	E	0,60	0,0030	0,0060	0,0090	0,012	0,015	0,018	0,024	0,030	0,036	0,048	0,060	0,075	110 (95 – 125)	
K4	E	0,60	0,0030	0,0060	0,0090	0,012	0,015	0,018	0,024	0,030	0,036	0,048	0,060	0,075	105 (90 – 120)	
K5	E	0,50	0,0030	0,0060	0,0090	0,012	0,015	0,018	0,024	0,030	0,036	0,048	0,060	0,075	130 (110 – 150)	
K6	E	0,50	0,0030	0,0060	0,0090	0,012	0,015	0,018	0,024	0,030	0,036	0,048	0,060	0,075	195 (165 – 225)	
K7	E	0,50	0,0030	0,0060	0,0090	0,012	0,015	0,018	0,024	0,030	0,036	0,048	0,060	0,075	170 (140 – 195)	
N11	E	0,50	0,0050	0,010	0,015	0,020	0,026	0,030	0,040	0,050	0,060	0,080	0,10	0,13	300 (200 – 405)	
S1	E	0,20	0,0020	0,0040	0,0060	0,0080	0,010	0,012	0,016	0,020	0,024	0,032	0,040	0,050	43 (32 – 55)	
S2	E	0,20	0,0020	0,0040	0,0060	0,0080	0,010	0,012	0,016	0,020	0,024	0,032	0,040	0,050	35 (26 – 44)	
S3	E	0,20	0,0020	0,0040	0,0060	0,0080	0,010	0,012	0,016	0,020	0,024	0,032	0,040	0,050	25 (15 – 36)	
S11	E	0,30	0,0050	0,010	0,015	0,020	0,026	0,030	0,040	0,050	0,060	0,080	0,10	0,13	100 (75 – 130)	
S12	E	0,30	0,0050	0,010	0,015	0,020	0,026	0,030	0,040	0,050	0,060	0,080	0,10	0,13	80 (55 – 100)	
S13	E	0,25	0,0050	0,010	0,015	0,020	0,026	0,030	0,040	0,050	0,060	0,080	0,10	0,13	60 (44 – 80)	
H5	M/A/D	0,20	0,0020	0,0040	0,0060	0,0080	0,010	0,012	0,016	0,020	0,024	0,032	0,040	0,050	50 (41 – 60)	
H8	M/A/D	0,20	0,0020	0,0040	0,0060	0,0080	0,010	0,012	0,016	0,020	0,024	0,032	0,040	0,050	50 (41 – 60)	
H11	M/A/D	0,20	0,0020	0,0040	0,0060	0,0080	0,010	0,012	0,016	0,020	0,024	0,032	0,040	0,050	55 (47 – 65)	
H12	M/A/D	0,35	0,0034	0,0065	0,010	0,013	0,017	0,020	0,026	0,034	0,040	0,048	0,055	0,065	47 (39 – 55)	
H21	M/A/D	0,20	0,0020	0,0040	0,0060	0,0080	0,010	0,012	0,016	0,020	0,024	0,032	0,040	0,050	50 (41 – 60)	
H31	M/A/D	0,20	0,0020	0,0040	0,0060	0,0080	0,010	0,012	0,016	0,020	0,024	0,032	0,040	0,050	39 (31 – 47)	
GR1	A	0,50	0,013	0,026	0,038	0,050	0,065	0,075	0,10	0,13	0,15	0,19	0,22	0,24	440 (355 – 530)	

For cutting data recalculations, see page 411-418.

SMG = Seco material group

Coolant = A=air D=dry E=emulsion M=mist spray

v_c = m/min

f_z = mm

a_p (mm)/DC (mm)= factor

All cutting data are target values

Cutting data – JS514 Side milling

SMG		a _g /DC	a _p /DC	f _z												v _c
				1	2	3	4	5	6	8	10	12	16	20	25	
P1	M/A/D/E	0,30	1,0	0,0095	0,019	0,030	0,038	0,048	0,060	0,075	0,095	0,11	0,14	0,16	0,19	205 (175 – 235)
P2	M/A/D/E	0,30	1,0	0,010	0,020	0,030	0,040	0,050	0,060	0,080	0,10	0,12	0,14	0,17	0,19	195 (165 – 230)
P3	M/A/D/E	0,30	1,0	0,0095	0,019	0,028	0,038	0,046	0,055	0,075	0,095	0,11	0,14	0,16	0,18	170 (145 – 200)
P4	M/A/D/E	0,30	1,0	0,0090	0,018	0,028	0,036	0,046	0,055	0,075	0,090	0,11	0,13	0,15	0,18	155 (130 – 175)
P5	M/A/D/E	0,30	1,0	0,0090	0,018	0,026	0,036	0,044	0,055	0,070	0,090	0,11	0,13	0,15	0,17	140 (120 – 165)
P6	M/A/D/E	0,30	1,0	0,0090	0,018	0,026	0,036	0,044	0,055	0,070	0,090	0,10	0,13	0,15	0,17	160 (130 – 185)
P7	M/A/D/E	0,30	1,0	0,0090	0,018	0,026	0,036	0,044	0,055	0,070	0,090	0,10	0,13	0,15	0,17	150 (125 – 175)
P8	M/A/D/E	0,30	1,0	0,0095	0,019	0,028	0,038	0,046	0,055	0,075	0,095	0,11	0,14	0,16	0,18	140 (115 – 165)
P11	M/A/D/E	0,30	1,0	0,0090	0,018	0,026	0,036	0,044	0,055	0,070	0,090	0,10	0,13	0,15	0,17	145 (120 – 170)
P12	M/A/D/E	0,30	0,80	0,0060	0,012	0,018	0,024	0,030	0,036	0,048	0,060	0,070	0,090	0,10	0,12	95 (80 – 110)
M1	E/M/A	0,30	1,0	0,0040	0,0080	0,012	0,016	0,020	0,024	0,032	0,040	0,048	0,060	0,070	0,075	120 (105 – 135)
M2	E/M/A	0,30	1,0	0,0036	0,0075	0,011	0,015	0,018	0,022	0,030	0,036	0,044	0,055	0,060	0,070	95 (85 – 110)
M3	E/M/A	0,30	1,0	0,0040	0,0080	0,012	0,016	0,020	0,024	0,032	0,040	0,048	0,060	0,070	0,075	60 (48 – 70)
M4	E/M/A	0,30	0,70	0,0036	0,0070	0,011	0,014	0,018	0,022	0,028	0,036	0,042	0,050	0,060	0,070	46 (37 – 55)
M5	E/M/A	0,30	0,70	0,0036	0,0070	0,011	0,014	0,018	0,022	0,028	0,036	0,042	0,050	0,060	0,070	38 (30 – 46)
K1	A/D/M/E	0,30	1,0	0,0090	0,018	0,026	0,036	0,044	0,055	0,070	0,090	0,11	0,13	0,15	0,17	160 (140 – 180)
K2	A/D/M/E	0,30	1,0	0,0080	0,016	0,024	0,032	0,040	0,048	0,065	0,080	0,095	0,12	0,14	0,16	145 (125 – 165)
K3	A/D/M/E	0,30	1,0	0,0080	0,016	0,024	0,032	0,040	0,048	0,065	0,080	0,095	0,12	0,14	0,16	120 (105 – 140)
K4	A/D/M/E	0,30	1,0	0,0080	0,016	0,024	0,032	0,040	0,048	0,065	0,080	0,095	0,12	0,14	0,16	115 (100 – 130)
K5	A/D/M/E	0,30	1,0	0,0070	0,014	0,020	0,028	0,034	0,042	0,055	0,070	0,085	0,10	0,12	0,13	150 (125 – 170)
K6	A/D/M/E	0,30	1,0	0,0080	0,016	0,024	0,032	0,038	0,046	0,060	0,080	0,090	0,11	0,13	0,15	210 (180 – 245)
K7	A/D/M/E	0,30	1,0	0,0070	0,014	0,020	0,028	0,034	0,042	0,055	0,070	0,085	0,10	0,12	0,13	190 (160 – 220)
N1	E/M/A	0,30	1,0	0,0090	0,018	0,026	0,036	0,044	0,055	0,070	0,090	0,11	0,13	0,15	0,17	500 (400 – 600)
N2	E/M/A	0,30	1,0	0,0090	0,018	0,026	0,036	0,044	0,055	0,070	0,090	0,11	0,13	0,15	0,17	320 (255 – 385)
N3	E/M/A	0,30	1,0	0,0090	0,018	0,026	0,036	0,044	0,055	0,070	0,090	0,11	0,13	0,15	0,17	215 (170 – 255)
N11	E/M/A	0,30	1,0	0,0090	0,018	0,026	0,036	0,044	0,055	0,070	0,090	0,11	0,13	0,15	0,17	355 (235 – 470)
S1	E	0,20	0,60	0,0044	0,0085	0,013	0,017	0,022	0,026	0,034	0,044	0,050	0,065	0,075	0,085	55 (41 – 70)
S2	E	0,20	0,60	0,0044	0,0085	0,013	0,017	0,022	0,026	0,034	0,044	0,050	0,065	0,075	0,085	44 (33 – 55)
S3	E	0,20	0,60	0,0040	0,0080	0,012	0,016	0,020	0,024	0,032	0,040	0,048	0,060	0,070	0,075	33 (20 – 46)
S11	E	0,30	1,0	0,0090	0,018	0,026	0,036	0,044	0,055	0,070	0,090	0,11	0,13	0,15	0,17	120 (85 – 155)
S12	E	0,30	1,0	0,0090	0,018	0,026	0,036	0,044	0,055	0,070	0,090	0,11	0,13	0,15	0,17	90 (65 – 120)
S13	E	0,30	0,90	0,0080	0,016	0,024	0,032	0,040	0,048	0,065	0,080	0,095	0,12	0,13	0,15	75 (50 – 95)
H5	M/A/D	0,030	0,60	0,015	0,030	0,044	0,060	0,075	0,090	0,12	0,15	0,18	0,24	0,26	0,30	80 (65 – 95)
H8	M/A/D	0,030	0,60	0,012	0,024	0,036	0,048	0,060	0,075	0,095	0,12	0,14	0,18	0,20	0,22	80 (65 – 100)
H21	M/A/D	0,030	0,60	0,012	0,024	0,036	0,048	0,060	0,075	0,095	0,12	0,14	0,18	0,20	0,22	80 (65 – 100)
H31	M/A/D	0,030	0,60	0,010	0,020	0,032	0,042	0,050	0,065	0,085	0,10	0,12	0,15	0,18	0,20	65 (50 – 75)
TS1	A/D	0,40	1,4	0,0090	0,018	0,026	0,036	0,044	0,055	0,070	0,090	0,11	0,13	0,15	0,17	610 (510 – 710)
TP1	A/D	0,40	1,4	0,0090	0,018	0,026	0,036	0,044	0,055	0,070	0,090	0,11	0,13	0,15	0,17	610 (510 – 710)
GR1	A/D	0,40	1,0	0,013	0,026	0,038	0,050	0,065	0,080	0,10	0,13	0,15	0,19	0,22	0,24	550 (445 – 660)

For cutting data recalculations, see page 411-418.

SMG = Seco material group

Coolant = A=air D=dry E=emulsion M=mist spray

v_c = m/min

f_z = mm

a_p (mm)/DC (mm) = factor

a_g (mm)/DC (mm) = factor

All cutting data are target values

JS553 - High performance - Universal - Square - 3 Flutes - Cylindrical - Corner radius



Tolerances:

DMM=h5

DC=e7

RE= ±0,02 mm

Regrind possible if DC is ≥Ø6

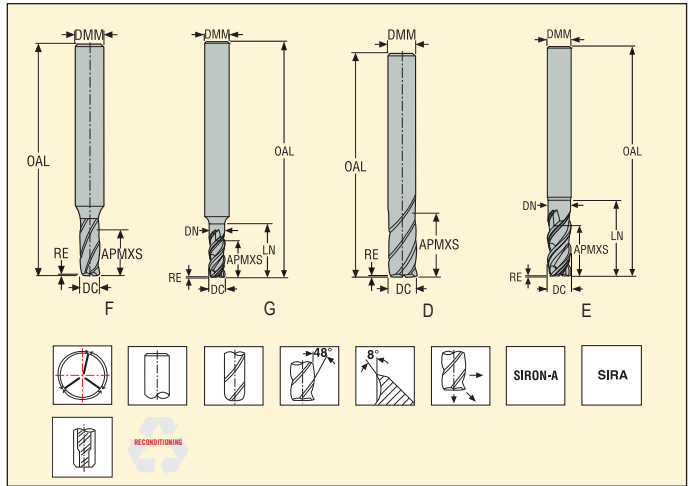

Ordering and Product No.	Designation	Length index	Tool shape	Dimensions in mm							PCEDC	Cylindrical
				DC	DMM	APMXS	OAL	LN	DN	RE		
02881683	JS553020G2R050.0Z3-SIRA	2	G	2,0	6	5	57	8	1,9	0,5	3	■
02733908	553030R015Z3.0-SIRON-A	2	F	3,0	6	7	50	9	3,0	0,15	3	■
02881684	JS553030G2R050.0Z3-SIRA	2	G	3,0	6	7	57	11	2,85	0,5	3	■
02733911	553040R020Z3.0-SIRON-A	2	F	4,0	6	10	55	12	4,0	0,2	3	■
02881685	JS553040G2R050.0Z3-SIRA	2	G	4,0	6	10	57	13	3,8	0,5	3	■
02687282	553050R020Z3.0-SIRON-A	2	F	5,0	6	12	55	15	5,0	0,2	3	■
02881686	JS553050G2R050.0Z3-SIRA	2	G	5,0	6	10	57	15	4,75	0,5	3	■
02679369	553060R020Z3.0-SIRON-A	2	D	6,0	6	14	55	-	-	0,2	3	■
02881687	JS553060E2R050.0Z3-SIRA	2	E	6,0	6	14	57	19	5,7	0,5	3	■
02881688	JS553060E2R100.0Z3-SIRA	2	E	6,0	6	14	57	19	5,7	1,0	3	■
02679372	553080R050Z3.0-SIRON-A	2	D	8,0	8	18	60	-	-	0,5	3	■
02679375	553100R050Z3.0-SIRON-A	2	D	10,0	10	22	70	-	-	0,5	3	■
02679376	553100R100Z3.0-SIRON-A	2	D	10,0	10	22	70	-	-	1,0	3	■
02810365	553100R250Z3.0-SIRON-A	2	D	10,0	10	22	70	-	-	2,5	3	■
02810366	553100R310Z3.0-SIRON-A	2	D	10,0	10	22	70	-	-	3,1	3	■
02810364	553100R200Z3.0-SIRON-A	2	D	10,0	10	22	70	-	-	2,0	3	■
02679381	553120R050Z3.0-SIRON-A	2	D	12,0	12	26	80	-	-	0,5	3	■
02679382	553120R100Z3.0-SIRON-A	2	D	12,0	12	26	80	-	-	1,0	3	■
02810367	553120R200Z3.0-SIRON-A	2	D	12,0	12	26	80	-	-	2,0	3	■
02810368	553120R250Z3.0-SIRON-A	2	D	12,0	12	26	80	-	-	2,5	3	■
02810369	553120R310Z3.0-SIRON-A	2	D	12,0	12	26	80	-	-	3,1	3	■
02679385	553160R050Z3.0-SIRON-A	2	D	16,0	16	34	90	-	-	0,5	3	■
02679386	553160R100Z3.0-SIRON-A	2	D	16,0	16	34	90	-	-	1,0	3	■
02810370	553160R200Z3.0-SIRON-A	2	D	16,0	16	34	90	-	-	2,0	3	■
02810372	553160R310Z3.0-SIRON-A	2	D	16,0	16	34	90	-	-	3,1	3	■
02810373	553160R400Z3.0-SIRON-A	2	D	16,0	16	34	90	-	-	4,0	3	■
02810371	553160R250Z3.0-SIRON-A	2	D	16,0	16	34	90	-	-	2,5	3	■
02679390	553200R050Z3.0-SIRON-A	2	D	20,0	20	42	110	-	-	0,5	3	■
02679391	553200R100Z3.0-SIRON-A	2	D	20,0	20	42	110	-	-	1,0	3	■
02881689	JS553200E2R200.0Z3-SIRA	2	E	20,0	20	42	110	54	19,0	2,0	3	■
02679395	553250R050Z3.0-SIRON-A	2	D	25,0	25	52	125	-	-	0,5	3	■
02679396	553250R100Z3.0-SIRON-A	2	D	25,0	25	52	125	-	-	1,0	3	■

■ Stock standard. Subject to change refer to current price- and stock-list

JS553 - High performance - Universal - Square - 3 Flutes - Weldon - Corner radius



Tolerances:
 DMM=h5
 DC=e7
 RE= ±0,02 mm
 Regrind possible if DC is ≥Ø6

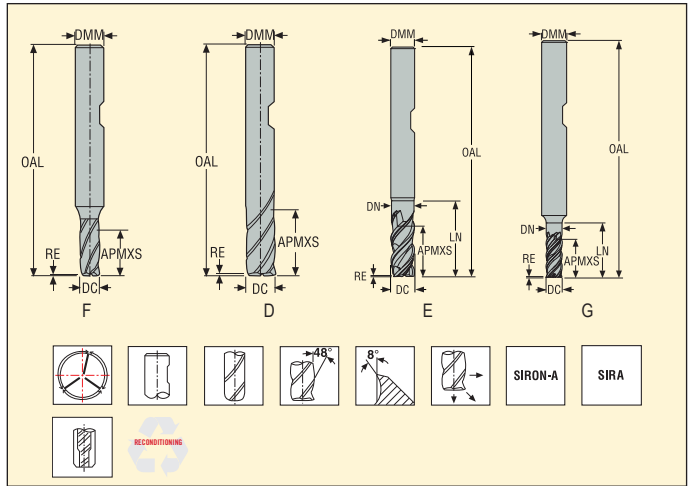

Ordering and Product No.	Designation	Length index	Tool shape	Dimensions in mm						RE	PCEDC	Weldon
				DC	DMM	APMXS	OAL	LN	DN			
02881690	JS553020G2R050.3Z3-SIRA	2	G	2,0	6	5	57	8	1,9	0,5	3	<input type="checkbox"/>
02733941	553030R015Z3.0-SIRON-AW	2	F	3,0	6	7	50	9	3,0	0,15	3	<input type="checkbox"/>
02881691	JS553030G2R050.3Z3-SIRA	2	G	3,0	6	7	57	11	2,85	0,5	3	<input type="checkbox"/>
02733944	553040R020Z3.0-SIRON-AW	2	F	4,0	6	10	55	12	4,0	0,2	3	<input type="checkbox"/>
02881692	JS553040G2R050.3Z3-SIRA	2	G	4,0	6	10	57	13	3,8	0,5	3	<input type="checkbox"/>
02703763	553050R020Z3.0-SIRON-AW	2	F	5,0	6	12	55	15	5,0	0,2	3	<input type="checkbox"/>
02881693	JS553050G2R050.3Z3-SIRA	2	G	5,0	6	10	57	15	4,75	0,5	3	<input type="checkbox"/>
02700364	553060R020Z3.0-SIRON-AW	2	D	6,0	6	14	55	-	-	0,2	3	<input type="checkbox"/>
02881694	JS553060E2R050.3Z3-SIRA	2	E	6,0	6	14	57	19	5,7	0,5	3	<input type="checkbox"/>
02881695	JS553060E2R100.3Z3-SIRA	2	E	6,0	6	14	57	19	5,7	1,0	3	<input checked="" type="checkbox"/>
02700366	553080R050Z3.0-SIRON-AW	2	D	8,0	8	18	60	-	-	0,5	3	<input checked="" type="checkbox"/>
02700369	553100R050Z3.0-SIRON-AW	2	D	10,0	10	22	70	-	-	0,5	3	<input type="checkbox"/>
02700371	553100R100Z3.0-SIRON-AW	2	D	10,0	10	22	70	-	-	1,0	3	<input type="checkbox"/>
02810422	553100R200Z3.3-SIRON-A	2	D	10,0	10	22	70	-	-	2,0	3	<input type="checkbox"/>
02810423	553100R250Z3.3-SIRON-A	2	D	10,0	10	22	70	-	-	2,5	3	<input type="checkbox"/>
02810424	553100R310Z3.3-SIRON-A	2	D	10,0	10	22	70	-	-	3,1	3	<input type="checkbox"/>
02700373	553120R050Z3.0-SIRON-AW	2	D	12,0	12	26	80	-	-	0,5	3	<input type="checkbox"/>
02700374	553120R100Z3.0-SIRON-AW	2	D	12,0	12	26	80	-	-	1,0	3	<input type="checkbox"/>
02810425	553120R200Z3.3-SIRON-A	2	D	12,0	12	26	80	-	-	2,0	3	<input type="checkbox"/>
02810426	553120R250Z3.3-SIRON-A	2	D	12,0	12	26	80	-	-	2,5	3	<input type="checkbox"/>
02810427	553120R310Z3.3-SIRON-A	2	D	12,0	12	26	80	-	-	3,1	3	<input type="checkbox"/>
02700378	553160R050Z3.0-SIRON-AW	2	D	16,0	16	34	90	-	-	0,5	3	<input type="checkbox"/>
02700381	553160R100Z3.0-SIRON-AW	2	D	16,0	16	34	90	-	-	1,0	3	<input type="checkbox"/>
02810428	553160R200Z3.3-SIRON-A	2	D	16,0	16	34	90	-	-	2,0	3	<input type="checkbox"/>
02810429	553160R250Z3.3-SIRON-A	2	D	16,0	16	34	90	-	-	2,5	3	<input type="checkbox"/>
02810430	553160R310Z3.3-SIRON-A	2	D	16,0	16	34	90	-	-	3,1	3	<input type="checkbox"/>
02810431	553160R400Z3.3-SIRON-A	2	D	16,0	16	34	90	-	-	4,0	3	<input type="checkbox"/>
02700383	553200R050Z3.0-SIRON-AW	2	D	20,0	20	42	110	-	-	0,5	3	<input checked="" type="checkbox"/>
02700384	553200R100Z3.0-SIRON-AW	2	D	20,0	20	42	110	-	-	1,0	3	<input type="checkbox"/>
02881696	JS553200E2R200.3Z3-SIRA	2	E	20,0	20	42	110	54	19,0	2,0	3	<input type="checkbox"/>
02700385	553250R100Z3.0-SIRON-AW	2	D	25,0	25	52	125	-	-	1,0	3	<input type="checkbox"/>
02700386	553250R050Z3.0-SIRON-AW	2	D	25,0	25	52	125	-	-	0,5	3	<input type="checkbox"/>

■ Stock standard. Subject to change refer to current price- and stock-list Weldon available, delivery time is 3 days.

Cutting data – JS553 Slot milling

SMG		a _p /DC	f _z													v _c
			2	3	4	5	6	8	10	12	14	16	20	25		
P1	M/A/D/E	1,0	0,014	0,022	0,028	0,036	0,042	0,055	0,070	0,085	0,10	0,11	0,14	0,18	205 (180 – 230)	
P2	M/A/D/E	1,0	0,014	0,022	0,028	0,036	0,042	0,055	0,070	0,085	0,10	0,11	0,14	0,18	200 (175 – 225)	
P3	M/A/D/E	1,0	0,014	0,022	0,028	0,036	0,042	0,055	0,070	0,085	0,10	0,11	0,14	0,18	170 (150 – 195)	
P4	M/A/D/E	1,0	0,014	0,022	0,028	0,036	0,042	0,055	0,070	0,085	0,10	0,11	0,14	0,18	150 (130 – 170)	
P5	M/A/D/E	1,0	0,014	0,022	0,028	0,036	0,042	0,055	0,070	0,085	0,10	0,11	0,14	0,17	140 (100 – 160)	
P6	M/A/D/E	1,0	0,014	0,022	0,028	0,036	0,042	0,055	0,070	0,085	0,10	0,11	0,14	0,17	160 (115 – 180)	
P7	M/A/D/E	1,0	0,014	0,022	0,028	0,036	0,042	0,055	0,070	0,085	0,10	0,11	0,14	0,17	150 (105 – 170)	
P8	M/A/D/E	1,0	0,014	0,022	0,028	0,036	0,042	0,055	0,070	0,085	0,10	0,11	0,14	0,18	140 (100 – 160)	
P11	M/A/D/E	1,0	0,014	0,022	0,028	0,036	0,042	0,055	0,070	0,085	0,10	0,11	0,14	0,17	145 (105 – 165)	
P12	M/A/D/E	0,80	0,010	0,015	0,020	0,024	0,030	0,040	0,050	0,060	0,065	0,075	0,085	0,095	95 (65 – 105)	
M1	E	0,80	0,010	0,015	0,020	0,026	0,030	0,040	0,050	0,060	0,070	0,080	0,10	0,11	95 (85 – 110)	
M2	E	0,80	0,010	0,015	0,020	0,026	0,030	0,040	0,050	0,060	0,070	0,080	0,090	0,10	80 (70 – 90)	
M3	E	0,70	0,0080	0,012	0,016	0,020	0,024	0,032	0,040	0,050	0,055	0,065	0,080	0,095	50 (40 – 60)	
M4	E	0,50	0,0080	0,012	0,016	0,020	0,024	0,032	0,040	0,050	0,055	0,065	0,075	0,085	38 (30 – 45)	
M5	E	0,50	0,0080	0,012	0,016	0,020	0,024	0,032	0,040	0,050	0,055	0,065	0,075	0,085	32 (25 – 38)	
K1	E	1,0	0,010	0,015	0,020	0,026	0,030	0,040	0,050	0,060	0,070	0,080	0,10	0,13	170 (145 – 190)	
K2	E	1,0	0,010	0,015	0,020	0,026	0,030	0,040	0,050	0,060	0,070	0,080	0,10	0,13	145 (125 – 165)	
K3	E	1,0	0,010	0,015	0,020	0,026	0,030	0,040	0,050	0,060	0,070	0,080	0,10	0,13	125 (110 – 140)	
K4	E	1,0	0,010	0,015	0,020	0,026	0,030	0,040	0,050	0,060	0,070	0,080	0,10	0,13	120 (105 – 130)	
K5	E	0,80	0,010	0,015	0,020	0,026	0,030	0,040	0,050	0,060	0,070	0,080	0,10	0,13	140 (120 – 160)	
K6	E	0,80	0,010	0,015	0,020	0,026	0,030	0,040	0,050	0,060	0,070	0,080	0,10	0,13	210 (180 – 240)	
K7	E	0,80	0,010	0,015	0,020	0,026	0,030	0,040	0,050	0,060	0,070	0,080	0,10	0,13	180 (155 – 205)	
N1	E	0,70	0,010	0,015	0,020	0,026	0,030	0,040	0,050	0,060	0,070	0,080	0,10	0,13	650 (540 – 760)	
N2	E	0,70	0,010	0,015	0,020	0,026	0,030	0,040	0,050	0,060	0,070	0,080	0,10	0,13	420 (350 – 490)	
N3	E	0,70	0,010	0,015	0,020	0,026	0,030	0,040	0,050	0,060	0,070	0,080	0,10	0,13	280 (235 – 325)	
N11	E	0,60	0,010	0,015	0,020	0,026	0,030	0,040	0,050	0,060	0,070	0,080	0,10	0,13	315 (260 – 365)	
S1	E	0,30	0,0065	0,0095	0,013	0,016	0,019	0,026	0,032	0,038	0,044	0,050	0,065	0,080	40 (30 – 50)	
S2	E	0,30	0,0065	0,0095	0,013	0,016	0,019	0,026	0,032	0,038	0,044	0,050	0,065	0,080	32 (24 – 41)	
S3	E	0,30	0,0065	0,0095	0,013	0,016	0,019	0,026	0,032	0,038	0,044	0,050	0,065	0,080	25 (15 – 35)	
S11	E	0,50	0,010	0,015	0,020	0,024	0,030	0,040	0,050	0,060	0,070	0,080	0,10	0,11	90 (65 – 120)	
S12	E	0,50	0,010	0,015	0,020	0,024	0,030	0,040	0,050	0,060	0,070	0,080	0,10	0,11	70 (50 – 90)	
S13	E	0,45	0,010	0,015	0,020	0,024	0,030	0,040	0,050	0,060	0,070	0,075	0,090	0,10	55 (39 – 70)	
H5	M/A/D	0,60	0,0040	0,0060	0,0080	0,010	0,012	0,016	0,020	0,024	0,028	0,032	0,040	0,050	50 (41 – 60)	
H8	M/A/D	0,50	0,0040	0,0060	0,0080	0,010	0,012	0,016	0,020	0,024	0,028	0,032	0,040	0,050	50 (41 – 60)	
H11	M/A/D	0,60	0,0040	0,0060	0,0080	0,010	0,012	0,016	0,020	0,024	0,028	0,032	0,040	0,050	70 (50 – 80)	
H12	M/A/D	0,70	0,0060	0,0090	0,012	0,015	0,018	0,024	0,030	0,034	0,038	0,042	0,050	0,055	60 (43 – 70)	
H21	M/A/D	0,50	0,0040	0,0060	0,0080	0,010	0,012	0,016	0,020	0,024	0,028	0,032	0,040	0,050	50 (41 – 60)	
TS1	A	1,0	0,020	0,030	0,040	0,050	0,060	0,080	0,10	0,12	0,13	0,15	0,17	0,19	250 (150 – 355)	
TP1	A	1,0	0,020	0,030	0,040	0,050	0,060	0,080	0,10	0,12	0,13	0,15	0,17	0,19	250 (150 – 355)	
GR1	A	1,0	0,020	0,030	0,040	0,050	0,060	0,080	0,10	0,12	0,13	0,15	0,17	0,19	500 (405 – 600)	

For cutting data recalculations, see page 411-418.

SMG = Seco material group

Coolant = A=air D=dry E=emulsion M=mist spray

v_c = m/min

f_z = mm

a_p (mm)/DC (mm)= factor

All cutting data are target values

Cutting data – JS553 Side milling

SMG		a _g /DC	a _p /DC	f _z												v _c
				2	3	4	5	6	8	10	12	14	16	20	25	
P1	M/A/D/E	0,40	1,0	0,020	0,030	0,040	0,050	0,060	0,080	0,10	0,12	0,13	0,15	0,17	0,19	235 (205 – 265)
P2	M/A/D/E	0,40	1,0	0,020	0,030	0,040	0,050	0,060	0,080	0,10	0,12	0,13	0,15	0,17	0,19	230 (200 – 260)
P3	M/A/D/E	0,40	1,0	0,019	0,028	0,038	0,048	0,055	0,075	0,095	0,11	0,13	0,14	0,16	0,18	200 (175 – 225)
P4	M/A/D/E	0,40	1,0	0,019	0,028	0,038	0,046	0,055	0,075	0,095	0,11	0,13	0,14	0,16	0,18	175 (155 – 200)
P5	M/A/D/E	0,40	1,0	0,018	0,028	0,036	0,046	0,055	0,075	0,090	0,11	0,12	0,13	0,16	0,18	165 (120 – 190)
P6	M/A/D/E	0,40	1,0	0,018	0,028	0,036	0,046	0,055	0,075	0,090	0,11	0,12	0,13	0,15	0,17	185 (135 – 215)
P7	M/A/D/E	0,40	1,0	0,018	0,028	0,036	0,046	0,055	0,075	0,090	0,11	0,12	0,13	0,15	0,17	175 (125 – 200)
P8	M/A/D/E	0,40	1,0	0,019	0,028	0,038	0,048	0,055	0,075	0,095	0,11	0,13	0,14	0,16	0,18	165 (120 – 190)
P11	M/A/D/E	0,40	1,0	0,018	0,028	0,036	0,046	0,055	0,075	0,090	0,11	0,12	0,13	0,15	0,17	170 (125 – 195)
P12	M/A/D/E	0,40	0,80	0,010	0,015	0,020	0,026	0,030	0,040	0,050	0,060	0,070	0,075	0,085	0,10	115 (85 – 135)
M1	E	0,40	1,0	0,012	0,018	0,024	0,030	0,036	0,048	0,060	0,070	0,080	0,090	0,10	0,12	115 (100 – 130)
M2	E	0,40	1,0	0,011	0,017	0,022	0,028	0,034	0,044	0,055	0,065	0,075	0,080	0,095	0,11	95 (85 – 110)
M3	E	0,40	1,0	0,010	0,015	0,020	0,026	0,030	0,040	0,050	0,060	0,070	0,075	0,085	0,10	60 (48 – 70)
M4	E	0,40	0,70	0,0090	0,013	0,018	0,022	0,026	0,036	0,044	0,055	0,060	0,065	0,075	0,085	46 (37 – 55)
M5	E	0,40	0,70	0,0090	0,013	0,018	0,022	0,026	0,036	0,044	0,055	0,060	0,065	0,075	0,085	39 (31 – 46)
K1	E	0,40	1,2	0,016	0,024	0,032	0,040	0,048	0,065	0,080	0,095	0,11	0,12	0,14	0,16	190 (165 – 215)
K2	E	0,40	1,2	0,015	0,022	0,030	0,038	0,044	0,060	0,075	0,090	0,10	0,11	0,13	0,14	165 (145 – 185)
K3	E	0,40	1,2	0,015	0,022	0,030	0,038	0,044	0,060	0,075	0,090	0,10	0,11	0,13	0,14	140 (125 – 160)
K4	E	0,40	1,2	0,015	0,022	0,030	0,038	0,044	0,060	0,075	0,090	0,10	0,11	0,13	0,14	135 (120 – 150)
K5	E	0,40	1,1	0,016	0,024	0,032	0,040	0,048	0,065	0,080	0,095	0,11	0,12	0,14	0,16	160 (135 – 180)
K6	E	0,40	1,1	0,018	0,028	0,036	0,046	0,055	0,070	0,090	0,11	0,12	0,13	0,15	0,17	230 (195 – 260)
K7	E	0,40	1,1	0,016	0,024	0,032	0,040	0,048	0,065	0,080	0,095	0,11	0,12	0,14	0,16	205 (175 – 235)
N1	E	0,50	1,0	0,016	0,024	0,032	0,040	0,048	0,065	0,080	0,095	0,11	0,12	0,14	0,15	690 (580 – 810)
N2	E	0,50	1,0	0,016	0,024	0,032	0,040	0,048	0,065	0,080	0,095	0,11	0,12	0,14	0,15	445 (370 – 520)
N3	E	0,50	1,0	0,016	0,024	0,032	0,040	0,048	0,065	0,080	0,095	0,11	0,12	0,14	0,15	300 (250 – 345)
N11	E	0,50	1,1	0,016	0,024	0,032	0,040	0,048	0,065	0,080	0,095	0,11	0,12	0,13	0,15	335 (280 – 390)
S1	E	0,15	0,50	0,017	0,026	0,034	0,044	0,050	0,070	0,085	0,10	0,12	0,13	0,15	0,17	50 (39 – 65)
S2	E	0,15	0,50	0,017	0,026	0,034	0,044	0,050	0,070	0,085	0,10	0,12	0,13	0,15	0,17	42 (31 – 50)
S3	E	0,15	0,50	0,016	0,024	0,032	0,040	0,048	0,065	0,080	0,095	0,11	0,12	0,14	0,15	33 (20 – 46)
S11	E	0,40	1,0	0,010	0,015	0,020	0,024	0,030	0,040	0,050	0,060	0,070	0,080	0,10	0,12	115 (80 – 145)
S12	E	0,40	1,0	0,010	0,015	0,020	0,024	0,030	0,040	0,050	0,060	0,070	0,080	0,10	0,12	90 (65 – 115)
S13	E	0,40	0,90	0,010	0,015	0,020	0,024	0,030	0,040	0,050	0,060	0,070	0,080	0,090	0,10	70 (49 – 90)
H5	M/A/D	0,20	1,1	0,013	0,020	0,026	0,032	0,040	0,050	0,065	0,075	0,085	0,095	0,11	0,12	60 (48 – 75)
H8	M/A/D	0,20	0,90	0,010	0,015	0,020	0,024	0,030	0,040	0,050	0,060	0,065	0,075	0,085	0,095	65 (50 – 75)
H21	M/A/D	0,20	0,90	0,010	0,015	0,020	0,024	0,030	0,040	0,050	0,060	0,065	0,075	0,085	0,095	65 (50 – 75)
H31	M/A/D	0,20	0,90	0,0085	0,013	0,017	0,022	0,026	0,034	0,044	0,050	0,060	0,065	0,075	0,085	49 (39 – 60)
TS1	A	0,50	1,2	0,020	0,030	0,040	0,050	0,060	0,080	0,10	0,12	0,13	0,15	0,17	0,19	300 (180 – 420)
TP1	A	0,50	1,2	0,020	0,030	0,040	0,050	0,060	0,080	0,10	0,12	0,13	0,15	0,17	0,19	300 (180 – 420)
GR1	A	0,50	1,2	0,020	0,030	0,040	0,050	0,060	0,080	0,10	0,12	0,13	0,15	0,17	0,19	600 (480 – 720)

For cutting data recalculations, see page 411-418.

SMG = Seco material group

Coolant = A=air D=dry E=emulsion M=mist spray

v_c = m/min

f_z = mm

a_p (mm)/DC (mm) = factor

a_g (mm)/DC (mm) = factor

All cutting data are target values

JS554 – High performance – Universal – Square – 4 Flutes – Cylindrical – Chamfer



Tolerances:
 DMM=h5
 DC=e7
 Regrind possible if DC is ≥Ø6

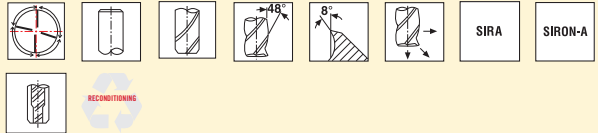
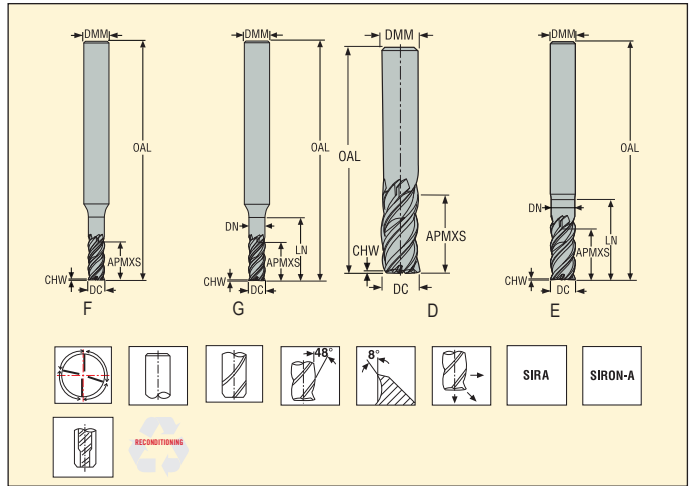

Ordering and Product No.	Designation	Length index	Tool shape	Dimensions in mm							PCE/DC	Cylindrical
				DC	DMM	APMXS	OAL	LN	DN	CHW		
02733455	554030Z4.0-SIRON-A	2	F	3,0	6	7	50	9	3,0	0,035	4	■
03029956	JS554030G2C.0Z4-SIRA	2	G	3,0	6	8	57	10	2,85	0,035	4	■
02733459	554040Z4.0-SIRON-A	2	F	4,0	6	10	55	12	4,0	0,045	4	■
03029957	JS554040G2C.0Z4-SIRA	2	G	4,0	6	10	57	13	3,8	0,045	4	■
02733813	554050Z4.0-SIRON-A	2	F	5,0	6	12	55	14	5,0	0,055	4	■
03029958	JS554050G2C.0Z4-SIRA	2	G	5,0	6	12	57	16	4,75	0,055	4	■
02679503	554060Z4.0-SIRON-A	2	D	6,0	6	14	55	-	-	0,075	4	■
03029959	JS554060E2C.0Z4-SIRA	2	E	6,0	6	14	57	18	5,7	0,075	4	■
02679512	554080Z4.0-SIRON-A	2	D	8,0	8	18	60	-	-	0,1	4	■
03029961	JS554080E2C.0Z4-SIRA	2	E	8,0	8	18	63	25	7,6	0,1	4	■
02679537	554100Z4.0-SIRON-A	2	D	10,0	10	22	70	-	-	0,125	4	■
03029963	JS554100E2C.0Z4-SIRA	2	E	10,0	10	22	72	29	9,5	0,125	4	■
02679548	554120Z4.0-SIRON-A	2	D	12,0	12	26	80	-	-	0,15	4	■
03029966	JS554120E2C.0Z4-SIRA	2	E	12,0	12	26	83	35	11,4	0,15	4	■
02679560	554160Z4.0-SIRON-A	2	D	16,0	16	34	90	-	-	0,2	4	■
03029970	JS554160E2C.0Z4-SIRA	2	E	16,0	16	34	92	42	15,2	0,2	4	■
02679566	554200Z4.0-SIRON-A	2	D	20,0	20	42	100	-	-	0,25	4	■
03029972	JS554200E2C.0Z4-SIRA	2	E	20,0	20	42	109	54	19,0	0,25	4	■
02679573	554250Z4.0-SIRON-A	2	D	25,0	25	52	125	-	-	0,3	4	■
02733818	554L030Z4.0-SIRON-A	3	F	3,0	6	12	55	14	3,0	0,035	4	■
02733823	554L040Z4.0-SIRON-A	3	F	4,0	6	16	60	18	4,0	0,045	4	■
02733825	554L050Z4.0-SIRON-A	3	F	5,0	6	20	65	22	5,0	0,055	4	■
02733828	554L060Z4.0-SIRON-A	3	D	6,0	6	23	65	-	-	0,075	4	■
02733830	554L080Z4.0-SIRON-A	3	D	8,0	8	32	75	-	-	0,1	4	■
02733832	554L100Z4.0-SIRON-A	3	D	10,0	10	40	85	-	-	0,125	4	■
02733834	554L120Z4.0-SIRON-A	3	D	12,0	12	45	100	-	-	0,15	4	■
02733836	554L160Z4.0-SIRON-A	3	D	16,0	16	55	115	-	-	0,2	4	■
02733838	554L200Z4.0-SIRON-A	3	D	20,0	20	65	125	-	-	0,25	4	■
02733841	554L250Z4.0-SIRON-A	3	D	25,0	25	85	150	-	-	0,3	4	■

■ Stock standard. Subject to change refer to current price- and stock-list

JS554 – High performance – Universal – Square – 4 Flutes – Cylindrical – Corner radius



Tolerances:
 DMM= h5
 DC= e7
 RE= ±0,02 mm
 Regrind possible if DC is ≥Ø6

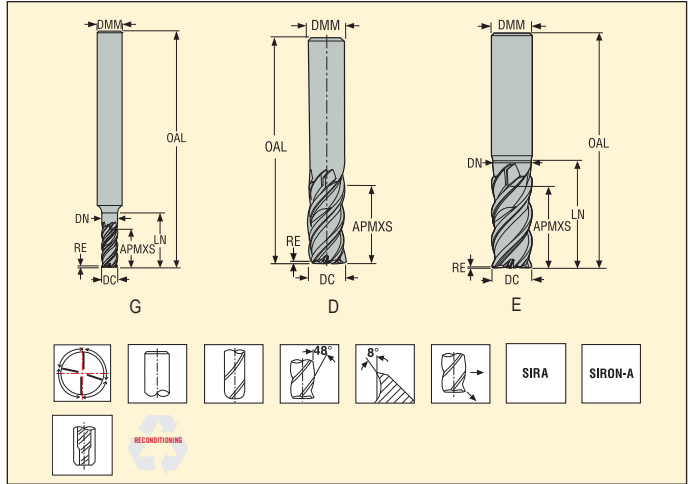

Ordering and Product No.	Designation	Length index	Tool shape	Dimensions in mm						PCE/DC	Cylindrical	
				DC	DMM	APMXS	OAL	LN	DN			RE
02881697	JS554030G2R015.0Z4-SIRA	2	G	3,0	6	7	57	10	2,85	0,15	4	■
02881698	JS554040G2R020.0Z4-SIRA	2	G	4,0	6	10	57	13	3,8	0,2	4	■
02881699	JS554050G2R020.0Z4-SIRA	2	G	5,0	6	12	57	16	4,75	0,2	4	■
02679507	554060R020Z4.0-SIRON-A	2	D	6,0	6	14	55	–	–	0,2	4	■
03029960	JS554060E2R020.0Z4-SIRA	2	E	6,0	6	14	57	18	5,7	0,2	4	■
02881700	JS554060E2R050.0Z4-SIRA	2	E	6,0	6	14	57	18	5,7	0,5	4	■
03029948	JS554060E2R100.0Z4-SIRA	2	E	6,0	6	14	57	18	5,7	1,0	4	■
02679514	554080R050Z4.0-SIRON-A	2	D	8,0	8	18	60	–	–	0,5	4	■
03029962	JS554080E2R050.0Z4-SIRA	2	E	8,0	8	18	63	25	7,6	0,5	4	■
02881701	JS554080E2R100.0Z4-SIRA	2	E	8,0	8	18	63	25	7,6	1,0	4	■
02679540	554100R050Z4.0-SIRON-A	2	D	10,0	10	22	70	–	–	0,5	4	■
03029964	JS554100E2R050.0Z4-SIRA	2	E	10,0	10	22	72	29	9,5	0,5	4	■
02679544	554100R100Z4.0-SIRON-A	2	D	10,0	10	22	70	–	–	1,0	4	■
03029965	JS554100E2R100.0Z4-SIRA	2	E	10,0	10	22	72	29	9,5	1,0	4	■
02881702	JS554100E2R200.0Z4-SIRA	2	E	10,0	10	22	72	29	9,5	2,0	4	■
03029949	JS554100E2R250.0Z4-SIRA	2	E	10,0	10	22	72	29	9,5	2,5	4	■
02679552	554120R050Z4.0-SIRON-A	2	D	12,0	12	26	80	–	–	0,5	4	■
03029968	JS554120E2R050.0Z4-SIRA	2	E	12,0	12	26	83	35	11,4	0,5	4	■
02679557	554120R100Z4.0-SIRON-A	2	D	12,0	12	26	80	–	–	1,0	4	■
03029969	JS554120E2R100.0Z4-SIRA	2	E	12,0	12	26	83	35	11,4	1,0	4	■
02881703	JS554120E2R200.0Z4-SIRA	2	E	12,0	12	26	83	35	11,4	2,0	4	■
02881704	JS554120E2R250.0Z4-SIRA	2	E	12,0	12	26	83	35	11,4	2,5	4	■
03029950	JS554120E2R300.0Z4-SIRA	2	E	12,0	12	26	83	35	11,4	3,0	4	■
02679562	554160R050Z4.0-SIRON-A	2	D	16,0	16	34	90	–	–	0,5	4	■
03029971	JS554160E2R050.0Z4-SIRA	2	E	16,0	16	34	92	42	15,2	0,5	4	■
02679564	554160R100Z4.0-SIRON-A	2	D	16,0	16	34	90	–	–	1,0	4	■
02810437	554160R200Z4.0-SIRON-A	2	D	16,0	16	34	90	–	–	2,0	4	■
02810439	554160R310Z4.0-SIRON-A	2	D	16,0	16	34	90	–	–	3,1	4	■
02810441	554160R400Z4.0-SIRON-A	2	D	16,0	16	34	90	–	–	4,0	4	■
03093685	JS554160E2R600.0Z4-SIRA	2	E	16,0	16	34	92	42	15,2	6,0	4	■
02679568	554200R050Z4.0-SIRON-A	2	D	20,0	20	42	100	–	–	0,5	4	■
02679571	554200R100Z4.0-SIRON-A	2	D	20,0	20	42	100	–	–	1,0	4	■
02881705	JS554200E2R200.0Z4-SIRA	2	E	20,0	20	42	110	54	19,0	2,0	4	■
02810443	554200R250Z4.0-SIRON-A	2	D	20,0	20	42	100	–	–	2,5	4	■
02810445	554200R310Z4.0-SIRON-A	2	D	20,0	20	42	100	–	–	3,1	4	■
02810447	554200R400Z4.0-SIRON-A	2	D	20,0	20	42	100	–	–	4,0	4	■
03029951	JS554200E2R600.0Z4-SIRA	2	E	20,0	20	42	109	54	19,0	6,0	4	■
02679575	554250R050Z4.0-SIRON-A	2	D	25,0	25	52	125	–	–	0,5	4	■
02679577	554250R100Z4.0-SIRON-A	2	D	25,0	25	52	125	–	–	1,0	4	■

■ Stock standard. Subject to change refer to current price- and stock-list

JS554 – High performance – Universal – Square – 4 Flutes – Weldon – Chamfer



Tolerances:
 DMM=h5
 DC=e7
 Regrind possible if DC is ≥Ø6

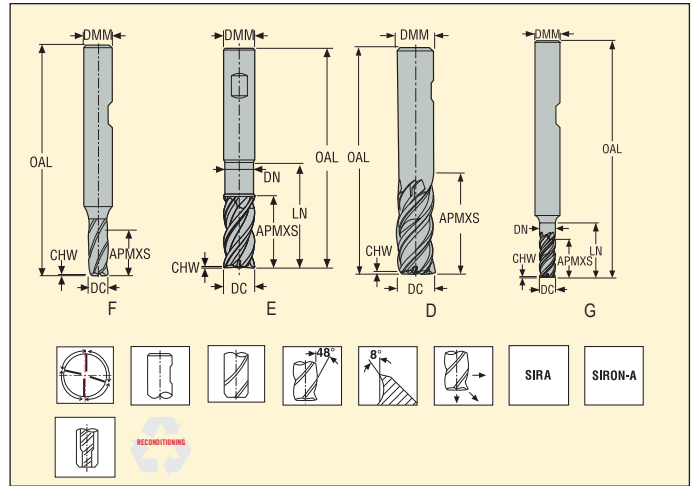

Ordering and Product No.	Designation	Length index	Tool shape	Dimensions in mm							PCEDC	Weldon
				DC	DMM	APMXS	OAL	LN	DN	CHW		
02733450	554030Z4.3-SIRON-A	2	F	3,0	6	7	50	9	3,0	0,035	4	■
03029973	JS554030G2C.3Z4-SIRA	2	G	3,0	6	8	57	10	2,85	0,035	4	□
02733456	554040Z4.3-SIRON-A	2	F	4,0	6	10	55	12	4,0	0,045	4	■
03029974	JS554040G2C.3Z4-SIRA	2	G	4,0	6	10	57	13	3,8	0,045	4	□
02733461	554050Z4.3-SIRON-A	2	F	5,0	6	12	55	14	5,0	0,055	4	■
03029975	JS554050G2C.3Z4-SIRA	2	G	5,0	6	12	57	16	4,75	0,055	4	□
02679502	554060Z4.3-SIRON-A	2	D	6,0	6	14	55	-	-	0,075	4	■
03029976	JS554060E2C.3Z4-SIRA	2	E	6,0	6	14	57	18	5,7	0,075	4	□
02679511	554080Z4.3-SIRON-A	2	D	8,0	8	18	60	-	-	0,1	4	■
03029978	JS554080E2C.3Z4-SIRA	2	E	8,0	8	18	63	25	7,6	0,1	4	□
02679535	554100Z4.3-SIRON-A	2	D	10,0	10	22	70	-	-	0,125	4	■
03029980	JS554100E2C.3Z4-SIRA	2	E	10,0	10	22	72	29	9,5	0,125	4	□
02679547	554120Z4.3-SIRON-A	2	D	12,0	12	26	80	-	-	0,15	4	■
03029983	JS554120E2C.3Z4-SIRA	2	E	12,0	12	26	83	35	11,4	0,15	4	□
02679559	554160Z4.3-SIRON-A	2	D	16,0	16	34	90	-	-	0,2	4	■
03029986	JS554160E2C.3Z4-SIRA	2	E	16,0	16	34	92	42	15,2	0,2	4	□
02679565	554200Z4.3-SIRON-A	2	D	20,0	20	42	100	-	-	0,25	4	■
03029988	JS554200E2C.3Z4-SIRA	2	E	20,0	20	42	109	54	19,0	0,25	4	□
02679572	554250Z4.3-SIRON-A	2	D	25,0	25	52	125	-	-	0,3	4	■
02733817	554L030Z4.3-SIRON-A	3	F	3,0	6	12	55	14	3,0	0,035	4	■
02733820	554L040Z4.3-SIRON-A	3	F	4,0	6	16	60	18	4,0	0,045	4	■
02733824	554L050Z4.3-SIRON-A	3	F	5,0	6	20	65	22	5,0	0,055	4	■
02733827	554L060Z4.3-SIRON-A	3	D	6,0	6	23	65	-	-	0,075	4	■
02733829	554L080Z4.3-SIRON-A	3	D	8,0	8	32	75	-	-	0,1	4	■
02733831	554L100Z4.3-SIRON-A	3	D	10,0	10	40	85	-	-	0,125	4	■
02733833	554L120Z4.3-SIRON-A	3	D	12,0	12	45	100	-	-	0,15	4	■
02733835	554L160Z4.3-SIRON-A	3	D	16,0	16	55	115	-	-	0,2	4	■
02733837	554L200Z4.3-SIRON-A	3	D	20,0	20	65	125	-	-	0,25	4	■
02733839	554L250Z4.3-SIRON-A	3	D	25,0	25	85	150	-	-	0,3	4	■

■ Stock standard. Subject to change refer to current price- and stock-list □ Weldon available, delivery time is 3 days.

JS554 - High performance - Universal - Square - 4 Flutes - Weldon - Corner radius



Tolerances:
 DMM= h5
 DC= e7
 RE= ±0,02 mm
 Regrind possible if DC is ≥Ø6

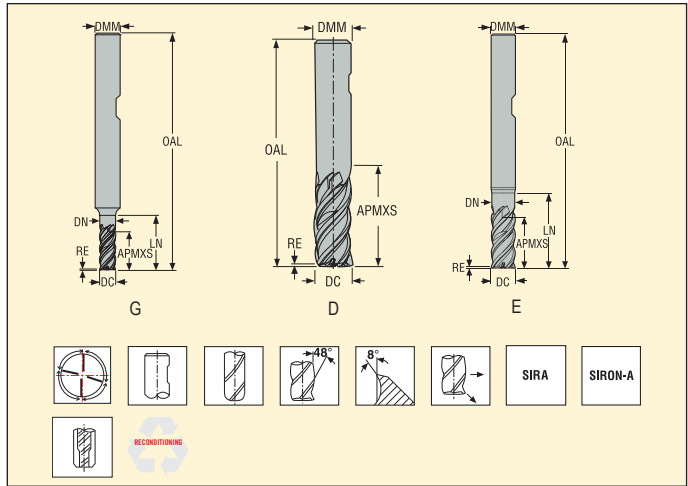

Ordering and Product No.	Designation	Length index	Tool shape	Dimensions in mm							PCEDC	Weldon
				DC	DMM	APMXS	OAL	LN	DN	RE		
02881706	JS554030G2R015.3Z4-SIRA	2	G	3,0	6	7	57	10	2,85	0,15	4	□
02881946	JS554040G2R020.3Z4-SIRA	2	G	4,0	6	10	57	13	3,8	0,2	4	□
02881708	JS554050G2R020.3Z4-SIRA	2	G	5,0	6	12	57	16	4,75	0,2	4	□
02679506	554060R020Z4.3-SIRON-A	2	D	6,0	6	14	55	-	-	0,2	4	■
03029977	JS554060E2R020.3Z4-SIRA	2	E	6,0	6	14	57	18	5,7	0,2	4	□
02881709	JS554060E2R050.3Z4-SIRA	2	E	6,0	6	14	57	18	5,7	0,5	4	□
03029952	JS554060E2R100.3Z4-SIRA	2	E	6,0	6	14	57	18	5,7	1,0	4	□
02679513	554080R050Z4.3-SIRON-A	2	D	8,0	8	18	60	-	-	0,5	4	■
03029979	JS554080E2R050.3Z4-SIRA	2	E	8,0	8	18	63	25	7,6	0,5	4	□
02881710	JS554080E2R100.3Z4-SIRA	2	E	8,0	8	18	63	25	7,6	1,0	4	□
02679539	554100R050Z4.3-SIRON-A	2	D	10,0	10	22	70	-	-	0,5	4	■
03029981	JS554100E2R050.3Z4-SIRA	2	E	10,0	10	22	72	29	9,5	0,5	4	□
02679542	554100R100Z4.3-SIRON-A	2	D	10,0	10	22	70	-	-	1,0	4	■
03029982	JS554100E2R100.3Z4-SIRA	2	E	10,0	10	22	72	29	9,5	1,0	4	□
02881711	JS554100E2R200.3Z4-SIRA	2	E	10,0	10	22	72	29	9,5	2,0	4	□
03029953	JS554100E2R250.3Z4-SIRA	2	E	10,0	10	22	72	29	9,5	2,5	4	□
02679549	554120R050Z4.3-SIRON-A	2	D	12,0	12	26	80	-	-	0,5	4	■
03029984	JS554120E2R050.3Z4-SIRA	2	E	12,0	12	26	83	35	11,4	0,5	4	■
02679554	554120R100Z4.3-SIRON-A	2	D	12,0	12	26	80	-	-	1,0	4	■
03029985	JS554120E2R100.3Z4-SIRA	2	E	12,0	12	26	83	35	11,4	1,0	4	□
02881712	JS554120E2R200.3Z4-SIRA	2	E	12,0	12	26	83	35	11,4	2,0	4	□
02881713	JS554120E2R250.3Z4-SIRA	2	E	12,0	12	26	83	35	11,4	2,5	4	□
03029954	JS554120E2R300.3Z4-SIRA	2	E	12,0	12	26	83	35	11,4	3,0	4	□
02679561	554160R050Z4.3-SIRON-A	2	D	16,0	16	34	90	-	-	0,5	4	■
03029987	JS554160E2R050.3Z4-SIRA	2	E	16,0	16	34	92	42	15,2	0,5	4	□
02679563	554160R100Z4.3-SIRON-A	2	D	16,0	16	34	90	-	-	1,0	4	■
02810436	554160R200Z4.3-SIRON-A	2	D	16,0	16	34	90	-	-	2,0	4	■
02810438	554160R310Z4.3-SIRON-A	2	D	16,0	16	34	90	-	-	3,1	4	■
02810440	554160R400Z4.3-SIRON-A	2	D	16,0	16	34	90	-	-	4,0	4	■
03093687	JS554160E2R600.3Z4-SIRA	2	E	16,0	16	34	92	42	15,2	6,0	4	□
02679567	554200R050Z4.3-SIRON-A	2	D	20,0	20	42	100	-	-	0,5	4	■
02679570	554200R100Z4.3-SIRON-A	2	D	20,0	20	42	100	-	-	1,0	4	■
02881714	JS554200E2R200.3Z4-SIRA	2	E	20,0	20	42	110	54	19,0	2,0	4	□
02810442	554200R250Z4.3-SIRON-A	2	D	20,0	20	42	100	-	-	2,5	4	■
02810444	554200R310Z4.3-SIRON-A	2	D	20,0	20	42	100	-	-	3,1	4	■
02810446	554200R400Z4.3-SIRON-A	2	D	20,0	20	42	100	-	-	4,0	4	■
03029955	JS554200E2R600.3Z4-SIRA	2	E	20,0	20	42	109	54	19,0	6,0	4	□
02679574	554250R050Z4.3-SIRON-A	2	D	25,0	25	52	125	-	-	0,5	4	■
02679576	554250R100Z4.3-SIRON-A	2	D	25,0	25	52	125	-	-	1,0	4	■

■ Stock standard. Subject to change refer to current price- and stock-list □ Weldon available, delivery time is 3 days.

Cutting data – JS554 Slot milling

SMG		a _p /DC	f _z											v _c
			3	4	5	6	8	10	12	16	20	25		
P1	M/A/D/E	1.0	0,018	0,024	0,030	0,036	0,048	0,060	0,070	0,095	0,12	0,15	195 (165 – 220)	
P2	M/A/D/E	1.0	0,018	0,024	0,030	0,036	0,048	0,060	0,070	0,095	0,12	0,15	190 (160 – 215)	
P3	M/A/D/E	1.0	0,018	0,024	0,030	0,036	0,048	0,060	0,070	0,095	0,12	0,15	165 (140 – 185)	
P4	M/A/D/E	1.0	0,018	0,024	0,030	0,036	0,048	0,060	0,070	0,095	0,12	0,15	145 (125 – 165)	
P5	M/A/D/E	1.0	0,018	0,024	0,030	0,036	0,048	0,060	0,070	0,095	0,12	0,15	135 (115 – 155)	
P6	M/A/D/E	1.0	0,018	0,024	0,030	0,036	0,048	0,060	0,070	0,095	0,12	0,15	155 (130 – 175)	
P7	M/A/D/E	1.0	0,018	0,024	0,030	0,036	0,048	0,060	0,070	0,095	0,12	0,15	145 (125 – 165)	
P8	M/A/D/E	1.0	0,018	0,024	0,030	0,036	0,048	0,060	0,070	0,095	0,12	0,15	135 (115 – 155)	
P11	M/A/D/E	1.0	0,018	0,024	0,030	0,036	0,048	0,060	0,070	0,095	0,12	0,15	140 (120 – 160)	
P12	M/A/D/E	0.80	0,015	0,019	0,024	0,030	0,038	0,048	0,060	0,075	0,085	0,095	85 (75 – 100)	
M1	E	0.80	0,012	0,016	0,020	0,024	0,032	0,040	0,048	0,065	0,080	0,10	95 (85 – 110)	
M2	E	0.80	0,012	0,016	0,020	0,024	0,032	0,040	0,048	0,065	0,080	0,10	80 (70 – 90)	
M3	E	0.60	0,0095	0,013	0,016	0,019	0,026	0,032	0,038	0,050	0,065	0,080	50 (40 – 60)	
M4	E	0.45	0,0095	0,013	0,016	0,019	0,026	0,032	0,038	0,050	0,065	0,080	37 (30 – 45)	
M5	E	0.45	0,0095	0,013	0,016	0,019	0,026	0,032	0,038	0,050	0,065	0,080	31 (25 – 37)	
K1	E	1.0	0,015	0,020	0,026	0,030	0,040	0,050	0,060	0,080	0,10	0,13	160 (140 – 180)	
K2	E	1.0	0,015	0,020	0,026	0,030	0,040	0,050	0,060	0,080	0,10	0,13	140 (120 – 155)	
K3	E	1.0	0,015	0,020	0,026	0,030	0,040	0,050	0,060	0,080	0,10	0,13	115 (105 – 130)	
K4	E	1.0	0,015	0,020	0,026	0,030	0,040	0,050	0,060	0,080	0,10	0,13	110 (100 – 125)	
K5	E	0.70	0,015	0,020	0,026	0,030	0,040	0,050	0,060	0,080	0,10	0,13	140 (120 – 160)	
K6	E	0.70	0,015	0,020	0,026	0,030	0,040	0,050	0,060	0,080	0,10	0,13	160 (140 – 180)	
K7	E	0.70	0,015	0,020	0,026	0,030	0,040	0,050	0,060	0,080	0,10	0,13	160 (140 – 180)	
N1	E	0.50	0,015	0,020	0,026	0,030	0,040	0,050	0,060	0,080	0,10	0,13	620 (520 – 730)	
N2	E	0.50	0,015	0,020	0,026	0,030	0,040	0,050	0,060	0,080	0,10	0,13	400 (335 – 465)	
N3	E	0.50	0,015	0,020	0,026	0,030	0,040	0,050	0,060	0,080	0,10	0,13	265 (225 – 310)	
N11	E	0.60	0,018	0,024	0,030	0,036	0,048	0,060	0,070	0,095	0,12	0,15	300 (250 – 350)	
S1	E	0.30	0,0095	0,013	0,016	0,019	0,026	0,032	0,038	0,050	0,065	0,080	40 (30 – 50)	
S2	E	0.30	0,0095	0,013	0,016	0,019	0,026	0,032	0,038	0,050	0,065	0,080	32 (24 – 40)	
S3	E	0.30	0,0095	0,013	0,016	0,019	0,026	0,032	0,038	0,050	0,065	0,080	25 (15 – 35)	
S11	E	0.50	0,012	0,016	0,020	0,024	0,032	0,040	0,050	0,065	0,080	0,10	85 (60 – 110)	
S12	E	0.50	0,012	0,016	0,020	0,024	0,032	0,040	0,050	0,065	0,080	0,10	65 (48 – 85)	
S13	E	0.45	0,012	0,016	0,020	0,024	0,032	0,040	0,050	0,065	0,080	0,10	50 (37 – 65)	
H5	M/A/D	0.45	0,0060	0,0080	0,010	0,012	0,016	0,020	0,024	0,032	0,040	0,050	50 (40 – 60)	
H8	M/A/D	0.40	0,0060	0,0080	0,010	0,012	0,016	0,020	0,024	0,032	0,040	0,050	50 (41 – 60)	
H11	M/A/D	0.45	0,0060	0,0080	0,010	0,012	0,016	0,020	0,024	0,032	0,040	0,050	65 (55 – 75)	
H12	M/A/D	0.70	0,0090	0,012	0,015	0,018	0,024	0,030	0,034	0,042	0,050	0,055	55 (49 – 65)	
H21	M/A/D	0.40	0,0060	0,0080	0,010	0,012	0,016	0,020	0,024	0,032	0,040	0,050	50 (41 – 60)	
TS1	A	0.70	0,030	0,040	0,050	0,060	0,080	0,10	0,12	0,15	0,17	0,19	250 (150 – 350)	
TP1	A	0.70	0,030	0,040	0,050	0,060	0,080	0,10	0,12	0,15	0,17	0,19	250 (150 – 350)	
GR1	A	0.80	0,030	0,040	0,050	0,060	0,080	0,10	0,12	0,15	0,17	0,19	500 (400 – 600)	

For cutting data recalculations, see page 411-418.

SMG = Seco material group

Coolant = A=air D=dry E=emulsion M=mist spray

f_z = m/min

f_z = mm

a_p (mm)/DC (mm)= factor

All cutting data are target values

Cutting data – JS554 Side milling roughing

SMG		a _e /DC	a _p /DC	f _z										v _c
				3	4	5	6	8	10	12	16	20	25	
P1	M/A/D/E	0,40	1,0	0,030	0,040	0,050	0,060	0,080	0,10	0,12	0,15	0,17	0,19	215 (185 – 245)
P2	M/A/D/E	0,40	1,0	0,030	0,040	0,050	0,060	0,080	0,10	0,12	0,15	0,17	0,19	210 (180 – 240)
P3	M/A/D/E	0,40	1,0	0,028	0,038	0,048	0,055	0,075	0,095	0,11	0,14	0,16	0,18	185 (155 – 210)
P4	M/A/D/E	0,40	1,0	0,028	0,038	0,046	0,055	0,075	0,095	0,11	0,14	0,16	0,18	160 (140 – 185)
P5	M/A/D/E	0,40	1,0	0,028	0,036	0,046	0,055	0,075	0,090	0,11	0,13	0,16	0,18	155 (135 – 180)
P6	M/A/D/E	0,40	1,0	0,028	0,036	0,046	0,055	0,075	0,090	0,11	0,13	0,15	0,17	175 (150 – 200)
P7	M/A/D/E	0,40	1,0	0,028	0,036	0,046	0,055	0,075	0,090	0,11	0,13	0,15	0,17	165 (140 – 190)
P8	M/A/D/E	0,40	1,0	0,028	0,038	0,048	0,055	0,075	0,095	0,11	0,14	0,16	0,18	155 (130 – 175)
P11	M/A/D/E	0,40	1,0	0,028	0,036	0,046	0,055	0,075	0,090	0,11	0,13	0,15	0,17	160 (140 – 185)
P12	M/A/D/E	0,40	0,80	0,015	0,020	0,026	0,030	0,040	0,050	0,060	0,075	0,085	0,10	110 (95 – 125)
M1	E	0,40	1,0	0,018	0,024	0,030	0,036	0,048	0,060	0,070	0,090	0,10	0,12	110 (95 – 125)
M2	E	0,40	1,0	0,017	0,022	0,028	0,034	0,044	0,055	0,065	0,080	0,095	0,11	90 (80 – 105)
M3	E	0,40	0,90	0,015	0,020	0,026	0,030	0,040	0,050	0,060	0,075	0,085	0,095	55 (45 – 70)
M4	E	0,40	0,70	0,013	0,018	0,022	0,026	0,036	0,044	0,055	0,065	0,075	0,085	44 (35 – 55)
M5	E	0,40	0,70	0,013	0,018	0,022	0,026	0,036	0,044	0,055	0,065	0,075	0,085	36 (29 – 44)
K1	E	0,40	1,2	0,024	0,032	0,040	0,048	0,065	0,080	0,095	0,12	0,14	0,16	180 (160 – 205)
K2	E	0,40	1,2	0,022	0,030	0,038	0,044	0,060	0,075	0,090	0,11	0,13	0,14	160 (140 – 180)
K3	E	0,40	1,2	0,022	0,030	0,038	0,044	0,060	0,075	0,090	0,11	0,13	0,14	135 (120 – 150)
K4	E	0,40	1,2	0,022	0,030	0,038	0,044	0,060	0,075	0,090	0,11	0,13	0,14	130 (110 – 145)
K5	E	0,40	1,0	0,024	0,032	0,040	0,048	0,065	0,080	0,095	0,12	0,14	0,16	160 (135 – 180)
K6	E	0,40	1,0	0,028	0,036	0,046	0,055	0,070	0,090	0,11	0,13	0,15	0,17	175 (155 – 195)
K7	E	0,40	1,0	0,024	0,032	0,040	0,048	0,065	0,080	0,095	0,12	0,14	0,16	180 (160 – 205)
N1	E	0,50	0,90	0,024	0,032	0,040	0,048	0,065	0,080	0,095	0,12	0,13	0,15	660 (550 – 770)
N2	E	0,50	0,90	0,024	0,032	0,040	0,048	0,065	0,080	0,095	0,12	0,13	0,15	425 (355 – 495)
N11	E	0,50	1,1	0,024	0,032	0,040	0,048	0,065	0,080	0,095	0,12	0,13	0,15	330 (275 – 385)
S11	E	0,40	0,70	0,015	0,020	0,024	0,030	0,040	0,050	0,060	0,080	0,10	0,12	105 (75 – 135)
S12	E	0,40	0,70	0,015	0,020	0,024	0,030	0,040	0,050	0,060	0,080	0,10	0,12	80 (55 – 105)
S13	E	0,40	0,60	0,015	0,020	0,024	0,030	0,040	0,050	0,060	0,080	0,090	0,10	60 (44 – 80)
H5	M/A/D	0,20	1,0	0,020	0,026	0,032	0,040	0,050	0,065	0,075	0,095	0,11	0,12	60 (48 – 70)
H8	M/A/D	0,20	0,90	0,015	0,020	0,024	0,030	0,040	0,050	0,060	0,075	0,085	0,095	65 (50 – 75)
H11	M/A/D	0,20	1,0	0,020	0,026	0,032	0,040	0,050	0,065	0,075	0,095	0,11	0,12	80 (65 – 90)
H12	M/A/D	0,40	0,70	0,0090	0,012	0,015	0,018	0,024	0,030	0,036	0,044	0,050	0,055	70 (60 – 80)
H21	M/A/D	0,20	0,90	0,015	0,020	0,024	0,030	0,040	0,050	0,060	0,075	0,085	0,095	65 (50 – 75)
TS1	A	0,50	1,0	0,030	0,040	0,050	0,060	0,080	0,10	0,12	0,15	0,17	0,19	295 (175 – 415)
TP1	A	0,50	1,0	0,030	0,040	0,050	0,060	0,080	0,10	0,12	0,15	0,17	0,19	295 (175 – 415)
GR1	A	0,50	1,0	0,030	0,040	0,050	0,060	0,080	0,10	0,12	0,15	0,17	0,19	590 (475 – 710)

For cutting data recalculations, see page 411-418.

SMG = Seco material group

Coolant = A=air D=dry E=emulsion M=mist spray

v_c = m/min

f_z = mm

a_p (mm)/DC (mm)= factor

a_e (mm)/DC (mm)= factor

All cutting data are target values

Advanced Roughing, what does it mean?

These CAM-based rough-machining, or dynamic milling, strategies are ones that centre on a cutting tool's arc of contact and its average chip load.

When reducing the arc of contact, the amount of heat generated during roughing operations is reduced. As the radial depth of cut decreases, so does a cutter's arc of contact. A smaller amount of contact results in less friction and, therefore, less heat between the tool's cutting edges and the workpiece it is machining. These lower machining temperatures, in turn, allow for increased cutting speeds shorter cycle times.

JS554-3C, JS564 and JS565 Cutter designs for advanced roughing machining methods

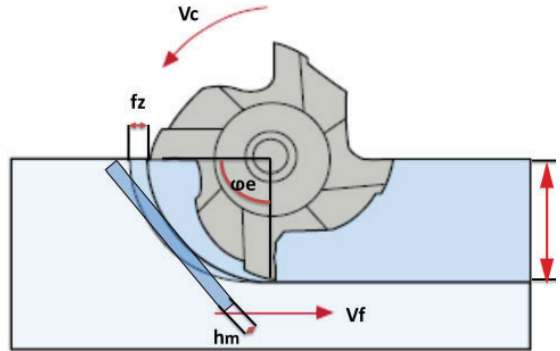

To cover a wide range of workpiece materials, Seco recently modified the geometries of its Jabro®-Solid² 560 line of cutters specifically for optimised rough-machining strategies.

Within the JS560 Series are longer length tools that the company determined work best for deep pocket and 3D shape roughing/dynamic milling.

When a steady arc of contact is maintained, these tools experience consistent and evenly distributed wear along their flutes and provide a long and predictable tool life.

JS554-3C, JS564 and JS565 applied in Advanced roughing

Today's CAM packages offer toolpath strategies specifically for inside/outside radii shapes where changing arcs of contact are common when using conventional toolpaths. These software packages automatically apply different feeds to control arc of contact and keep chip loads consistent.

In advanced roughing, to maintain arc of contact, CAM packages need to employ trochoidal machining and peel milling techniques when entering a radius.

When using an optimised roughing toolpath and maintaining consistent arc of contact, the cutter's radius can match that of the inside radius being cut without risk of cutter overload, grabbing or overcutting. This capability allows the JS554-3C, JS564 and JS565 to remove more stock in the roughing pass, thus reducing the amount of stock the finish pass has to cut – all of which translates to faster machining cycle times.

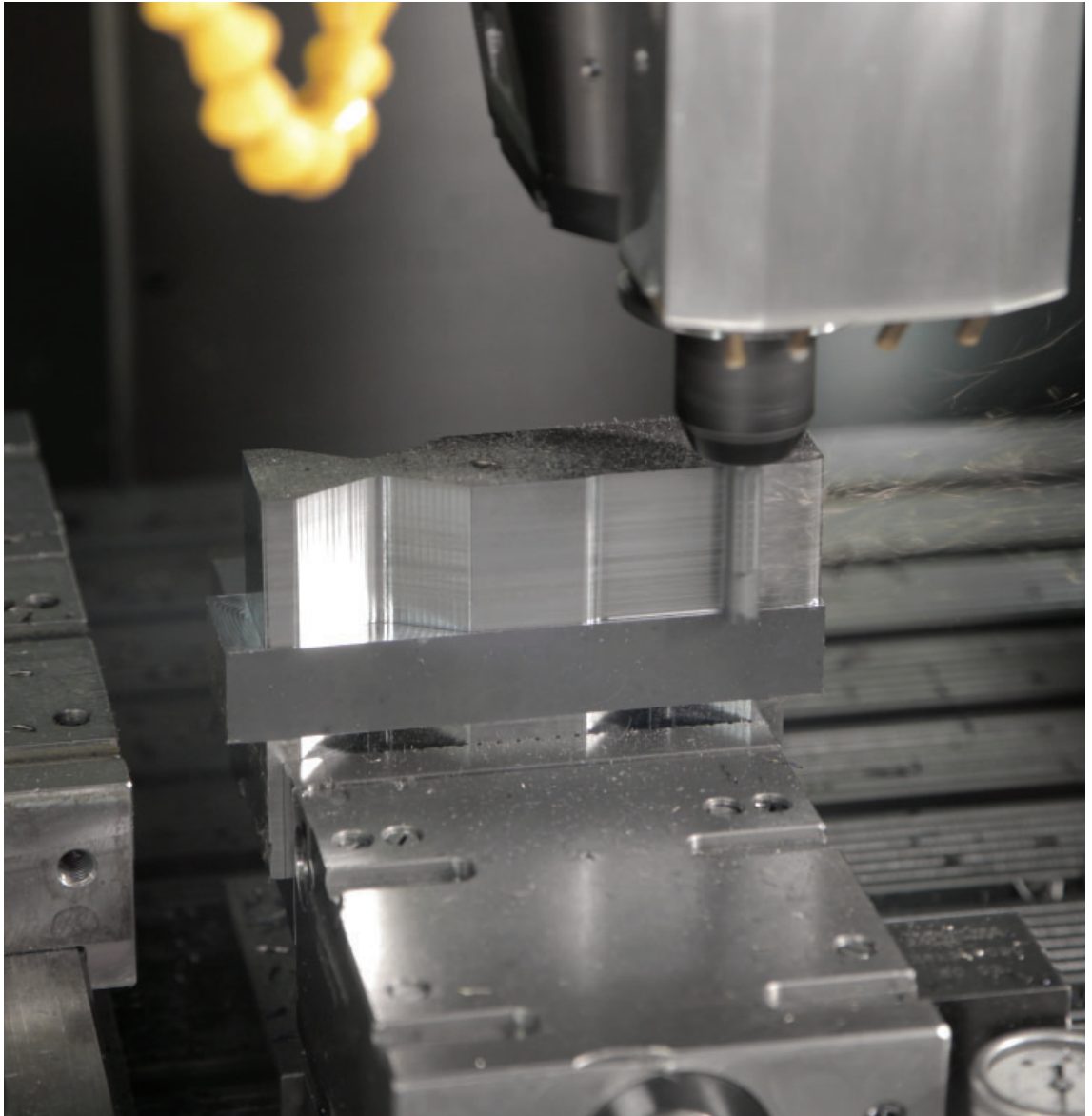

Cutting data – JS554 3C Advanced roughing

SMG		a _p /DC	a _p /DC	f _z							
				6	8	10	12	16	20	25	
P1	M/A/D/E	0,1	3,5	0,065	0,085	0,11	0,13	0,16	0,18	0,20	230 (205 – 255)
P2	M/A/D/E	0,1	3,5	0,065	0,090	0,11	0,13	0,16	0,19	0,22	215 (190 – 240)
P3	M/A/D/E	0,1	3,5	0,060	0,085	0,10	0,12	0,15	0,18	0,20	210 (180 – 235)
P4	M/A/D/E	0,1	3,5	0,060	0,080	0,10	0,12	0,15	0,17	0,20	195 (170 – 220)
P5	M/A/D/E	0,1	3,5	0,060	0,080	0,10	0,12	0,15	0,17	0,19	180 (130 – 210)
P6	M/A/D/E	0,1	3,5	0,060	0,080	0,10	0,12	0,15	0,17	0,19	205 (145 – 235)
P7	M/A/D/E	0,1	3,5	0,060	0,080	0,10	0,12	0,15	0,17	0,19	195 (140 – 220)
P8	M/A/D/E	0,1	3,5	0,060	0,085	0,10	0,12	0,15	0,18	0,20	180 (130 – 210)
P11	M/A/D/E	0,1	3,5	0,060	0,080	0,10	0,12	0,15	0,17	0,19	185 (135 – 215)
P12	M/A/D/E	0,1	3,5	0,034	0,044	0,055	0,065	0,080	0,095	0,11	125 (90 – 140)
M1	E	0,1	3,5	0,030	0,040	0,050	0,060	0,075	0,085	0,095	130 (115 – 145)
M2	E	0,1	3,5	0,028	0,036	0,046	0,055	0,065	0,075	0,085	105 (95 – 120)
M3	E	0,1	3,5	0,026	0,034	0,042	0,050	0,060	0,070	0,080	70 (55 – 80)
M4	E	0,1	3,5	0,022	0,030	0,036	0,044	0,055	0,060	0,070	50 (42 – 65)
M5	E	0,1	3,5	0,022	0,030	0,036	0,044	0,055	0,060	0,070	44 (35 – 50)
K1	E	0,1	3,5	0,048	0,065	0,080	0,095	0,12	0,14	0,15	205 (180 – 235)
K2	E	0,1	3,5	0,044	0,060	0,075	0,085	0,11	0,12	0,14	180 (160 – 205)
K3	E	0,1	3,5	0,044	0,060	0,075	0,085	0,11	0,12	0,14	155 (135 – 175)
K4	E	0,1	3,5	0,044	0,060	0,075	0,085	0,11	0,12	0,14	145 (130 – 165)
K5	E	0,1	3,5	0,048	0,065	0,080	0,095	0,12	0,14	0,15	180 (155 – 205)
K6	E	0,1	3,5	0,055	0,070	0,090	0,11	0,13	0,15	0,17	200 (175 – 230)
K7	E	0,1	3,5	0,048	0,065	0,080	0,095	0,12	0,14	0,15	205 (205 – 235)
N1	E	0,1	3,5	0,060	0,080	0,10	0,12	0,15	0,17	0,19	780 (650 – 910)
N2	E	0,1	3,5	0,060	0,080	0,10	0,12	0,15	0,17	0,19	500 (415 – 580)
N3	E	0,1	3,5	0,060	0,080	0,10	0,12	0,15	0,17	0,19	335 (280 – 390)
N11	E	0,1	3,5	0,060	0,080	0,10	0,12	0,15	0,17	0,19	390 (325 – 455)
S1	E	0,05	3,5	0,026	0,036	0,044	0,055	0,065	0,075	0,085	60 (44 – 75)
S2	E	0,05	3,5	0,026	0,036	0,044	0,055	0,065	0,075	0,085	47 (36 – 60)
S3	E	0,05	3,5	0,024	0,034	0,042	0,050	0,060	0,070	0,080	37 (22 – 50)
S11	E	0,05	3,5	0,036	0,048	0,060	0,070	0,090	0,10	0,12	115 (85 – 150)
S12	E	0,05	3,5	0,036	0,048	0,060	0,070	0,090	0,10	0,12	90 (65 – 115)
S13	E	0,05	3,5	0,032	0,042	0,055	0,060	0,080	0,090	0,10	70 (50 – 90)
H5	M/A/D	0,07	3,5	0,024	0,032	0,040	0,046	0,060	0,065	0,075	75 (60 – 90)
H8	M/A/D	0,07	3,5	0,018	0,024	0,030	0,036	0,044	0,050	0,055	80 (60 – 95)
H11	M/A/D	0,07	3,5	0,024	0,032	0,040	0,046	0,060	0,065	0,075	90 (65 – 105)
H12	M/A/D	0,07	3,5	0,019	0,026	0,032	0,038	0,048	0,055	0,060	80 (55 – 90)
H21	M/A/D	0,07	3,5	0,018	0,024	0,030	0,036	0,044	0,050	0,055	80 (60 – 95)

For cutting data recalculations, see page 411-418.

SMG = Seco material group

Coolant = A=air D=dry E=emulsion M=mist spray

v_c = m/min

f_z = mm

a_p (mm)/DC (mm)= factor

a_e (mm)/DC (mm)= factor

All cutting data are target values

Cutting data – JS564 Side milling advanced roughing

SMG		a _e /DC	a _p /DC	f _z									v _c
				4	5	6	8	10	12	16	20		
P1	E/M/A/D	0,15	2,5	0,042	0,055	0,065	0,085	0,11	0,13	0,16	0,18	305 (265 – 345)	
P2	E/M/A/D	0,15	2,5	0,044	0,055	0,065	0,085	0,11	0,13	0,16	0,18	295 (260 – 335)	
P3	E/M/A/D	0,15	2,5	0,040	0,050	0,060	0,080	0,10	0,12	0,15	0,17	260 (225 – 295)	
P4	E/M/A/D	0,15	2,5	0,040	0,050	0,060	0,080	0,10	0,12	0,15	0,17	230 (200 – 260)	
P5	E/M/A/D	0,15	2,5	0,040	0,050	0,060	0,080	0,10	0,12	0,15	0,17	215 (185 – 245)	
P6	E/M/A/D	0,15	2,5	0,040	0,050	0,060	0,080	0,10	0,12	0,15	0,17	240 (210 – 275)	
P7	E/M/A/D	0,15	2,5	0,040	0,050	0,060	0,080	0,10	0,12	0,15	0,17	230 (195 – 260)	
P8	E/M/A/D	0,15	2,5	0,042	0,050	0,060	0,085	0,10	0,12	0,15	0,18	215 (185 – 245)	
P11	E/M/A/D	0,15	2,5	0,040	0,050	0,060	0,080	0,10	0,12	0,15	0,17	220 (190 – 250)	
P12	E/M/A/D	0,15	2,0	0,024	0,030	0,036	0,048	0,060	0,070	0,090	0,10	145 (125 – 165)	
M1	E	0,15	2,5	0,040	0,050	0,060	0,080	0,10	0,12	0,15	0,17	200 (175 – 225)	
M2	E	0,15	2,5	0,036	0,046	0,055	0,075	0,090	0,11	0,13	0,15	165 (145 – 185)	
M3	E	0,10	2,5	0,040	0,050	0,060	0,080	0,10	0,12	0,15	0,17	130 (110 – 150)	
M4	E	0,10	2,5	0,040	0,050	0,060	0,080	0,10	0,12	0,15	0,17	130 (110 – 150)	
M5	E	0,10	2,5	0,040	0,050	0,060	0,080	0,10	0,12	0,15	0,17	110 (90 – 125)	
K1	E	0,15	2,5	0,044	0,055	0,065	0,090	0,11	0,13	0,16	0,19	260 (225 – 295)	
K2	E	0,15	2,5	0,040	0,050	0,060	0,080	0,10	0,12	0,15	0,17	230 (200 – 260)	
K3	E	0,15	2,5	0,040	0,050	0,060	0,080	0,10	0,12	0,15	0,17	195 (170 – 220)	
K4	E	0,15	2,5	0,040	0,050	0,060	0,080	0,10	0,12	0,15	0,17	185 (160 – 210)	
K5	E	0,15	2,5	0,036	0,044	0,055	0,070	0,090	0,11	0,13	0,15	115 (100 – 130)	
K6	E	0,15	2,5	0,040	0,050	0,060	0,080	0,10	0,12	0,15	0,17	165 (140 – 185)	
K7	E	0,15	2,5	0,036	0,044	0,055	0,070	0,090	0,11	0,13	0,15	145 (125 – 165)	
N1	E	0,15	2,5	0,040	0,050	0,060	0,080	0,10	0,12	0,15	0,17	700 (600 – 800)	
N2	E	0,15	2,5	0,040	0,050	0,060	0,080	0,10	0,12	0,15	0,17	450 (385 – 510)	
N3	E	0,10	2,5	0,040	0,050	0,060	0,080	0,10	0,12	0,15	0,17	500 (400 – 600)	
N11	E	0,15	2,5	0,040	0,050	0,060	0,080	0,10	0,12	0,15	0,17	350 (300 – 400)	
S1	E	0,030	2,5	0,028	0,036	0,042	0,055	0,070	0,085	0,10	0,12	60 (37 – 85)	
S2	E	0,030	2,5	0,028	0,036	0,042	0,055	0,070	0,085	0,10	0,12	50 (30 – 70)	
S3	E	0,030	2,5	0,026	0,032	0,038	0,050	0,065	0,075	0,095	0,11	43 (26 – 60)	
S11	E	0,080	2,5	0,028	0,034	0,042	0,055	0,070	0,085	0,10	0,12	160 (135 – 190)	
S12	E	0,080	2,5	0,028	0,034	0,042	0,055	0,070	0,085	0,10	0,12	125 (105 – 145)	
S13	E	0,080	2,5	0,028	0,034	0,042	0,055	0,070	0,085	0,10	0,12	125 (105 – 145)	
H8	M/A/D	0,050	2,5	0,024	0,028	0,034	0,046	0,060	0,070	0,085	0,10	155 (130 – 185)	
H21	M/A/D	0,050	2,5	0,024	0,028	0,034	0,046	0,060	0,070	0,085	0,10	155 (130 – 185)	
H31	M/A/D	0,050	2,5	0,020	0,024	0,030	0,040	0,050	0,060	0,075	0,085	120 (100 – 140)	

For cutting data recalculations, see page 411-418.

SMG = Seco material group

Coolant = A=air D=dry E=emulsion M=mist spray

v_c = m/min

f_z = mm

a_p (mm)/DC (mm)= factor

a_e (mm)/DC (mm)= factor

All cutting data are target values

JS565 – Advanced roughing – Universal – Square – 5 Flutes – Weldon – Chamfer



Tolerances:
 DMM= h5
 DC= e7
 PCEDC5= no chip splitters
 PCEDC5C= with chip splitters
 Regrind possible if DC is ≥ 08

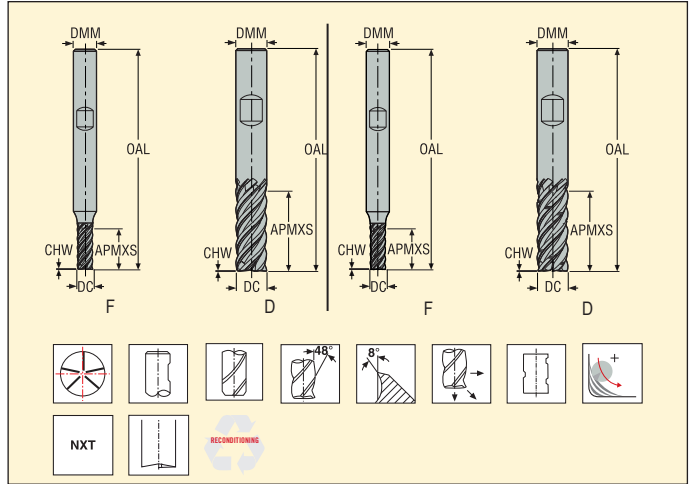

Ordering and Product No.	Designation	Length index	Tool shape	Chip splitters	Dimensions in mm					PCEDC	Weldon
					DC	DMM	APMXS	OAL	CHW		
03067392	JS565030F2C.3Z5-NXT	2	F	■	3,0	6	7,0	57	0,04	5	■
03067393	JS565040F2C.3Z5-NXT	2	F	■	4,0	6	10,0	57	0,05	5	■
03067394	JS565050F2C.3Z5-NXT	2	F	■	5,0	6	12,5	57	0,06	5	■
03067395	JS565060D2C.3Z5-NXT	2	D	■	6,0	6	15,0	57	0,075	5	■
03067396	JS565080D2C.3Z5-NXT	2	D	■	8,0	8	20,0	63	0,1	5	■
03067397	JS565100D2C.3Z5-NXT	2	D	■	10,0	10	25,0	72	0,125	5	■
03067398	JS565120D2C.3Z5-NXT	2	D	■	12,0	12	30,0	83	0,15	5	■
03067399	JS565160D2C.3Z5-NXT	2	D	■	16,0	16	40,0	99	0,2	5	■
03067400	JS565200D2C.3Z5-NXT	2	D	■	20,0	20	50,0	114	0,25	5	■
03067401	JS565030F2C.3Z5C-NXT	2	F	■	3,0	6	7,0	57	0,04	5	■
03067402	JS565040F2C.3Z5C-NXT	2	F	■	4,0	6	10,0	57	0,05	5	■
03067403	JS565050F2C.3Z5C-NXT	2	F	■	5,0	6	12,5	57	0,06	5	■
03067404	JS565060D2C.3Z5C-NXT	2	D	■	6,0	6	15,0	57	0,075	5	■
03067405	JS565080D2C.3Z5C-NXT	2	D	■	8,0	8	20,0	63	0,1	5	■
03067406	JS565100D2C.3Z5C-NXT	2	D	■	10,0	10	25,0	72	0,125	5	■
03067407	JS565120D2C.3Z5C-NXT	2	D	■	12,0	12	30,0	83	0,15	5	■
03067408	JS565160D2C.3Z5C-NXT	2	D	■	16,0	16	40,0	99	0,2	5	■
03067409	JS565200D2C.3Z5C-NXT	2	D	■	20,0	20	50,0	114	0,25	5	■
03067410	JS565060D3C.3Z5C-NXT	3	D	■	6,0	6	23,0	64	0,075	5	■
03067411	JS565080D3C.3Z5C-NXT	3	D	■	8,0	8	32,0	74	0,1	5	■
03067412	JS565100D3C.3Z5C-NXT	3	D	■	10,0	10	40,0	88	0,125	5	■
03067413	JS565120D3C.3Z5C-NXT	3	D	■	12,0	12	45,0	99	0,15	5	■
03067414	JS565160D3C.3Z5C-NXT	3	D	■	16,0	16	55,0	114	0,2	5	■
03067415	JS565200D3C.3Z5C-NXT	3	D	■	20,0	20	65,0	126	0,25	5	■

■ Stock standard. Subject to change refer to current price- and stock-list

Cutting data – JS565 Side milling advanced roughing

SMG		a _e /DC	a _p /DC	f _z								v _c
				4	5	6	8	10	12	16	20	
P1	E/M/A/D	0,10	2,5	0,050	0,065	0,075	0,10	0,13	0,15	0,19	0,22	325 (265 – 345)
P2	E/M/A/D	0,10	2,5	0,050	0,065	0,080	0,10	0,13	0,15	0,19	0,22	315 (260 – 335)
P3	E/M/A/D	0,10	2,5	0,048	0,060	0,075	0,10	0,12	0,14	0,18	0,20	280 (225 – 295)
P4	E/M/A/D	0,10	2,5	0,048	0,060	0,070	0,095	0,12	0,14	0,18	0,20	245 (200 – 260)
P5	E/M/A/D	0,10	2,5	0,048	0,060	0,070	0,095	0,12	0,14	0,18	0,20	230 (185 – 245)
P6	E/M/A/D	0,10	2,5	0,048	0,060	0,070	0,095	0,12	0,14	0,17	0,20	260 (210 – 275)
P7	E/M/A/D	0,10	2,5	0,048	0,060	0,070	0,095	0,12	0,14	0,17	0,20	245 (195 – 260)
P8	E/M/A/D	0,10	2,5	0,050	0,060	0,075	0,10	0,12	0,15	0,18	0,22	230 (185 – 245)
P11	E/M/A/D	0,10	2,5	0,048	0,060	0,070	0,095	0,12	0,14	0,17	0,20	235 (190 – 250)
P12	E/M/A/D	0,10	2,0	0,028	0,036	0,044	0,055	0,070	0,085	0,11	0,12	155 (125 – 165)
M1	E	0,10	2,5	0,048	0,060	0,070	0,095	0,12	0,14	0,18	0,20	210 (175 – 225)
M2	E	0,10	2,5	0,044	0,055	0,065	0,085	0,11	0,13	0,16	0,18	175 (145 – 185)
M3	E	0,10	2,5	0,040	0,050	0,060	0,080	0,10	0,12	0,15	0,17	130 (110 – 150)
M4	E	0,10	2,5	0,040	0,050	0,060	0,080	0,10	0,12	0,15	0,17	130 (110 – 150)
M5	E	0,10	2,5	0,040	0,050	0,060	0,080	0,10	0,12	0,15	0,17	110 (90 – 125)
K1	E	0,10	2,5	0,055	0,065	0,080	0,11	0,13	0,16	0,19	0,22	275 (225 – 295)
K2	E	0,10	2,5	0,048	0,060	0,070	0,095	0,12	0,14	0,18	0,20	245 (200 – 260)
K3	E	0,10	2,5	0,048	0,060	0,070	0,095	0,12	0,14	0,18	0,20	205 (170 – 220)
K4	E	0,10	2,5	0,048	0,060	0,070	0,095	0,12	0,14	0,18	0,20	200 (160 – 210)
K5	E	0,10	2,5	0,044	0,055	0,065	0,085	0,11	0,13	0,16	0,18	120 (100 – 125)
K6	E	0,10	2,5	0,048	0,060	0,070	0,095	0,12	0,14	0,18	0,20	175 (140 – 185)
K7	E	0,10	2,5	0,044	0,055	0,065	0,085	0,11	0,13	0,16	0,18	155 (125 – 165)
N1	E	0,10	2,5	0,048	0,060	0,070	0,095	0,12	0,14	0,18	0,20	740 (600 – 800)
N2	E	0,10	2,5	0,048	0,060	0,070	0,095	0,12	0,14	0,18	0,20	475 (385 – 510)
N3	E	0,10	2,5	0,040	0,050	0,060	0,080	0,10	0,12	0,15	0,17	500 (400 – 600)
N11	E	0,10	2,5	0,048	0,060	0,070	0,095	0,12	0,14	0,18	0,20	370 (300 – 400)
S1	E	0,030	2,5	0,028	0,036	0,042	0,055	0,070	0,085	0,10	0,12	60 (37 – 85)
S2	E	0,030	2,5	0,028	0,036	0,042	0,055	0,070	0,085	0,10	0,12	50 (30 – 70)
S3	E	0,030	2,5	0,026	0,032	0,038	0,050	0,065	0,075	0,095	0,11	43 (26 – 60)
S11	E	0,080	2,5	0,028	0,034	0,042	0,055	0,070	0,085	0,10	0,12	160 (135 – 190)
S12	E	0,080	2,5	0,028	0,034	0,042	0,055	0,070	0,085	0,10	0,12	125 (105 – 145)
S13	E	0,080	2,5	0,028	0,034	0,042	0,055	0,070	0,085	0,10	0,12	125 (105 – 145)
H8	M/A/D	0,050	2,5	0,024	0,028	0,034	0,046	0,060	0,070	0,085	0,10	155 (130 – 185)
H21	M/A/D	0,050	2,5	0,024	0,028	0,034	0,046	0,060	0,070	0,085	0,10	155 (130 – 185)
H31	M/A/D	0,050	2,5	0,020	0,024	0,030	0,040	0,050	0,060	0,075	0,085	120 (100 – 140)

For cutting data recalculations, see page 411-418.

SMG = Seco material group

Coolant = A=air D=dry E=emulsion M=mist spray

v_c = m/min

f_z = mm

a_p (mm)/DC (mm)= factor

a_e (mm)/DC (mm)= factor

All cutting data are target values

Cutting data – JS520 Side milling

SMG		a _g /DC	a _p /DC	f _z											v _c
				4	5	6	8	10	12	14	16	20	25		
P1	E/M/A	0,10	2,0	0,034	0,044	0,050	0,070	0,085	0,10	0,12	0,13	0,15	0,17	175 (130 – 225)	
P2	E/M/A	0,10	2,0	0,036	0,044	0,055	0,070	0,090	0,10	0,12	0,13	0,15	0,17	170 (125 – 215)	
P3	E/M/A	0,10	2,0	0,034	0,042	0,050	0,065	0,085	0,10	0,11	0,12	0,14	0,16	175 (115 – 235)	
P4	E/M/A	0,10	2,0	0,032	0,040	0,048	0,065	0,080	0,095	0,11	0,12	0,14	0,16	155 (105 – 210)	
P5	E/M/A	0,10	2,0	0,032	0,040	0,048	0,065	0,080	0,095	0,11	0,12	0,14	0,15	150 (100 – 200)	
P6	E/M/A	0,10	2,0	0,032	0,040	0,048	0,065	0,080	0,095	0,11	0,12	0,13	0,15	130 (80 – 180)	
P7	E/M/A	0,10	2,0	0,032	0,040	0,048	0,065	0,080	0,095	0,11	0,12	0,13	0,15	120 (75 – 170)	
P8	E/M/A	0,10	2,0	0,034	0,042	0,050	0,065	0,085	0,10	0,11	0,12	0,14	0,16	115 (70 – 155)	
P11	E/M/A	0,10	2,0	0,032	0,040	0,048	0,065	0,080	0,095	0,11	0,12	0,13	0,15	120 (75 – 165)	
P12	E/M/A	0,10	1,6	0,018	0,022	0,026	0,036	0,044	0,050	0,060	0,065	0,075	0,085	100 (65 – 135)	
M1	E/M/A	0,10	2,0	0,032	0,040	0,048	0,065	0,080	0,095	0,11	0,12	0,14	0,15	155 (125 – 185)	
M2	E/M/A	0,10	2,0	0,030	0,036	0,044	0,060	0,075	0,085	0,095	0,11	0,12	0,14	125 (100 – 150)	
M3	E/M/A	0,10	2,0	0,032	0,040	0,048	0,065	0,080	0,095	0,11	0,12	0,14	0,15	100 (80 – 180)	
M4	E/M/A	0,10	1,5	0,028	0,034	0,042	0,055	0,070	0,085	0,095	0,10	0,12	0,13	75 (60 – 135)	
M5	E/M/A	0,10	1,5	0,028	0,034	0,042	0,055	0,070	0,085	0,095	0,10	0,12	0,13	65 (50 – 115)	
K1	E/M/A	0,10	2,0	0,036	0,044	0,055	0,070	0,090	0,10	0,12	0,13	0,15	0,17	145 (95 – 195)	
K2	E/M/A	0,10	2,0	0,032	0,040	0,048	0,065	0,080	0,095	0,11	0,12	0,14	0,15	130 (85 – 170)	
K3	E/M/A	0,10	2,0	0,032	0,040	0,048	0,065	0,080	0,095	0,11	0,12	0,14	0,15	110 (75 – 145)	
K4	E/M/A	0,10	2,0	0,032	0,040	0,048	0,065	0,080	0,095	0,11	0,12	0,14	0,15	105 (70 – 140)	
K5	E/M/A	0,10	2,0	0,028	0,036	0,044	0,060	0,070	0,085	0,095	0,11	0,12	0,14	130 (80 – 185)	
K6	E/M/A	0,10	2,0	0,032	0,040	0,048	0,065	0,080	0,095	0,11	0,12	0,14	0,15	190 (115 – 265)	
K7	E/M/A	0,10	2,0	0,028	0,036	0,044	0,060	0,070	0,085	0,095	0,11	0,12	0,14	170 (105 – 235)	
N1	E/M/A	0,10	2,0	0,032	0,040	0,048	0,065	0,080	0,095	0,11	0,12	0,14	0,15	495 (445 – 550)	
N2	E/M/A	0,10	2,0	0,032	0,040	0,048	0,065	0,080	0,095	0,11	0,12	0,14	0,15	395 (345 – 445)	
N3	E/M/A	0,10	2,0	0,032	0,040	0,048	0,065	0,080	0,095	0,11	0,12	0,14	0,15	265 (230 – 295)	
N11	E/M/A	0,10	2,0	0,032	0,040	0,048	0,065	0,080	0,095	0,11	0,12	0,14	0,15	395 (345 – 445)	
S1	E/M/A	0,060	2,0	0,020	0,024	0,030	0,040	0,050	0,060	0,065	0,075	0,085	0,095	60 (50 – 70)	
S2	E/M/A	0,060	2,0	0,020	0,024	0,030	0,040	0,050	0,060	0,065	0,075	0,085	0,095	48 (40 – 55)	
S3	E/M/A	0,060	2,0	0,020	0,024	0,030	0,040	0,050	0,060	0,065	0,075	0,085	0,095	40 (30 – 50)	
S11	E/M/A	0,10	2,0	0,032	0,040	0,048	0,065	0,080	0,095	0,11	0,12	0,14	0,15	85 (75 – 95)	
S12	E/M/A	0,10	2,0	0,032	0,040	0,048	0,065	0,080	0,095	0,11	0,12	0,14	0,15	65 (60 – 75)	
S13	E/M/A	0,10	1,7	0,028	0,034	0,042	0,055	0,070	0,085	0,095	0,10	0,12	0,13	55 (46 – 60)	
H5	M/A	0,10	2,0	0,020	0,026	0,030	0,040	0,050	0,060	0,065	0,075	0,085	0,095	100 (50 – 150)	
H8	M/A	0,10	1,7	0,014	0,018	0,022	0,028	0,036	0,042	0,046	0,050	0,060	0,065	105 (50 – 155)	
H11	M/A	0,10	2,0	0,020	0,026	0,030	0,040	0,050	0,060	0,065	0,075	0,085	0,095	65 (43 – 85)	
H12	M/A	0,10	1,4	0,010	0,013	0,016	0,020	0,026	0,030	0,034	0,038	0,044	0,050	65 (42 – 85)	
H21	M/A	0,10	1,7	0,014	0,018	0,022	0,028	0,036	0,042	0,046	0,050	0,060	0,065	105 (50 – 155)	
H31	M/A	0,10	1,7	0,010	0,013	0,016	0,020	0,026	0,032	0,036	0,038	0,044	0,050	80 (41 – 125)	
TS1	A/D	0,10	2,0	0,032	0,040	0,048	0,065	0,080	0,095	0,11	0,12	0,14	0,15	495 (445 – 550)	
TP1	A/D	0,10	2,0	0,032	0,040	0,048	0,065	0,080	0,095	0,11	0,12	0,14	0,15	395 (345 – 445)	
GR1	A/D	0,10	2,0	0,032	0,040	0,048	0,065	0,080	0,095	0,11	0,12	0,14	0,15	495 (445 – 550)	

For cutting data recalculations, see page 411-418.

SMG = Seco material group

Coolant = A=air D=dry E=emulsion M=mist spray

v_c = m/min

f_z = mm

a_p (mm)/DC (mm)= factor

a_g (mm)/DC (mm)= factor

All cutting data are target values

JS522 long flute finisher, with its special geometry designed to machine high shoulders with excellent surface finish and perpendicularity.



Cutting data – JS522 Side milling semi finishing

SMG		a _e /DC	a _p /DC	f _z									v _c
				6	8	10	12	16	20	25	32		
P1	E/M/A	0,050	4,0	0,046	0,060	0,075	0,090	0,11	0,13	0,14	0,16	160 (140 – 180)	
P2	E/M/A	0,050	4,0	0,046	0,060	0,075	0,090	0,11	0,13	0,15	0,17	155 (135 – 175)	
P3	E/M/A	0,050	4,0	0,044	0,060	0,075	0,085	0,11	0,12	0,14	0,16	165 (140 – 190)	
P4	E/M/A	0,050	4,0	0,042	0,055	0,070	0,085	0,10	0,12	0,14	0,15	145 (125 – 170)	
P5	E/M/A	0,050	4,0	0,042	0,055	0,070	0,085	0,10	0,12	0,13	0,15	140 (120 – 160)	
P6	E/M/A	0,050	4,0	0,042	0,055	0,070	0,080	0,10	0,12	0,13	0,15	120 (100 – 140)	
P7	E/M/A	0,050	4,0	0,042	0,055	0,070	0,080	0,10	0,12	0,13	0,15	115 (95 – 130)	
P8	E/M/A	0,050	4,0	0,044	0,060	0,075	0,085	0,11	0,12	0,14	0,16	105 (90 – 125)	
P11	E/M/A	0,050	4,0	0,042	0,055	0,070	0,080	0,10	0,12	0,13	0,15	110 (90 – 130)	
P12	E/M/A	0,050	4,0	0,024	0,030	0,038	0,046	0,055	0,065	0,075	0,085	70 (60 – 80)	
M1	E/M/A	0,050	4,0	0,042	0,055	0,070	0,085	0,10	0,12	0,13	0,15	110 (85 – 135)	
M2	E/M/A	0,050	4,0	0,038	0,050	0,065	0,075	0,095	0,11	0,12	0,14	90 (70 – 110)	
M3	E/M/A	0,050	4,0	0,042	0,055	0,070	0,085	0,10	0,12	0,13	0,15	80 (60 – 100)	
M4	E/M/A	0,050	4,0	0,036	0,048	0,060	0,070	0,090	0,10	0,12	0,13	60 (46 – 75)	
M5	E/M/A	0,050	4,0	0,036	0,048	0,060	0,070	0,090	0,10	0,12	0,13	50 (38 – 65)	
K1	E/M/A	0,050	4,0	0,046	0,060	0,075	0,090	0,11	0,13	0,15	0,17	120 (100 – 140)	
K2	E/M/A	0,050	4,0	0,042	0,055	0,070	0,085	0,10	0,12	0,13	0,15	105 (85 – 120)	
K3	E/M/A	0,050	4,0	0,042	0,055	0,070	0,085	0,10	0,12	0,13	0,15	90 (75 – 105)	
K4	E/M/A	0,050	4,0	0,042	0,055	0,070	0,085	0,10	0,12	0,13	0,15	85 (70 – 100)	
K5	E/M/A	0,050	4,0	0,038	0,050	0,065	0,075	0,090	0,11	0,12	0,14	100 (80 – 120)	
K6	E/M/A	0,050	4,0	0,042	0,055	0,070	0,085	0,10	0,12	0,13	0,15	150 (120 – 180)	
K7	E/M/A	0,050	4,0	0,038	0,050	0,065	0,075	0,090	0,11	0,12	0,14	130 (105 – 155)	
N1	E/M/A	0,050	4,0	0,042	0,055	0,070	0,085	0,10	0,12	0,13	0,15	400 (300 – 500)	
N2	E/M/A	0,050	4,0	0,042	0,055	0,070	0,085	0,10	0,12	0,13	0,15	300 (200 – 400)	
N3	E/M/A	0,050	4,0	0,042	0,055	0,070	0,085	0,10	0,12	0,13	0,15	200 (135 – 265)	
N11	E/M/A	0,050	4,0	0,042	0,055	0,070	0,085	0,10	0,12	0,13	0,15	300 (250 – 350)	
S1	E/M/A	0,040	4,0	0,020	0,026	0,034	0,040	0,050	0,055	0,065	0,070	49 (39 – 60)	
S2	E/M/A	0,040	4,0	0,020	0,026	0,034	0,040	0,050	0,055	0,065	0,070	40 (32 – 48)	
S3	E/M/A	0,030	4,0	0,018	0,024	0,030	0,036	0,044	0,050	0,055	0,065	42 (31 – 50)	
S11	E/M/A	0,050	4,0	0,042	0,055	0,070	0,085	0,10	0,12	0,13	0,15	125 (100 – 150)	
S12	E/M/A	0,050	4,0	0,042	0,055	0,070	0,085	0,10	0,12	0,13	0,15	95 (75 – 115)	
S13	E/M/A	0,050	4,0	0,036	0,048	0,060	0,070	0,090	0,10	0,12	0,13	75 (60 – 90)	
TS1	A/D	0,050	4,0	0,042	0,055	0,070	0,085	0,10	0,12	0,13	0,15	500 (400 – 600)	
TP1	A/D	0,050	4,0	0,042	0,055	0,070	0,085	0,10	0,12	0,13	0,15	400 (300 – 500)	
GR1	A/D	0,050	4,0	0,042	0,055	0,070	0,085	0,10	0,12	0,13	0,15	500 (400 – 600)	

For cutting data recalculations, see page 411-418

SMG = Seco material group

Coolant = A=air D=dry E=emulsion M=mist spray

v_c = m/min

f_z = mm

a_p (mm)/DC (mm)= factor

a_e (mm)/DC (mm)= factor

All cutting data are target values

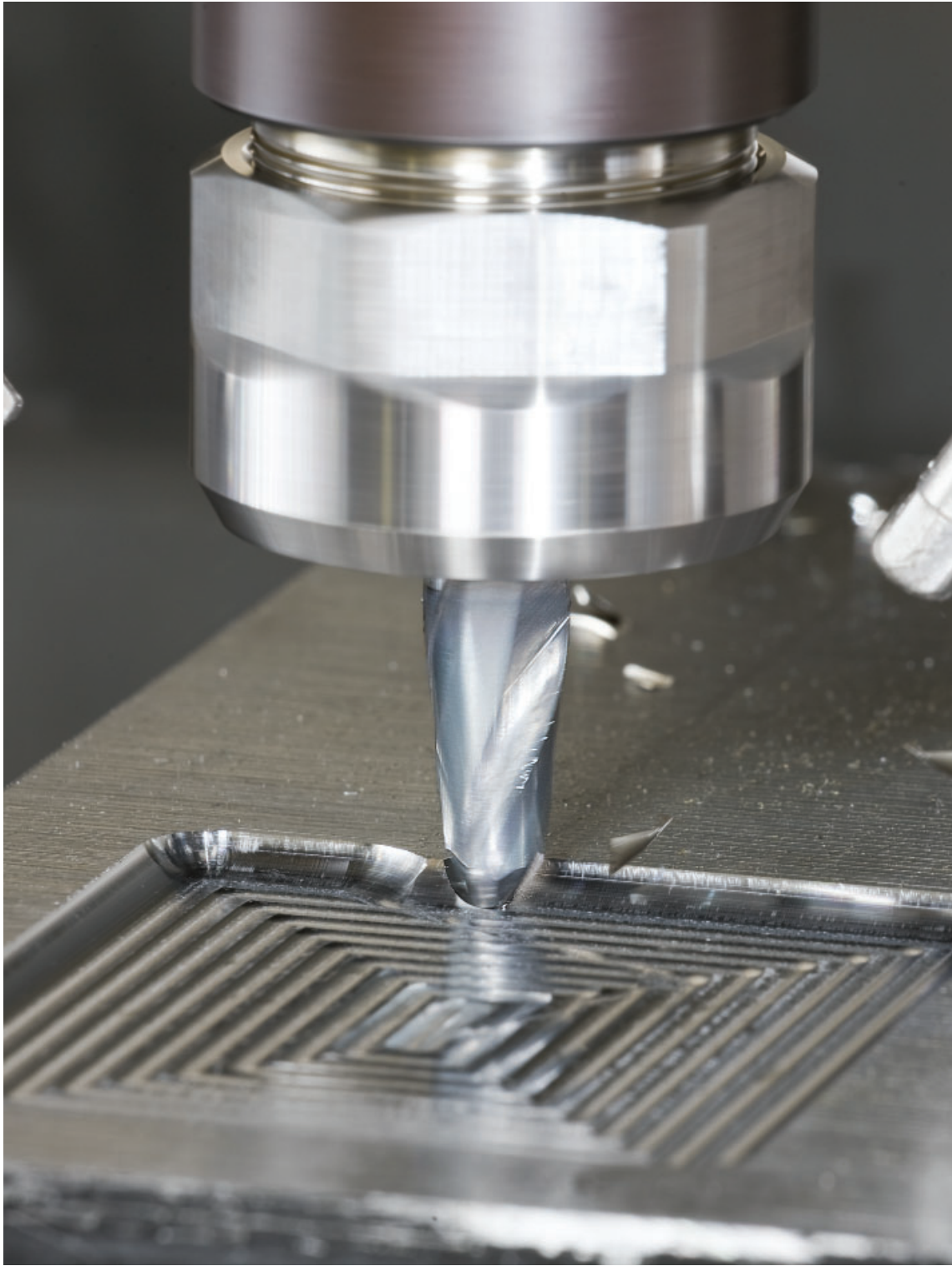

JS532 - High performance - Universal - Ball nose - 2 Flutes - Cylindrical



Tolerances:
 DMM=h5
 DC=e8
 RE= ±0,01 mm
 Regrind possible if DC is ≥Ø6

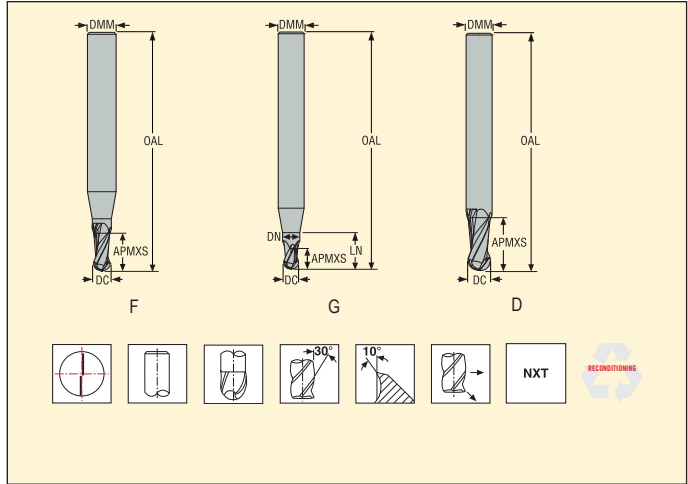

Ordering and Product No.	Designation	Length index	Tool shape	Dimensions in mm						PCEDC	Cylindrical
				DC	DMM	APMXS	OAL	LN	DN		
02928193	JS532010F1B.0Z2-NXT	1	F	1,0	3	2	38	3,1	1,0	2	■
02928194	JS532015F1B.0Z2-NXT	1	F	1,5	3	3	38	4,6	1,5	2	■
02928195	JS532020F1B.0Z2-NXT	1	F	2,0	3	4	38	6,1	2,0	2	■
02928197	JS532025F1B.0Z2-NXT	1	F	2,5	3	5	38	7,1	2,5	2	■
02928199	JS532030D1B.0Z2-NXT	1	D	3,0	3	6	38	-	-	2	■
02928202	JS532035F1B.0Z2-NXT	1	F	3,5	6	7	57	11,2	3,5	2	■
02928203	JS532040F1B.0Z2-NXT	1	F	4,0	6	8	57	-	4,0	2	■
02928206	JS532045F1B.0Z2-NXT	1	F	4,5	6	9	57	13,75	4,5	2	■
02928207	JS532050F1B.0Z2-NXT	1	F	5,0	6	10	57	14,9	5,0	2	■
02928210	JS532060D1B.0Z2-NXT	1	D	6,0	6	12	57	-	-	2	■
02928213	JS532080D1B.0Z2-NXT	1	D	8,0	8	16	63	-	-	2	■
02928216	JS532100D1B.0Z2-NXT	1	D	10,0	10	20	72	-	-	2	■
02928219	JS532120D1B.0Z2-NXT	1	D	12,0	12	24	83	-	-	2	■
02928222	JS532160D1B.0Z2-NXT	1	D	16,0	16	32	92	-	-	2	■
02928225	JS532200D1B.0Z2-NXT	1	D	20,0	20	40	104	-	-	2	■
02928196	JS532020G2B.0Z2-NXT	2	G	2,0	3	2	38	8,0	1,9	2	■
02928198	JS532025G2B.0Z2-NXT	2	G	2,5	3	3	38	8,0	2,4	2	■
02928200	JS532030E2B.0Z2-NXT	2	E	3,0	3	3	38	10,0	2,85	2	■
02928204	JS532040G2B.0Z2-NXT	2	G	4,0	6	4	57	15,0	3,8	2	■
02928208	JS532050G2B.0Z2-NXT	2	G	5,0	6	5	57	20,0	4,8	2	■
02928211	JS532060E2B.0Z2-NXT	2	E	6,0	6	6	63	25,0	5,7	2	■
02928214	JS532080E2B.0Z2-NXT	2	E	8,0	8	8	80	35,0	7,6	2	■
02928217	JS532100E2B.0Z2-NXT	2	E	10,0	10	10	82	40,0	9,5	2	■
02928220	JS532120E2B.0Z2-NXT	2	E	12,0	12	12	100	50,0	11,4	2	■
02928223	JS532160E2B.0Z2-NXT	2	E	16,0	16	16	125	72,0	15,2	2	■
02928201	JS532030E3B.0Z2-NXT	3	E	3,0	3	3	52	20,0	2,85	2	■
02928205	JS532040G3B.0Z2-NXT	3	G	4,0	6	4	63	24,0	3,8	2	■
02928209	JS532050G3B.0Z2-NXT	3	G	5,0	6	5	75	35,0	4,8	2	■
02928212	JS532060E3B.0Z2-NXT	3	E	6,0	6	6	80	42,0	5,7	2	■
02928215	JS532080E3B.0Z2-NXT	3	E	8,0	8	8	100	60,0	7,6	2	■
02928218	JS532100E3B.0Z2-NXT	3	E	10,0	10	10	125	80,0	9,5	2	■
02928221	JS532120E3B.0Z2-NXT	3	E	12,0	12	12	125	75,0	11,4	2	■
02928224	JS532160E3B.0Z2-NXT	3	E	16,0	16	16	150	100,0	15,2	2	■

■ Stock standard. Subject to change refer to current price- and stock-list

Cutting data – JS532 Copy milling roughing

SMG		a _e /DC	a _p /DC	f _z													v _c
				1	2	3	4	5	6	8	10	12	16	20			
P1	M/A/D/E	0.030	0.80	0,0060	0,012	0,018	0,024	0,030	0,036	0,048	0,060	0,070	0,095	0,12	405 (365 – 450)		
P2	M/A/D/E	0.030	0.80	0,0060	0,012	0,018	0,024	0,030	0,036	0,048	0,060	0,070	0,095	0,12	395 (355 – 435)		
P3	M/A/D/E	0.030	0.80	0,0060	0,012	0,018	0,024	0,030	0,036	0,048	0,060	0,070	0,095	0,12	340 (305 – 375)		
P4	M/A/D/E	0.030	0.80	0,0060	0,012	0,018	0,024	0,030	0,036	0,048	0,060	0,070	0,095	0,12	300 (270 – 330)		
P5	M/A/D/E	0.030	0.80	0,0060	0,012	0,018	0,024	0,030	0,036	0,048	0,060	0,070	0,095	0,12	285 (255 – 315)		
P6	M/A/D/E	0.030	0.80	0,0060	0,012	0,018	0,024	0,030	0,036	0,048	0,060	0,070	0,095	0,12	270 (240 – 300)		
P7	M/A/D/E	0.030	0.80	0,0060	0,012	0,018	0,024	0,030	0,036	0,048	0,060	0,070	0,095	0,12	255 (225 – 285)		
P8	M/A/D/E	0.030	0.80	0,0060	0,012	0,018	0,024	0,030	0,036	0,048	0,060	0,070	0,095	0,12	240 (215 – 270)		
P11	M/A/D/E	0.030	0.80	0,0060	0,012	0,018	0,024	0,030	0,036	0,048	0,060	0,070	0,095	0,12	250 (220 – 275)		
P12	M/A/D/E	0.030	0.80	0,0044	0,0090	0,013	0,018	0,022	0,026	0,036	0,044	0,050	0,065	0,075	150 (135 – 165)		
M1	E	0.030	0.80	0,0060	0,012	0,018	0,024	0,030	0,036	0,048	0,060	0,070	0,095	0,11	200 (170 – 225)		
M2	E	0.030	0.80	0,0060	0,012	0,018	0,024	0,030	0,036	0,048	0,060	0,070	0,085	0,10	160 (140 – 185)		
M3	E	0.030	0.80	0,0044	0,0090	0,013	0,018	0,022	0,026	0,036	0,044	0,050	0,065	0,075	175 (145 – 200)		
M4	E	0.030	0.80	0,0038	0,0080	0,012	0,016	0,019	0,024	0,032	0,038	0,046	0,055	0,065	130 (110 – 150)		
M5	E	0.030	0.80	0,0038	0,0080	0,012	0,016	0,019	0,024	0,032	0,038	0,046	0,055	0,065	110 (90 – 125)		
K1	E	0.030	0.80	0,0060	0,012	0,018	0,024	0,030	0,036	0,048	0,060	0,070	0,095	0,12	285 (255 – 315)		
K2	E	0.030	0.80	0,0060	0,012	0,018	0,024	0,030	0,036	0,048	0,060	0,070	0,095	0,12	250 (220 – 275)		
K3	E	0.030	0.80	0,0044	0,0090	0,013	0,018	0,022	0,026	0,036	0,044	0,050	0,065	0,075	215 (190 – 235)		
K4	E	0.030	0.80	0,0044	0,0090	0,013	0,018	0,022	0,026	0,036	0,044	0,050	0,065	0,075	205 (185 – 225)		
K5	E	0.030	0.80	0,0040	0,0080	0,012	0,016	0,020	0,024	0,032	0,040	0,048	0,060	0,065	225 (195 – 250)		
K6	E	0.030	0.80	0,0044	0,0090	0,013	0,018	0,022	0,026	0,036	0,044	0,050	0,065	0,075	330 (290 – 370)		
K7	E	0.030	0.80	0,0040	0,0080	0,012	0,016	0,020	0,024	0,032	0,040	0,048	0,060	0,065	285 (250 – 320)		
N1	E	0.030	0.80	0,0080	0,016	0,024	0,032	0,040	0,048	0,065	0,080	0,095	0,13	0,16	1225 (1075 – 1375)		
N2	E	0.030	0.80	0,0080	0,016	0,024	0,032	0,040	0,048	0,065	0,080	0,095	0,13	0,16	1075 (910 – 1225)		
N3	E	0.030	0.80	0,0080	0,016	0,024	0,032	0,040	0,048	0,065	0,080	0,095	0,13	0,16	710 (610 – 810)		
N11	E	0.030	0.80	0,0060	0,012	0,018	0,024	0,030	0,036	0,048	0,060	0,070	0,095	0,12	630 (550 – 700)		
S1	E	0.030	0.80	0,0050	0,010	0,015	0,020	0,024	0,030	0,040	0,050	0,060	0,080	0,090	110 (95 – 125)		
S2	E	0.030	0.80	0,0050	0,010	0,015	0,020	0,024	0,030	0,040	0,050	0,060	0,080	0,090	90 (80 – 100)		
S3	E	0.030	0.80	0,0030	0,0060	0,0090	0,012	0,015	0,018	0,024	0,030	0,034	0,044	0,050	85 (70 – 100)		
S11	E	0.030	0.80	0,0060	0,012	0,018	0,024	0,030	0,036	0,048	0,060	0,070	0,095	0,12	195 (175 – 215)		
S12	E	0.030	0.80	0,0060	0,012	0,018	0,024	0,030	0,036	0,048	0,060	0,070	0,095	0,12	150 (135 – 165)		
S13	E	0.030	0.80	0,0060	0,012	0,018	0,024	0,030	0,036	0,048	0,060	0,070	0,095	0,12	115 (105 – 130)		
TS1	A	0.030	0.80	0,0080	0,016	0,024	0,032	0,040	0,048	0,065	0,080	0,095	0,13	0,16	1075 (990 – 1150)		
TP1	A	0.030	0.80	0,0080	0,016	0,024	0,032	0,040	0,048	0,065	0,080	0,095	0,13	0,16	1075 (990 – 1150)		
GR1	A	0.030	0.80	0,0080	0,016	0,024	0,032	0,040	0,048	0,065	0,080	0,095	0,13	0,16	1075 (990 – 1150)		

For cutting data recalculations, see page 411-418.

SMG = Seco material group

Coolant = A=air D=dry E=emulsion M=mist spray

v_c = m/min

f_z = mm

a_p (mm)/DC (mm)= factor

a_e (mm)/DC (mm)= factor

All cutting data are target values

Cutting data – JS533 Copy milling roughing

SMG		a _g /DC	a _p /DC	f _z													v _c
				1	2	3	4	5	6	8	10	12	16	20			
P1	M/A/D/E	0,030	0,80	0,0050	0,010	0,015	0,020	0,024	0,030	0,040	0,050	0,060	0,080	0,095	385 (345 – 425)		
P2	M/A/D/E	0,030	0,80	0,0050	0,010	0,015	0,020	0,024	0,030	0,040	0,050	0,060	0,080	0,10	375 (335 – 415)		
P3	M/A/D/E	0,030	0,80	0,0050	0,010	0,015	0,020	0,024	0,030	0,040	0,050	0,060	0,080	0,095	320 (290 – 355)		
P4	M/A/D/E	0,030	0,80	0,0050	0,010	0,015	0,020	0,024	0,030	0,040	0,050	0,060	0,080	0,090	285 (255 – 315)		
P5	M/A/D/E	0,030	0,80	0,0050	0,010	0,015	0,020	0,024	0,030	0,040	0,050	0,060	0,080	0,090	270 (240 – 300)		
P6	M/A/D/E	0,030	0,80	0,0050	0,010	0,015	0,020	0,024	0,030	0,040	0,050	0,060	0,075	0,090	245 (215 – 270)		
P7	M/A/D/E	0,030	0,80	0,0050	0,010	0,015	0,020	0,024	0,030	0,040	0,050	0,060	0,075	0,090	230 (205 – 255)		
P8	M/A/D/E	0,030	0,80	0,0050	0,010	0,015	0,020	0,024	0,030	0,040	0,050	0,060	0,080	0,095	220 (195 – 240)		
P11	M/A/D/E	0,030	0,80	0,0050	0,010	0,015	0,020	0,024	0,030	0,040	0,050	0,060	0,075	0,090	225 (200 – 250)		
P12	M/A/D/E	0,030	0,80	0,0030	0,0060	0,0090	0,012	0,015	0,018	0,024	0,030	0,034	0,042	0,050	135 (120 – 150)		
M1	E	0,030	0,80	0,0042	0,0085	0,012	0,017	0,020	0,024	0,034	0,042	0,048	0,060	0,070	210 (180 – 235)		
M2	E	0,030	0,80	0,0038	0,0075	0,011	0,015	0,019	0,022	0,030	0,038	0,044	0,055	0,065	170 (145 – 195)		
M3	E	0,030	0,80	0,0038	0,0075	0,011	0,015	0,019	0,022	0,030	0,038	0,044	0,055	0,065	170 (145 – 200)		
M4	E	0,030	0,80	0,0032	0,0065	0,010	0,013	0,016	0,020	0,026	0,032	0,038	0,048	0,055	130 (110 – 150)		
M5	E	0,030	0,80	0,0032	0,0065	0,010	0,013	0,016	0,020	0,026	0,032	0,038	0,048	0,055	110 (90 – 125)		
K1	E	0,030	0,80	0,0050	0,010	0,015	0,020	0,024	0,030	0,040	0,050	0,060	0,080	0,10	270 (240 – 300)		
K2	E	0,030	0,80	0,0050	0,010	0,015	0,020	0,024	0,030	0,040	0,050	0,060	0,080	0,10	235 (210 – 260)		
K3	E	0,030	0,80	0,0050	0,010	0,015	0,020	0,024	0,030	0,040	0,050	0,060	0,080	0,10	200 (175 – 220)		
K4	E	0,030	0,80	0,0050	0,010	0,015	0,020	0,024	0,030	0,040	0,050	0,060	0,080	0,10	190 (170 – 210)		
K5	E	0,030	0,80	0,0050	0,010	0,015	0,020	0,024	0,030	0,040	0,050	0,060	0,080	0,10	215 (190 – 245)		
K6	E	0,030	0,80	0,0050	0,010	0,015	0,020	0,024	0,030	0,040	0,050	0,060	0,080	0,10	320 (280 – 360)		
K7	E	0,030	0,80	0,0050	0,010	0,015	0,020	0,024	0,030	0,040	0,050	0,060	0,080	0,10	280 (245 – 315)		
N1	E	0,030	0,80	0,0070	0,014	0,020	0,028	0,036	0,042	0,055	0,070	0,085	0,11	0,14	1150 (1000 – 1275)		
N2	E	0,030	0,80	0,0070	0,014	0,020	0,028	0,036	0,042	0,055	0,070	0,085	0,11	0,14	1000 (860 – 1150)		
N3	E	0,030	0,80	0,0070	0,014	0,020	0,028	0,036	0,042	0,055	0,070	0,085	0,11	0,14	670 (570 – 760)		
N11	E	0,030	0,80	0,0060	0,012	0,018	0,024	0,030	0,036	0,048	0,060	0,070	0,095	0,12	550 (485 – 620)		
S1	E	0,030	0,80	0,0044	0,0090	0,013	0,018	0,022	0,026	0,036	0,044	0,050	0,065	0,075	110 (100 – 125)		
S2	E	0,030	0,80	0,0044	0,0090	0,013	0,018	0,022	0,026	0,036	0,044	0,050	0,065	0,075	90 (80 – 100)		
S11	E	0,030	0,80	0,0050	0,010	0,015	0,020	0,024	0,030	0,040	0,050	0,060	0,080	0,090	185 (165 – 205)		
S12	E	0,030	0,80	0,0050	0,010	0,015	0,020	0,024	0,030	0,040	0,050	0,060	0,080	0,090	140 (130 – 155)		
S13	E	0,030	0,80	0,0046	0,0095	0,014	0,019	0,024	0,028	0,038	0,046	0,055	0,070	0,080	110 (100 – 120)		
TS1	A	0,030	0,80	0,0060	0,012	0,018	0,024	0,030	0,036	0,048	0,060	0,070	0,095	0,12	1000 (930 – 1075)		
TP1	A	0,030	0,80	0,0060	0,012	0,018	0,024	0,030	0,036	0,048	0,060	0,070	0,095	0,12	1000 (930 – 1075)		
GR1	A	0,030	0,80	0,0060	0,012	0,018	0,024	0,030	0,036	0,048	0,060	0,070	0,095	0,12	1000 (930 – 1075)		

For cutting data recalculations, see page 411-418.

SMG = Seco material group

Coolant = A=air D=dry E=emulsion M=mist spray

v_c = m/min

f_z = mm

a_p (mm)/DC (mm)= factor

a_g (mm)/DC (mm)= factor

All cutting data are target values

Cutting data – JS534 Copy milling roughing

SMG		a _g /DC	a _p /DC	f _z											v _c
				2	3	4	5	6	8	10	12	16	20		
P1	M/A/D/E	0,030	0,8	0,011	0,016	0,022	0,028	0,032	0,044	0,055	0,065	0,080	0,090	335 (300 – 370)	
P2	M/A/D/E	0,030	0,8	0,011	0,017	0,022	0,028	0,034	0,044	0,055	0,065	0,080	0,095	325 (290 – 360)	
P3	M/A/D/E	0,030	0,8	0,011	0,016	0,022	0,026	0,032	0,042	0,055	0,060	0,075	0,090	280 (250 – 310)	
P4	M/A/D/E	0,030	0,8	0,010	0,015	0,020	0,026	0,030	0,042	0,050	0,060	0,075	0,085	250 (225 – 275)	
P5	M/A/D/E	0,030	0,8	0,010	0,015	0,020	0,026	0,030	0,040	0,050	0,060	0,075	0,085	240 (215 – 265)	
P6	M/A/D/E	0,030	0,8	0,010	0,015	0,020	0,024	0,030	0,040	0,050	0,060	0,075	0,085	225 (200 – 250)	
P7	M/A/D/E	0,030	0,8	0,010	0,015	0,020	0,024	0,030	0,040	0,050	0,060	0,075	0,085	215 (190 – 235)	
P8	M/A/D/E	0,030	0,8	0,011	0,016	0,022	0,026	0,032	0,042	0,055	0,060	0,075	0,090	200 (175 – 220)	
P11	M/A/D/E	0,030	0,8	0,010	0,015	0,020	0,024	0,030	0,040	0,050	0,060	0,075	0,085	205 (185 – 230)	
P12	M/A/D/E	0,030	0,8	0,0055	0,0085	0,011	0,014	0,017	0,022	0,028	0,032	0,040	0,048	125 (115 – 140)	
M1	E	0,030	0,8	0,0070	0,011	0,014	0,018	0,022	0,028	0,036	0,042	0,050	0,060	180 (155 – 205)	
M2	E	0,030	0,8	0,0065	0,0095	0,013	0,016	0,019	0,026	0,032	0,038	0,048	0,055	145 (125 – 170)	
M3	E	0,030	0,8	0,0065	0,0095	0,013	0,016	0,019	0,026	0,032	0,038	0,048	0,055	160 (135 – 185)	
M4	E	0,030	0,8	0,0055	0,0085	0,011	0,014	0,017	0,022	0,028	0,034	0,042	0,048	120 (100 – 140)	
M5	E	0,030	0,8	0,0055	0,0085	0,011	0,014	0,017	0,022	0,028	0,034	0,042	0,048	100 (85 – 115)	
K1	E	0,030	0,8	0,010	0,015	0,020	0,026	0,030	0,040	0,050	0,060	0,075	0,085	240 (215 – 265)	
K2	E	0,030	0,8	0,0090	0,014	0,018	0,022	0,028	0,036	0,046	0,055	0,065	0,075	210 (185 – 230)	
K3	E	0,030	0,8	0,0065	0,0095	0,013	0,016	0,019	0,026	0,032	0,038	0,048	0,055	180 (160 – 200)	
K4	E	0,030	0,8	0,0065	0,0095	0,013	0,016	0,019	0,026	0,032	0,038	0,048	0,055	170 (155 – 190)	
K5	E	0,030	0,8	0,0060	0,0085	0,012	0,014	0,017	0,024	0,028	0,034	0,042	0,048	205 (180 – 230)	
K6	E	0,030	0,8	0,0065	0,0095	0,013	0,016	0,019	0,026	0,032	0,038	0,048	0,055	300 (260 – 335)	
K7	E	0,030	0,8	0,0060	0,0085	0,012	0,014	0,017	0,024	0,028	0,034	0,042	0,048	260 (230 – 295)	
N1	E	0,030	0,8	0,013	0,019	0,026	0,032	0,038	0,050	0,065	0,075	0,095	0,11	990 (860 – 1100)	
N2	E	0,030	0,8	0,013	0,019	0,026	0,032	0,038	0,050	0,065	0,075	0,095	0,11	860 (740 – 990)	
N3	E	0,030	0,8	0,013	0,019	0,026	0,032	0,038	0,050	0,065	0,075	0,095	0,11	580 (495 – 660)	
N11	E	0,030	0,8	0,010	0,015	0,020	0,026	0,030	0,040	0,050	0,060	0,075	0,085	490 (430 – 550)	
S1	E	0,030	0,8	0,0065	0,0095	0,013	0,016	0,019	0,026	0,032	0,038	0,048	0,055	115 (90 – 115)	
S2	E	0,030	0,8	0,0065	0,0095	0,013	0,016	0,019	0,026	0,032	0,038	0,048	0,055	90 (70 – 90)	
S3	E	0,030	0,8	0,0065	0,0095	0,013	0,016	0,019	0,026	0,032	0,038	0,048	0,055	90 (65 – 90)	
S11	E	0,030	0,8	0,013	0,019	0,026	0,032	0,038	0,050	0,065	0,075	0,095	0,11	175 (145 – 175)	
S12	E	0,030	0,8	0,013	0,019	0,026	0,032	0,038	0,050	0,065	0,075	0,095	0,11	135 (110 – 135)	
S13	E	0,030	0,8	0,011	0,017	0,022	0,028	0,034	0,044	0,055	0,065	0,080	0,095	105 (85 – 105)	
TS1	A	0,030	0,8	0,013	0,019	0,026	0,032	0,038	0,050	0,065	0,075	0,095	0,11	860 (790 – 920)	
TP1	A	0,030	0,8	0,013	0,019	0,026	0,032	0,038	0,050	0,065	0,075	0,095	0,11	860 (790 – 920)	
GR1	A	0,030	0,8	0,013	0,019	0,026	0,032	0,038	0,050	0,065	0,075	0,095	0,11	860 (790 – 920)	

For cutting data recalculations, see page 411-418.

SMG = Seco material group

Coolant = A=air D=dry E=emulsion M=mist spray

v_c = m/min

f_z = mm

a_p (mm)/DC (mm)= factor

a_g (mm)/DC (mm)= factor

All cutting data are target values

Cutting data – JS506 Chamfering

SMG		a _e /DC	a _p /DC	f _z						
				3	4	6	8	10	12	
P1	M/A/D/E	0,10	0,30	0,028	0,038	0,055	0,075	0,095	0,11	195 (170 – 225)
P2	M/A/D/E	0,10	0,30	0,028	0,038	0,055	0,075	0,095	0,11	190 (165 – 215)
P3	M/A/D/E	0,10	0,30	0,026	0,036	0,055	0,070	0,090	0,11	165 (145 – 190)
P4	M/A/D/E	0,10	0,30	0,026	0,036	0,055	0,070	0,090	0,10	145 (125 – 165)
P5	M/A/D/E	0,10	0,30	0,026	0,034	0,050	0,070	0,085	0,10	140 (125 – 160)
P6	M/A/D/E	0,10	0,30	0,026	0,034	0,050	0,070	0,085	0,10	160 (140 – 180)
P7	M/A/D/E	0,10	0,30	0,026	0,034	0,050	0,070	0,085	0,10	150 (130 – 170)
P8	M/A/D/E	0,10	0,30	0,026	0,036	0,055	0,070	0,090	0,11	140 (120 – 160)
P11	M/A/D/E	0,10	0,30	0,026	0,034	0,050	0,070	0,085	0,10	145 (125 – 165)
P12	M/A/D/E	0,10	0,25	0,015	0,020	0,030	0,040	0,050	0,060	100 (85 – 115)
M1	E/M/A	0,10	0,30	0,028	0,038	0,055	0,075	0,095	0,11	115 (90 – 135)
M2	E/M/A	0,10	0,30	0,026	0,034	0,050	0,070	0,085	0,10	95 (75 – 115)
M3	E/M/A	0,10	0,30	0,026	0,034	0,050	0,070	0,085	0,10	60 (43 – 80)
M4	E/M/A	0,10	0,20	0,017	0,022	0,034	0,046	0,055	0,065	45 (31 – 60)
M5	E/M/A	0,10	0,20	0,017	0,022	0,034	0,046	0,055	0,065	38 (26 – 49)
K1	A/D/M/E	0,10	0,30	0,028	0,038	0,055	0,075	0,095	0,11	195 (170 – 220)
K2	A/D/M/E	0,10	0,30	0,026	0,034	0,050	0,070	0,085	0,10	170 (150 – 195)
K3	A/D/M/E	0,10	0,30	0,026	0,034	0,050	0,070	0,085	0,10	145 (125 – 165)
K4	A/D/M/E	0,10	0,30	0,026	0,034	0,050	0,070	0,085	0,10	140 (120 – 155)
K5	A/D/M/E	0,10	0,30	0,024	0,032	0,046	0,060	0,080	0,090	85 (70 – 95)
K6	A/D/M/E	0,10	0,30	0,026	0,034	0,050	0,070	0,085	0,10	120 (105 – 140)
K7	A/D/M/E	0,10	0,30	0,024	0,032	0,046	0,060	0,080	0,090	105 (95 – 120)
N1	E/M/A	0,10	0,30	0,026	0,034	0,050	0,070	0,085	0,10	475 (425 – 520)
N2	E/M/A	0,10	0,30	0,026	0,034	0,050	0,070	0,085	0,10	305 (275 – 335)
N3	E/M/A	0,10	0,30	0,026	0,034	0,050	0,070	0,085	0,10	205 (180 – 225)
N11	E/M/A	0,10	0,30	0,026	0,034	0,050	0,070	0,085	0,10	270 (245 – 295)
S1	E	0,10	0,30	0,024	0,032	0,048	0,065	0,080	0,095	41 (14 – 70)
S2	E	0,10	0,30	0,024	0,032	0,048	0,065	0,080	0,095	33 (11 – 55)
S3	E	0,10	0,30	0,024	0,032	0,048	0,065	0,080	0,095	29 (10 – 48)
S11	E	0,10	0,30	0,026	0,034	0,050	0,070	0,085	0,10	90 (70 – 115)
S12	E	0,10	0,30	0,026	0,034	0,050	0,070	0,085	0,10	70 (50 – 90)
S13	E	0,10	0,25	0,022	0,030	0,044	0,060	0,075	0,085	60 (44 – 75)
H5	M/A/D	0,050	0,30	0,014	0,018	0,028	0,036	0,046	0,055	65 (45 – 85)
H8	M/A/D	0,050	0,25	0,0095	0,013	0,019	0,026	0,032	0,038	70 (50 – 95)
H11	M/A/D	0,050	0,30	0,014	0,018	0,028	0,036	0,046	0,055	85 (55 – 110)
H12	M/A/D	0,050	0,25	0,0095	0,013	0,019	0,026	0,032	0,038	85 (60 – 110)
H21	M/A/D	0,050	0,25	0,0095	0,013	0,019	0,026	0,032	0,038	70 (50 – 95)
TS1	A/D	0,10	0,30	0,026	0,034	0,050	0,070	0,085	0,10	475 (425 – 520)
TP1	A/D	0,10	0,30	0,026	0,034	0,050	0,070	0,085	0,10	475 (425 – 520)
GR1	A/D	0,10	0,30	0,026	0,034	0,050	0,070	0,085	0,10	475 (425 – 520)

For cutting data recalculations, see page 411-418.

SMG = Seco material group

Coolant = A=air D=dry E=emulsion M=mist spray

v_c = m/min

f_z = mm

a_p (mm)/DC (mm)= factor

a_e (mm)/DC (mm)= factor

All cutting data are target values

Cutting data – JS509 Chamfering

SMG		a _e /DC	a _p /DC	f _z						
				3	4	6	8	10	12	
P1	M/A/D/E	0,10	0,30	0,017	0,022	0,034	0,044	0,055	0,065	310 (265 – 350)
P2	M/A/D/E	0,10	0,30	0,017	0,022	0,034	0,046	0,055	0,070	300 (260 – 340)
P3	M/A/D/E	0,10	0,30	0,016	0,022	0,032	0,044	0,055	0,065	260 (225 – 295)
P4	M/A/D/E	0,10	0,30	0,016	0,022	0,032	0,042	0,055	0,065	225 (195 – 260)
P5	M/A/D/E	0,10	0,30	0,016	0,020	0,032	0,042	0,050	0,060	220 (190 – 250)
P6	M/A/D/E	0,10	0,30	0,015	0,020	0,030	0,042	0,050	0,060	250 (215 – 280)
P7	M/A/D/E	0,10	0,30	0,015	0,020	0,030	0,042	0,050	0,060	235 (205 – 265)
P8	M/A/D/E	0,10	0,30	0,016	0,022	0,032	0,044	0,055	0,065	215 (190 – 245)
P11	M/A/D/E	0,10	0,30	0,015	0,020	0,030	0,042	0,050	0,060	225 (195 – 255)
P12	M/A/D/E	0,10	0,25	0,0085	0,011	0,017	0,022	0,028	0,034	140 (120 – 160)
M1	E/M/A	0,10	0,30	0,017	0,022	0,034	0,046	0,055	0,070	180 (145 – 215)
M2	E/M/A	0,10	0,30	0,016	0,020	0,032	0,042	0,050	0,060	145 (120 – 175)
M3	E/M/A	0,10	0,30	0,016	0,020	0,032	0,042	0,050	0,060	95 (65 – 125)
M4	E/M/A	0,10	0,20	0,013	0,017	0,026	0,034	0,044	0,050	65 (46 – 90)
M5	E/M/A	0,10	0,20	0,013	0,017	0,026	0,034	0,044	0,050	55 (39 – 75)
K1	A/D/M/E	0,10	0,30	0,017	0,022	0,034	0,046	0,055	0,070	305 (260 – 345)
K2	A/D/M/E	0,10	0,30	0,016	0,020	0,032	0,042	0,050	0,060	265 (230 – 300)
K3	A/D/M/E	0,10	0,30	0,016	0,020	0,032	0,042	0,050	0,060	225 (195 – 255)
K4	A/D/M/E	0,10	0,30	0,016	0,020	0,032	0,042	0,050	0,060	215 (185 – 245)
K5	A/D/M/E	0,10	0,30	0,014	0,019	0,028	0,038	0,046	0,055	130 (115 – 145)
K6	A/D/M/E	0,10	0,30	0,016	0,020	0,032	0,042	0,050	0,060	190 (165 – 215)
K7	A/D/M/E	0,10	0,30	0,014	0,019	0,028	0,038	0,046	0,055	165 (145 – 190)
N1	E/M/A	0,10	0,30	0,016	0,020	0,032	0,042	0,050	0,060	740 (660 – 810)
N2	E/M/A	0,10	0,30	0,016	0,020	0,032	0,042	0,050	0,060	475 (425 – 520)
N3	E/M/A	0,10	0,30	0,016	0,020	0,032	0,042	0,050	0,060	315 (285 – 345)
N11	E/M/A	0,10	0,30	0,016	0,020	0,032	0,042	0,050	0,060	420 (380 – 460)
S1	E	0,10	0,30	0,0085	0,011	0,017	0,022	0,028	0,034	65 (21 – 105)
S2	E	0,10	0,30	0,0085	0,011	0,017	0,022	0,028	0,034	50 (17 – 85)
S3	E	0,10	0,30	0,0080	0,010	0,016	0,020	0,026	0,030	44 (15 – 75)
S11	E	0,10	0,30	0,016	0,020	0,032	0,042	0,050	0,060	145 (105 – 180)
S12	E	0,10	0,30	0,016	0,020	0,032	0,042	0,050	0,060	110 (80 – 140)
S13	E	0,10	0,25	0,013	0,018	0,026	0,036	0,044	0,050	85 (60 – 105)
H5	M/A/D	0,050	0,30	0,0060	0,0080	0,012	0,016	0,020	0,024	100 (70 – 125)
H8	M/A/D	0,050	0,25	0,0040	0,0055	0,0080	0,011	0,013	0,016	95 (65 – 125)
H11	M/A/D	0,050	0,30	0,0060	0,0080	0,012	0,016	0,020	0,024	125 (85 – 160)
H12	M/A/D	0,050	0,25	0,0040	0,0055	0,0080	0,011	0,013	0,016	110 (75 – 145)
H21	M/A/D	0,050	0,25	0,0040	0,0055	0,0080	0,011	0,013	0,016	95 (65 – 125)
TS1	A/D	0,10	0,30	0,016	0,020	0,032	0,042	0,050	0,060	740 (660 – 810)
TP1	A/D	0,10	0,30	0,016	0,020	0,032	0,042	0,050	0,060	740 (660 – 810)
GR1	A/D	0,10	0,30	0,016	0,020	0,032	0,042	0,050	0,060	740 (660 – 810)

For cutting data recalculations, see page 411-418.

SMG = Seco material group

Coolant = A=air D=dry E=emulsion M=mist spray

v_c = m/min

f_z = mm

a_p (mm)/DC (mm)= factor

a_e (mm)/DC (mm)= factor

All cutting data are target values

Cutting data – JH910 Slot milling

SMG	a _p /DC	f _z														v _c	
		2	3	4	5	6	7	8	9	10	11	12	13	16	20		
P1	M/E/A	0,30	0,010	0,015	0,020	0,026	0,030	0,036	0,040	0,046	0,050	0,055	0,060	0,065	0,080	0,10	255 (225 – 285)
P2	M/E/A	0,30	0,010	0,015	0,020	0,026	0,030	0,036	0,040	0,046	0,050	0,055	0,060	0,065	0,080	0,10	250 (220 – 275)
P3	M/E/A	0,30	0,010	0,015	0,020	0,026	0,030	0,036	0,040	0,046	0,050	0,055	0,060	0,065	0,080	0,10	215 (190 – 240)
P4	M/E/A	0,30	0,010	0,015	0,020	0,026	0,030	0,036	0,040	0,046	0,050	0,055	0,060	0,065	0,080	0,10	190 (170 – 210)
P5	M/E/A	0,30	0,010	0,015	0,020	0,026	0,030	0,036	0,040	0,046	0,050	0,055	0,060	0,065	0,080	0,10	180 (160 – 200)
P6	M/E/A	0,30	0,010	0,015	0,020	0,026	0,030	0,036	0,040	0,046	0,050	0,055	0,060	0,065	0,080	0,10	200 (180 – 225)
P7	M/E/A	0,30	0,010	0,015	0,020	0,026	0,030	0,036	0,040	0,046	0,050	0,055	0,060	0,065	0,080	0,10	190 (170 – 210)
P8	M/E/A	0,30	0,010	0,015	0,020	0,026	0,030	0,036	0,040	0,046	0,050	0,055	0,060	0,065	0,080	0,10	180 (160 – 200)
P11	M/E/A	0,30	0,010	0,015	0,020	0,026	0,030	0,036	0,040	0,046	0,050	0,055	0,060	0,065	0,080	0,10	185 (165 – 205)
P12	M/E/A	0,20	0,010	0,015	0,020	0,026	0,030	0,036	0,040	0,046	0,050	0,055	0,060	0,065	0,080	0,10	110 (100 – 125)
M1	M/E/A	0,10	0,010	0,015	0,020	0,026	0,030	0,036	0,040	0,046	0,050	0,055	0,060	0,065	0,080	0,10	120 (105 – 130)
M2	M/E/A	0,10	0,010	0,015	0,020	0,026	0,030	0,036	0,040	0,046	0,050	0,055	0,060	0,065	0,080	0,10	95 (85 – 105)
M3	M/E/A	0,095	0,010	0,015	0,020	0,026	0,030	0,036	0,040	0,046	0,050	0,055	0,060	0,065	0,080	0,10	60 (50 – 70)
M4	M/E/A	0,075	0,010	0,015	0,020	0,026	0,030	0,036	0,040	0,046	0,050	0,055	0,060	0,065	0,080	0,10	46 (38 – 55)
M5	M/E/A	0,075	0,010	0,015	0,020	0,026	0,030	0,036	0,040	0,046	0,050	0,055	0,060	0,065	0,080	0,10	38 (32 – 45)
K1	A/E	0,30	0,010	0,015	0,020	0,026	0,030	0,036	0,040	0,046	0,050	0,055	0,060	0,065	0,080	0,10	175 (150 – 200)
K2	A/E	0,30	0,010	0,015	0,020	0,026	0,030	0,036	0,040	0,046	0,050	0,055	0,060	0,065	0,080	0,10	150 (130 – 175)
K3	A/E	0,30	0,010	0,015	0,020	0,026	0,030	0,036	0,040	0,046	0,050	0,055	0,060	0,065	0,080	0,10	130 (110 – 145)
K4	A/E	0,30	0,010	0,015	0,020	0,026	0,030	0,036	0,040	0,046	0,050	0,055	0,060	0,065	0,080	0,10	125 (105 – 140)
K5	A/E	0,16	0,010	0,015	0,020	0,026	0,030	0,036	0,040	0,046	0,050	0,055	0,060	0,065	0,080	0,10	150 (125 – 175)
K6	A/E	0,16	0,010	0,015	0,020	0,026	0,030	0,036	0,040	0,046	0,050	0,055	0,060	0,065	0,080	0,10	220 (185 – 260)
K7	A/E	0,16	0,010	0,015	0,020	0,026	0,030	0,036	0,040	0,046	0,050	0,055	0,060	0,065	0,080	0,10	190 (160 – 225)
S1	E/M/A	0,14	0,010	0,015	0,020	0,026	0,030	0,036	0,040	0,046	0,050	0,055	0,060	0,065	0,080	0,10	60 (50 – 75)
S2	E/M/A	0,14	0,010	0,015	0,020	0,026	0,030	0,036	0,040	0,046	0,050	0,055	0,060	0,065	0,080	0,10	50 (40 – 60)
S3	E/M/A	0,080	0,010	0,015	0,020	0,026	0,030	0,036	0,040	0,046	0,050	0,055	0,060	0,065	0,080	0,10	25 (20 – 30)
S11	E/M/A	0,25	0,010	0,015	0,020	0,026	0,030	0,036	0,040	0,046	0,050	0,055	0,060	0,065	0,080	0,10	100 (85 – 110)
S12	E/M/A	0,25	0,010	0,015	0,020	0,026	0,030	0,036	0,040	0,046	0,050	0,055	0,060	0,065	0,080	0,10	75 (65 – 85)
S13	E/M/A	0,20	0,010	0,015	0,020	0,026	0,030	0,036	0,040	0,046	0,050	0,055	0,060	0,065	0,080	0,10	60 (50 – 65)
TP1	A	0,25	0,012	0,018	0,024	0,030	0,036	0,042	0,048	0,055	0,060	0,065	0,070	0,080	0,095	0,12	150 (125 – 175)
GR1	A	0,35	0,014	0,022	0,028	0,036	0,042	0,050	0,055	0,065	0,070	0,080	0,085	0,090	0,11	0,14	600 (500 – 700)

For cutting data recalculations, see page 411-418.

SMG = Seco material group

Coolant = A=air D=dry E=emulsion M=mist spray

v_c = m/min

f_z = mm

a_p (mm)/DC (mm) = factor

All cutting data are target values

Cutting data – JH910 Side milling roughing

SMG		a _e /DC	a _p /DC	f _z														v _c	
				2	3	4	5	6	7	8	9	10	11	12	13	16	20		
P1	M/E/A	0,040	1,0	0,020	0,030	0,040	0,050	0,060	0,070	0,080	0,090	0,10	0,11	0,12	0,13	0,16	0,20	455 (405 – 510)	
P2	M/E/A	0,040	1,0	0,020	0,030	0,040	0,050	0,060	0,070	0,080	0,090	0,10	0,11	0,12	0,13	0,16	0,20	445 (395 – 495)	
P3	M/E/A	0,040	1,0	0,020	0,030	0,040	0,050	0,060	0,070	0,080	0,090	0,10	0,11	0,12	0,13	0,16	0,20	385 (340 – 425)	
P4	M/E/A	0,040	1,0	0,020	0,030	0,040	0,050	0,060	0,070	0,080	0,090	0,10	0,11	0,12	0,13	0,16	0,20	335 (300 – 375)	
P5	M/E/A	0,040	1,0	0,020	0,030	0,040	0,050	0,060	0,070	0,080	0,090	0,10	0,11	0,12	0,13	0,16	0,20	320 (285 – 360)	
P6	M/E/A	0,040	1,0	0,020	0,030	0,040	0,050	0,060	0,070	0,080	0,090	0,10	0,11	0,12	0,13	0,16	0,20	360 (320 – 400)	
P7	M/E/A	0,040	1,0	0,020	0,030	0,040	0,050	0,060	0,070	0,080	0,090	0,10	0,11	0,12	0,13	0,16	0,20	340 (305 – 380)	
P8	M/E/A	0,040	1,0	0,020	0,030	0,040	0,050	0,060	0,070	0,080	0,090	0,10	0,11	0,12	0,13	0,16	0,20	320 (285 – 360)	
P11	M/E/A	0,040	1,0	0,020	0,030	0,040	0,050	0,060	0,070	0,080	0,090	0,10	0,11	0,12	0,13	0,16	0,20	330 (295 – 370)	
P12	M/E/A	0,040	0,80	0,020	0,030	0,040	0,050	0,060	0,070	0,080	0,090	0,10	0,11	0,12	0,13	0,16	0,20	195 (175 – 220)	
M1	M/E/A	0,040	1,0	0,020	0,030	0,040	0,050	0,060	0,070	0,080	0,090	0,10	0,11	0,12	0,13	0,16	0,20	200 (180 – 220)	
M2	M/E/A	0,040	1,0	0,020	0,030	0,040	0,050	0,060	0,070	0,080	0,090	0,10	0,11	0,12	0,13	0,16	0,20	160 (145 – 180)	
M3	M/E/A	0,030	0,80	0,020	0,030	0,040	0,050	0,060	0,070	0,080	0,090	0,10	0,11	0,12	0,13	0,16	0,20	110 (90 – 125)	
M4	M/E/A	0,030	0,60	0,020	0,030	0,040	0,050	0,060	0,070	0,080	0,090	0,10	0,11	0,12	0,13	0,16	0,20	80 (70 – 95)	
M5	M/E/A	0,030	0,60	0,020	0,030	0,040	0,050	0,060	0,070	0,080	0,090	0,10	0,11	0,12	0,13	0,16	0,20	70 (55 – 80)	
K1	A/E	0,040	1,0	0,020	0,030	0,040	0,050	0,060	0,070	0,080	0,090	0,10	0,11	0,12	0,13	0,16	0,20	315 (270 – 360)	
K2	A/E	0,040	1,0	0,020	0,030	0,040	0,050	0,060	0,070	0,080	0,090	0,10	0,11	0,12	0,13	0,16	0,20	270 (235 – 310)	
K3	A/E	0,040	1,0	0,020	0,030	0,040	0,050	0,060	0,070	0,080	0,090	0,10	0,11	0,12	0,13	0,16	0,20	230 (195 – 265)	
K4	A/E	0,040	1,0	0,020	0,030	0,040	0,050	0,060	0,070	0,080	0,090	0,10	0,11	0,12	0,13	0,16	0,20	220 (190 – 250)	
K5	A/E	0,030	0,80	0,020	0,030	0,040	0,050	0,060	0,070	0,080	0,090	0,10	0,11	0,12	0,13	0,16	0,20	280 (230 – 325)	
K6	A/E	0,030	0,80	0,020	0,030	0,040	0,050	0,060	0,070	0,080	0,090	0,10	0,11	0,12	0,13	0,16	0,20	415 (345 – 480)	
K7	A/E	0,030	0,80	0,020	0,030	0,040	0,050	0,060	0,070	0,080	0,090	0,10	0,11	0,12	0,13	0,16	0,20	355 (295 – 415)	
S1	E/M/A	0,030	0,70	0,020	0,030	0,040	0,050	0,060	0,070	0,080	0,090	0,10	0,11	0,12	0,13	0,16	0,20	115 (90 – 140)	
S2	E/M/A	0,030	0,70	0,020	0,030	0,040	0,050	0,060	0,070	0,080	0,090	0,10	0,11	0,12	0,13	0,16	0,20	95 (75 – 110)	
S3	E/M/A	0,020	0,50	0,016	0,024	0,032	0,040	0,048	0,055	0,065	0,070	0,080	0,090	0,095	0,10	0,13	0,16	50 (40 – 60)	
S11	E/M/A	0,040	1,0	0,020	0,030	0,040	0,050	0,060	0,070	0,080	0,090	0,10	0,11	0,12	0,13	0,16	0,20	175 (150 – 195)	
S12	E/M/A	0,040	1,0	0,020	0,030	0,040	0,050	0,060	0,070	0,080	0,090	0,10	0,11	0,12	0,13	0,16	0,20	135 (115 – 150)	
S13	E/M/A	0,040	0,90	0,020	0,030	0,040	0,050	0,060	0,070	0,080	0,090	0,10	0,11	0,12	0,13	0,16	0,20	105 (90 – 115)	
TP1	A	0,15	1,0	0,020	0,030	0,040	0,050	0,060	0,070	0,080	0,090	0,10	0,11	0,12	0,13	0,15	0,17	205 (170 – 240)	
GR1	A	0,50	1,0	0,024	0,036	0,048	0,060	0,070	0,085	0,095	0,11	0,12	0,13	0,14	0,15	0,18	0,20	610 (510 – 710)	

For cutting data recalculations, see page 411-418.

SMG = Seco material group

Coolant = A=air D=dry E=emulsion M=mist spray

v_c = m/min

f_z = mm

a_p (mm)/DC (mm)= factor

a_e (mm)/DC (mm)= factor

All cutting data are target values

Cutting data – JH930 Side milling semi finishing

SMG		a _e /DC	a _p /DC	f _z						
				6	8	10	12	16	20	
P1	M/E/A	0,040	0,70	0,065	0,085	0,11	0,13	0,16	0,18	460 (385 – 520)
P2	M/E/A	0,040	0,70	0,065	0,090	0,11	0,13	0,16	0,19	445 (375 – 510)
P3	M/E/A	0,040	0,70	0,065	0,085	0,11	0,12	0,15	0,18	385 (325 – 435)
P4	M/E/A	0,040	0,70	0,060	0,080	0,10	0,12	0,15	0,17	345 (290 – 390)
P5	M/E/A	0,040	0,70	0,060	0,080	0,10	0,12	0,15	0,17	330 (275 – 370)
P6	M/E/A	0,040	0,70	0,060	0,080	0,10	0,12	0,15	0,17	370 (310 – 415)
P7	M/E/A	0,040	0,70	0,060	0,080	0,10	0,12	0,15	0,17	350 (290 – 395)
P8	M/E/A	0,040	0,70	0,065	0,085	0,11	0,12	0,15	0,18	325 (270 – 365)
P11	M/E/A	0,040	0,70	0,060	0,080	0,10	0,12	0,15	0,17	340 (285 – 380)
P12	M/E/A	0,040	0,50	0,040	0,050	0,065	0,075	0,095	0,11	215 (180 – 245)
K1	E/M/A	0,040	0,70	0,060	0,080	0,10	0,12	0,15	0,17	265 (210 – 320)
K2	E/M/A	0,040	0,70	0,055	0,075	0,090	0,11	0,13	0,15	235 (185 – 280)
K3	E/M/A	0,040	0,70	0,055	0,075	0,090	0,11	0,13	0,15	200 (160 – 235)
K4	E/M/A	0,040	0,70	0,055	0,075	0,090	0,11	0,13	0,15	190 (150 – 225)
K5	E/M/A	0,030	0,50	0,060	0,080	0,10	0,12	0,15	0,17	215 (160 – 270)
K6	E/M/A	0,030	0,50	0,070	0,090	0,11	0,13	0,17	0,19	315 (235 – 395)
K7	E/M/A	0,030	0,50	0,060	0,080	0,10	0,12	0,15	0,17	275 (210 – 345)
S1	E/M/A	0,030	0,45	0,055	0,075	0,090	0,11	0,14	0,16	85 (65 – 110)
S2	E/M/A	0,030	0,45	0,055	0,075	0,090	0,11	0,14	0,16	70 (55 – 90)
S3	E/M/A	0,020	0,70	0,055	0,075	0,090	0,11	0,13	0,15	42 (32 – 55)
S11	E/M/A	0,040	0,70	0,060	0,080	0,10	0,12	0,15	0,17	165 (140 – 195)
S12	E/M/A	0,040	0,70	0,060	0,080	0,10	0,12	0,15	0,17	125 (105 – 150)
S13	E/M/A	0,040	0,60	0,055	0,070	0,090	0,10	0,13	0,15	100 (85 – 120)
H3	M/A	0,020	0,50	0,018	0,024	0,030	0,036	0,044	0,050	60 (43 – 75)
H5	M/A	0,030	0,50	0,024	0,032	0,040	0,048	0,060	0,070	265 (215 – 320)
H7	M/A	0,020	0,50	0,018	0,024	0,030	0,036	0,044	0,050	60 (43 – 75)
H8	M/A	0,030	0,45	0,017	0,022	0,028	0,034	0,042	0,048	275 (220 – 325)
H11	M/A	0,030	0,50	0,024	0,032	0,040	0,048	0,060	0,070	340 (270 – 405)
H12	M/A	0,040	0,45	0,024	0,030	0,038	0,046	0,055	0,065	300 (240 – 360)
H21	M/A	0,030	0,45	0,017	0,022	0,028	0,034	0,042	0,048	275 (220 – 325)
H31	M/A	0,030	0,50	0,024	0,032	0,040	0,048	0,060	0,070	165 (130 – 195)

For cutting data recalculations, see page 411-418.

SMG = Seco material group

Coolant = A=air D=dry E=emulsion M=mist spray

v_c = m/min

f_z = mm

a_p (mm)/DC (mm)= factor

a_e (mm)/DC (mm)= factor

All cutting data are target values

Cutting data – JH930 Side milling roughing

SMG		a _e /DC	a _p /DC	f _z							v _c
				6	8	10	12	16	20		
P1	M/E/A	0,040	0,70	0,065	0,085	0,11	0,13	0,16	0,18	440 (370 – 490)	
P2	M/E/A	0,040	0,70	0,065	0,090	0,11	0,13	0,16	0,19	430 (360 – 480)	
P3	M/E/A	0,040	0,70	0,060	0,085	0,10	0,12	0,15	0,18	375 (320 – 420)	
P4	M/E/A	0,040	0,70	0,060	0,080	0,10	0,12	0,15	0,17	330 (280 – 370)	
P5	M/E/A	0,040	0,70	0,060	0,080	0,10	0,12	0,15	0,17	315 (270 – 350)	
P6	M/E/A	0,040	0,70	0,060	0,080	0,10	0,12	0,15	0,17	355 (300 – 390)	
P7	M/E/A	0,040	0,70	0,060	0,080	0,10	0,12	0,15	0,17	335 (280 – 370)	
P8	M/E/A	0,040	0,70	0,060	0,085	0,10	0,12	0,15	0,18	315 (270 – 350)	
P11	M/E/A	0,040	0,70	0,060	0,080	0,10	0,12	0,15	0,17	325 (280 – 360)	
P12	M/E/A	0,040	0,50	0,038	0,050	0,065	0,075	0,095	0,11	205 (180 – 230)	
K1	E/M/A	0,040	0,70	0,060	0,080	0,10	0,12	0,15	0,17	255 (210 – 300)	
K2	E/M/A	0,040	0,70	0,055	0,075	0,090	0,11	0,13	0,15	225 (180 – 260)	
K3	E/M/A	0,040	0,70	0,055	0,075	0,090	0,11	0,13	0,15	190 (160 – 220)	
K4	E/M/A	0,040	0,70	0,055	0,075	0,090	0,11	0,13	0,15	180 (150 – 210)	
K5	E/M/A	0,030	0,50	0,060	0,080	0,10	0,12	0,15	0,17	205 (160 – 250)	
K6	E/M/A	0,030	0,50	0,065	0,090	0,11	0,13	0,16	0,19	300 (230 – 370)	
K7	E/M/A	0,030	0,50	0,060	0,080	0,10	0,12	0,15	0,17	260 (200 – 320)	
S1	E/M/A	0,030	0,44	0,055	0,070	0,090	0,11	0,13	0,15	80 (62 – 100)	
S2	E/M/A	0,030	0,44	0,055	0,070	0,090	0,11	0,13	0,15	65 (50 – 82)	
S3	E/M/A	0,020	0,70	0,055	0,070	0,090	0,11	0,13	0,15	41 (31 – 50)	
S11	E/M/A	0,040	0,70	0,060	0,080	0,10	0,12	0,15	0,17	160 (140 – 180)	
S12	E/M/A	0,040	0,70	0,060	0,080	0,10	0,12	0,15	0,17	120 (110 – 140)	
S13	E/M/A	0,040	0,60	0,050	0,070	0,085	0,10	0,13	0,15	95 (82 – 110)	
H5	M/A	0,030	0,50	0,024	0,032	0,040	0,048	0,060	0,070	250 (210 – 300)	
H8	M/A	0,030	0,44	0,017	0,022	0,028	0,034	0,042	0,048	260 (210 – 300)	
H11	M/A	0,030	0,50	0,024	0,032	0,040	0,048	0,060	0,070	320 (260 – 380)	
H12	M/A	0,040	0,44	0,022	0,030	0,038	0,044	0,055	0,065	280 (230 – 330)	
H21	M/A	0,030	0,44	0,017	0,022	0,028	0,034	0,042	0,048	260 (210 – 300)	
H31	M/A	0,030	0,50	0,024	0,032	0,040	0,048	0,060	0,070	155 (130 – 180)	

For cutting data recalculations, see page 411-418.

SMG = Seco material group

Coolant = A=air D=dry E=emulsion M=mist spray

v_c = m/min

f_z = mm

a_p (mm)/DC (mm)= factor

a_e (mm)/DC (mm)= factor

All cutting data are target values

JH970 – High speed – Universal – Ball nose – 2 Flutes – Cylindrical



Tolerances:
 DMM= h5
 DC= -0,02/-0,04 mm
 RE= ±0,01 mm
 Regrind possible if DC is ≥Ø6

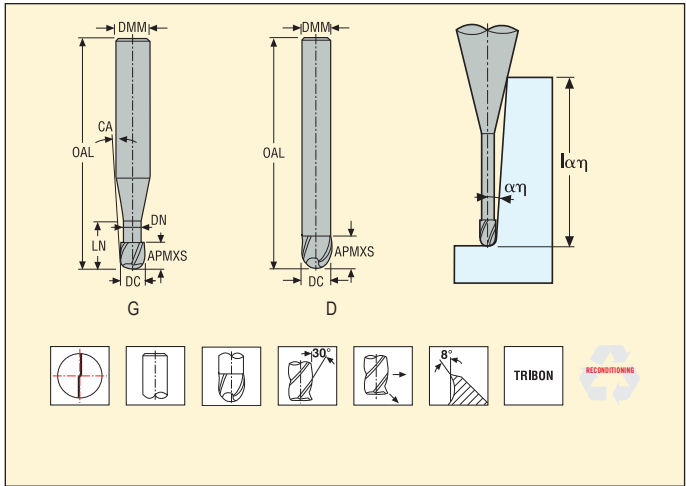

Ordering and Product No.	Designation	Length index	Tool shape	Dimensions in mm							PCEDC	Max. cut depth rel. to $\alpha\eta$ ($I\alpha\eta$, ref)*					
				DC	DMM	APMXS	OAL	LN	DN	CA		WDX0	WDX05	WDX1	WDX15	WDX2	WDX3
02452881	970021-TRIBON	1	G	2,0	3	3,0	50	10	1,9	2,5	2	10,0	11,0	11,5	12,1	12,8	∞
02452882	970031-TRIBON	1	D	3,0	3	4,5	50	–	–	–	2	4,5	∞	∞	∞	∞	∞
02452883	970041-TRIBON	1	D	4,0	4	6,0	60	–	–	–	2	6,0	∞	∞	∞	∞	∞
02452884	970051-TRIBON	1	D	5,0	5	7,5	60	–	–	–	2	7,5	∞	∞	∞	∞	∞
02452885	970061-TRIBON	1	D	6,0	6	9,0	75	–	–	–	2	9,0	∞	∞	∞	∞	∞
02452886	970020-TRIBON	2	G	2,0	6	3,0	60	4	1,9	8,0	2	4,0	4,7	4,9	5,1	5,4	6,0
02452887	970025-TRIBON	2	G	2,5	6	4,0	60	5	2,4	7,5	2	5,0	5,7	6,0	6,2	6,5	7,3
02452888	970030-TRIBON	2	G	3,0	6	4,5	60	6	2,8	5,5	2	6,0	7,4	7,8	8,3	9,0	10,6
02452889	970035-TRIBON	2	G	3,5	6	5,0	60	7	3,2	4,5	2	7,0	8,8	9,4	10,0	10,7	12,8
02452890	970040-TRIBON	2	G	4,0	6	6,0	60	8	3,7	3,0	2	8,0	10,8	11,9	13,3	15,2	∞
02452891	970050-TRIBON	2	G	5,0	6	7,5	60	10	4,6	2,0	2	10,0	13,6	15,0	16,8	∞	∞
02452892	970060-TRIBON	2	G	6,0	8	9,0	75	12	5,6	2,5	2	12,0	15,8	17,4	19,4	22,2	∞
02452893	970080-TRIBON	2	D	8,0	8	12,0	75	–	–	–	2	12,0	∞	∞	∞	∞	∞
02452894	970100-TRIBON	2	D	10,0	10	15,0	80	–	–	–	2	15,0	∞	∞	∞	∞	∞
02452895	970120-TRIBON	2	D	12,0	12	18,0	90	–	–	–	2	18,0	∞	∞	∞	∞	∞
02452896	970160-TRIBON	2	D	16,0	16	24,0	100	–	–	–	2	24,0	∞	∞	∞	∞	∞
02452899	970L020-TRIBON	3	G	2,0	6	3,0	80	4	1,9	8,0	2	4,0	4,7	4,9	5,1	5,4	6,0
02452900	970L030-TRIBON	3	G	3,0	6	4,5	80	6	2,8	5,5	2	6,0	7,4	7,8	8,3	9,0	10,6
02452901	970L040-TRIBON	3	G	4,0	6	6,0	80	8	3,7	3,0	2	8,0	10,8	11,9	13,3	15,2	∞
02452902	970L050-TRIBON	3	G	5,0	6	7,5	100	10	4,6	2,0	2	10,0	13,6	15,0	16,8	∞	∞
02452903	970L060-TRIBON	3	G	6,0	8	9,0	100	12	5,6	2,5	2	12,0	15,8	17,4	19,4	22,2	∞
02452904	970L080-TRIBON	3	D	8,0	8	12,0	110	–	–	–	2	12,0	∞	∞	∞	∞	∞
02452905	970L100-TRIBON	3	D	10,0	10	15,0	125	–	–	–	2	15,0	∞	∞	∞	∞	∞
02452906	970L120-TRIBON	3	D	12,0	12	18,0	125	–	–	–	2	18,0	∞	∞	∞	∞	∞
02452907	970L160-TRIBON	3	D	16,0	16	24,0	150	–	–	–	2	24,0	∞	∞	∞	∞	∞

* The effective under -neck length for the various draft angles. Remark ∞ = infinity, no collision in projection length area.

Cutting data – JH970 Copy milling roughing

SMG		a _e /DC	a _p /DC	f _z										v _c
				2	3	4	5	6	8	10	12	16		
P1	M	0,35	0,070	0,040	0,060	0,080	0,10	0,12	0,16	0,20	0,24	0,32	245 (210 – 275)	
P2	M	0,35	0,070	0,040	0,060	0,080	0,10	0,12	0,16	0,20	0,24	0,32	240 (205 – 270)	
P3	M	0,35	0,070	0,040	0,060	0,080	0,10	0,12	0,16	0,20	0,24	0,32	205 (180 – 230)	
P4	M	0,35	0,070	0,040	0,060	0,080	0,10	0,12	0,16	0,20	0,24	0,32	180 (155 – 205)	
P5	M	0,35	0,070	0,040	0,060	0,080	0,10	0,12	0,16	0,20	0,24	0,32	170 (150 – 195)	
P6	M	0,35	0,070	0,040	0,060	0,080	0,10	0,12	0,16	0,20	0,24	0,32	195 (170 – 220)	
P7	M	0,35	0,070	0,040	0,060	0,080	0,10	0,12	0,16	0,20	0,24	0,32	185 (160 – 205)	
P8	M	0,35	0,070	0,040	0,060	0,080	0,10	0,12	0,16	0,20	0,24	0,32	170 (150 – 195)	
P11	M	0,35	0,070	0,040	0,060	0,080	0,10	0,12	0,16	0,20	0,24	0,32	180 (155 – 200)	
P12	M	0,35	0,055	0,032	0,048	0,065	0,080	0,10	0,13	0,16	0,20	0,26	110 (95 – 125)	
M1	M	0,17	1,0	0,020	0,030	0,040	0,050	0,060	0,080	0,10	0,12	0,16	95 (85 – 110)	
M2	M	0,17	1,0	0,020	0,030	0,040	0,050	0,060	0,080	0,10	0,12	0,16	80 (70 – 90)	
M3	M	0,13	1,0	0,022	0,032	0,042	0,055	0,065	0,085	0,11	0,13	0,16	65 (55 – 75)	
M4	M	0,13	0,80	0,020	0,030	0,040	0,050	0,060	0,080	0,10	0,12	0,14	50 (44 – 60)	
M5	M	0,13	0,80	0,020	0,030	0,040	0,050	0,060	0,080	0,10	0,12	0,14	43 (37 – 50)	
S1	E	0,15	0,065	0,040	0,060	0,080	0,10	0,12	0,16	0,20	0,24	0,30	50 (41 – 60)	
S2	E	0,15	0,065	0,040	0,060	0,080	0,10	0,12	0,16	0,20	0,24	0,30	42 (33 – 50)	
S3	E	0,12	0,060	0,038	0,055	0,075	0,095	0,11	0,15	0,19	0,22	0,28	31 (21 – 42)	
S11	E	0,35	0,14	0,012	0,018	0,024	0,030	0,036	0,048	0,060	0,070	0,095	105 (90 – 120)	
S12	E	0,35	0,14	0,012	0,018	0,024	0,030	0,036	0,048	0,060	0,070	0,095	80 (70 – 90)	
S13	E	0,35	0,12	0,012	0,018	0,024	0,030	0,036	0,048	0,060	0,070	0,095	60 (55 – 70)	

For cutting data recalculations, see page 411-418.

SMG = Seco material group

Coolant = A=air D=dry E=emulsion M=mist spray

v_c = m/min

f_z = mm

a_p (mm)/DC (mm)= factor

a_e (mm)/DC (mm)= factor

All cutting data are target values

JH980 – High feed – Universal – 2-5 Flutes – Cylindrical – Corner radius



Tolerances:
 DMM= h5
 DC= -0,02/-0,04 mm
 RE= ±0,05 mm
 CA= collision angle
 Regrind possible if DC is ≥Ø6

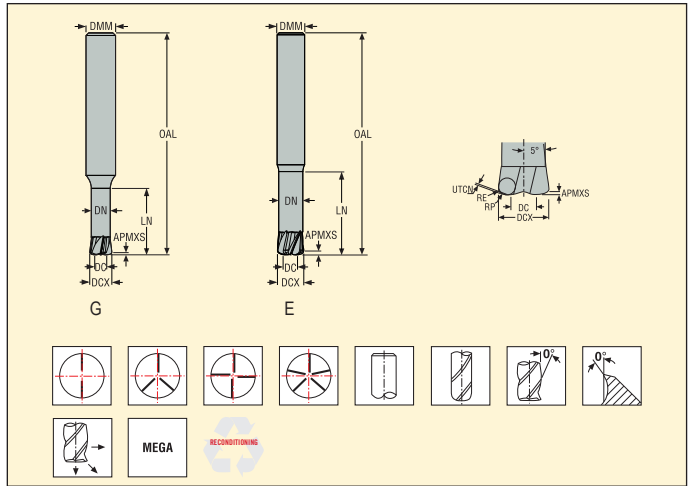

Ordering and Product No.	Designation	Length index	Tool shape	Dimensions in mm							RE	RP	UTCN	CA	CEDC	Cylindrical
				DC	DCX	DMM	APMXS	OAL	LN	DN						
02587115	980K080Z3-MEGA	1	E	4,0	8,0	8	0,4	70	12,0	3,0	0,6	0,935	0,198	-	3	■
03003384	JHF980080E1H.0Z5-MEGA	1	E	4,0	8,0	8	0,4	70	12,0	7,0	0,6	0,935	0,198	-	5	■
02587117	980K100Z3-MEGA	1	E	5,0	10,0	10	0,45	80	15,0	3,8	0,8	1,176	0,232	-	3	■
03003385	JHF980100E1H.0Z5-MEGA	1	E	5,0	10,0	10	0,45	80	15,0	8,8	0,8	1,176	0,232	-	5	■
02587118	980K120Z3-MEGA	1	E	6,0	12,0	12	0,5	80	18,0	4,6	1,0	1,417	0,266	-	3	■
03003386	JHF980120E1H.0Z5-MEGA	1	E	6,0	12,0	12	0,5	80	18,0	10,6	1,0	1,417	0,265	-	5	■
02587111	980010-MEGA	2	G	0,5	1,0	6	0,07	40	3,0	0,7	0,07	0,127	0,028	19,5	2	■
02511199	980015-MEGA	2	G	0,75	1,5	6	0,1	40	4,5	1,2	0,1	0,183	0,043	14,0	2	■
02511221	980020-MEGA	2	G	1,0	2,0	6	0,15	40	6,0	1,7	0,15	0,269	0,055	11,0	2	■
02511224	980030-MEGA	2	G	1,5	3,0	6	0,2	50	9,0	2,6	0,2	0,366	0,085	7,0	2	■
03003387	JHF980030G2H.0Z4-MEGA	2	G	1,5	3,0	6	0,2	50	9,0	2,6	0,2	0,366	0,085	7,12	4	■
02511229	980040-MEGA	2	G	2,0	4,0	6	0,25	60	12,0	3,5	0,3	0,503	0,107	4,0	2	■
03003388	JHF980040G2H.0Z4-MEGA	2	G	2,0	4,0	6	0,25	60	12,0	3,5	0,3	0,503	0,107	4,0	4	■
02511233	980050-MEGA	2	G	2,5	5,0	6	0,3	60	15,0	4,4	0,4	0,641	0,128	2,0	2	■
03003389	JHF980050G2H.0Z4-MEGA	2	G	2,5	5,0	6	0,3	60	15,0	4,4	0,4	0,641	0,128	1,77	4	■
02511314	980060-MEGA	2	G	3,0	6,0	8	0,35	60	18,0	5,2	0,5	0,778	0,15	3,0	2	■
03003390	JHF980060G2H.0Z4-MEGA	2	G	3,0	6,0	8	0,35	60	18,0	5,2	0,5	0,778	0,15	2,86	4	■
02511322	980080-MEGA	2	E	4,0	8,0	8	0,4	70	24,0	7,0	0,6	0,935	0,198	-	2	■
03003391	JHF980080E2H.0Z5-MEGA	2	E	4,0	8,0	8	0,4	70	24,0	7,0	0,6	0,935	0,198	-	5	■
02511341	980100-MEGA	2	E	5,0	10,0	10	0,45	80	30,0	8,8	0,8	1,176	0,232	-	2	■
02511342	980100Z3-MEGA	2	E	5,0	10,0	10	0,45	80	30,0	8,8	0,8	1,176	0,232	-	3	■
03003392	JHF980100E2H.0Z5-MEGA	2	E	5,0	10,0	10	0,45	80	30,0	8,8	0,8	1,176	0,232	-	5	■
02511346	980120-MEGA	2	E	6,0	12,0	12	0,5	80	36,0	10,6	1,0	1,417	0,266	-	2	■
02511347	980120Z3-MEGA	2	E	6,0	12,0	12	0,5	80	36,0	10,6	1,0	1,417	0,266	-	3	■
03003393	JHF980120E2H.0Z5-MEGA	2	E	6,0	12,0	12	0,5	80	36,0	10,6	1,0	1,417	0,265	-	5	■
02587113	980ML010-MEGA	3	G	0,5	1,0	6	0,07	40	5,0	0,7	0,07	0,127	0,028	15,5	2	■
02511219	980ML015-MEGA	3	G	0,75	1,5	6	0,1	40	7,5	1,2	0,1	0,183	0,043	10,5	2	■
02511222	980ML020-MEGA	3	G	1,0	2,0	6	0,15	40	10,0	1,7	0,15	0,269	0,055	8,0	2	■
03003394	JHF980020G3H.0Z4-MEGA	3	G	1,0	2,0	6	0,15	40	10,0	1,7	0,15	0,269	0,055	8,46	4	■
02511225	980ML030-MEGA	3	G	1,5	3,0	6	0,2	50	15,0	2,6	0,2	0,366	0,085	5,0	2	■
03003395	JHF980030G3H.0Z4-MEGA	3	G	1,5	3,0	6	0,2	50	15,0	2,6	0,2	0,366	0,085	4,79	4	■
02511231	980ML040-MEGA	3	G	2,0	4,0	6	0,25	70	20,0	3,5	0,3	0,503	0,107	2,5	2	■
03003396	JHF980040G3H.0Z4-MEGA	3	G	2,0	4,0	6	0,25	70	20,0	3,5	0,3	0,503	0,107	2,59	4	■
02511234	980ML050-MEGA	3	G	2,5	5,0	6	0,3	80	25,0	4,4	0,4	0,641	0,128	1,5	2	■
03003397	JHF980050G3H.0Z4-MEGA	3	G	2,5	5,0	6	0,3	80	25,0	4,4	0,4	0,641	0,128	1,12	4	■
02511315	980ML060-MEGA	3	G	3,0	6,0	8	0,35	80	30,0	5,2	0,5	0,778	0,15	2,0	2	■
03003398	JHF980060G3H.0Z4-MEGA	3	G	3,0	6,0	8	0,35	80	30,0	5,2	0,5	0,778	0,15	1,8	4	■

*UTCN=uncut-thickness

■ Stock standard. Subject to change refer to current price- and stock-list

JH980 - High feed - Universal - 2-5 Flutes - Cylindrical - Corner radius



Tolerances:
 DMM= h5
 DC= -0,02/-0,04 mm
 RE= ±0,05 mm
 CA= collision angle
 Regrind possible if DC is ≥06

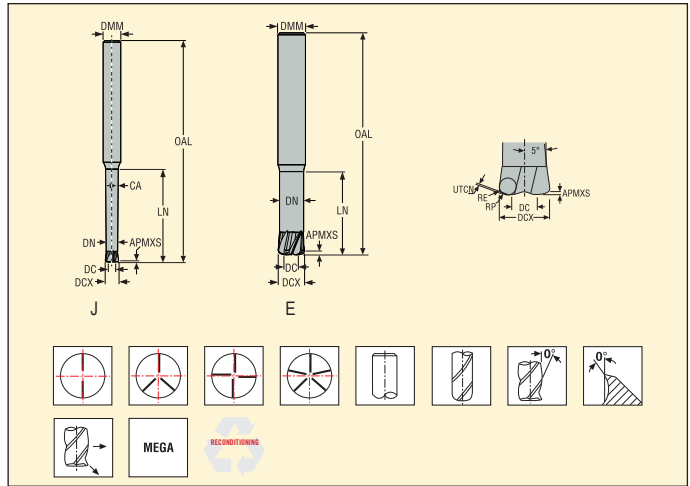

Ordering and Product No.	Designation	Length index	Tool shape	Dimensions in mm							RE	RP	UTCN	CA	NA	CEDC	Cylindrical
				DC	DCX	DMM	APMXS	OAL	LN	DN							
02511338	980ML080-MEGA	3	E	4,0	8,0	8	0,4	80	40,0	7,0	0,6	0,935	0,198	-	0,0	2	■
03003399	JHF980080E3H.0Z5-MEGA	3	E	4,0	8,0	8	0,4	80	40,0	7,0	0,6	0,935	0,198	-	0,0	5	■
02511344	980ML100-MEGA	3	E	5,0	10,0	10	0,45	90	50,0	8,8	0,8	1,176	0,232	-	0,0	2	■
03003400	JHF980100E3H.0Z5-MEGA	3	E	5,0	10,0	10	0,45	90	50,0	8,8	0,8	1,176	0,232	-	0,0	5	■
02511348	980ML120-MEGA	3	E	6,0	12,0	12	0,5	110	60,0	10,6	1,0	1,417	0,266	-	0,0	2	■
03003401	JHF980120E3H.0Z5-MEGA	3	E	6,0	12,0	12	0,5	110	60,0	10,6	1,0	1,417	0,265	-	0,0	5	■
02587114	980TL010-MEGA	4	J	0,5	1,0	6	0,07	40	7,0	0,7	0,07	0,127	0,028	13,0	0,5	2	■
02511220	980TL015-MEGA	4	J	0,75	1,5	6	0,1	40	10,5	1,2	0,1	0,183	0,043	8,5	0,5	2	■
02511223	980TL020-MEGA	4	J	1,0	2,0	6	0,15	50	14,0	1,7	0,15	0,269	0,055	6,5	0,5	2	■
02511226	980TL030-MEGA	4	J	1,5	3,0	6	0,2	60	21,0	2,6	0,2	0,366	0,085	3,5	0,5	2	■
03003402	JHF980030J4H.0Z4-MEGA	4	J	1,5	3,0	6	0,2	60	21,0	2,6	0,2	0,366	0,085	3,63	0,5	4	■
02511232	980TL040-MEGA	4	J	2,0	4,0	6	0,25	80	28,0	3,5	0,3	0,503	0,107	2,0	0,5	2	■
03003403	JHF980040J4H.0Z4-MEGA	4	J	2,0	4,0	6	0,25	80	28,0	3,5	0,3	0,503	0,107	1,93	0,5	4	■
02511240	980TL050-MEGA	4	J	2,5	5,0	6	0,3	90	35,0	4,4	0,4	0,641	0,128	1,0	0,5	2	■
03003404	JHF980050J4H.0Z4-MEGA	4	J	2,5	5,0	6	0,3	90	35,0	4,4	0,4	0,641	0,128	0,82	0,5	4	■
02511321	980TL060-MEGA	4	J	3,0	6,0	8	0,35	100	42,0	5,2	0,5	0,778	0,15	1,5	0,5	2	■
03003405	JHF980060J4H.0Z4-MEGA	4	J	3,0	6,0	8	0,35	100	42,0	5,2	0,5	0,778	0,15	1,33	0,5	4	■
02511340	980TL080-MEGA	4	E	4,0	8,0	8	0,4	100	56,0	7,0	0,6	0,935	0,198	-	0,5	2	■
03003406	JHF980080E4H.0Z5-MEGA	4	E	4,0	8,0	8	0,4	100	56,0	7,0	0,6	0,935	0,198	-	0,0	5	■
02511345	980TL100-MEGA	4	E	5,0	10,0	10	0,45	110	70,0	8,8	0,8	1,176	0,232	-	0,5	2	■
03003407	JHF980100E4H.0Z5-MEGA	4	E	5,0	10,0	10	0,45	110	70,0	8,8	0,8	1,176	0,232	-	0,0	5	■
02511349	980TL120-MEGA	4	E	6,0	12,0	12	0,5	130	84,0	10,6	1,0	1,417	0,266	-	0,5	2	■
03003408	JHF980120E4H.0Z5-MEGA	4	E	6,0	12,0	12	0,5	130	84,0	10,6	1,0	1,417	0,265	-	0,0	5	■

*UTCN=uncut-thickness

■ Stock standard. Subject to change refer to current price- and stock-list

Cutting data - JHF980 Slot milling

SMG		a _p /DC	f _z (Based on DC)											v _c
			0,5	0,75	1	1,5	2	2,5	3	4	5	6		
P1	E/M/A	0,080	0,026	0,038	0,050	0,080	0,10	0,13	0,16	0,20	0,26	0,32	325 (285 — 360)	
P2	E/M/A	0,080	0,026	0,038	0,050	0,080	0,10	0,13	0,16	0,20	0,26	0,32	315 (280 — 350)	
P3	E/M/A	0,080	0,026	0,038	0,050	0,080	0,10	0,13	0,16	0,20	0,26	0,32	270 (240 — 300)	
P4	E/M/A	0,080	0,026	0,038	0,050	0,080	0,10	0,13	0,16	0,20	0,26	0,32	240 (210 — 265)	
P5	E/M/A	0,080	0,026	0,038	0,050	0,080	0,10	0,13	0,16	0,20	0,26	0,32	230 (200 — 255)	
P6	E/M/A	0,080	0,026	0,038	0,050	0,080	0,10	0,13	0,16	0,20	0,26	0,32	255 (225 — 285)	
P7	E/M/A	0,080	0,026	0,038	0,050	0,080	0,10	0,13	0,16	0,20	0,26	0,32	240 (215 — 270)	
P8	E/M/A	0,080	0,026	0,038	0,050	0,080	0,10	0,13	0,16	0,20	0,26	0,32	230 (200 — 255)	
P11	E/M/A	0,080	0,026	0,038	0,050	0,080	0,10	0,13	0,16	0,20	0,26	0,32	235 (210 — 260)	
P12	E/M/A	0,064	0,024	0,038	0,050	0,075	0,10	0,12	0,15	0,20	0,24	0,28	145 (125 — 160)	
M1	E/M/A	0,072	0,020	0,030	0,040	0,060	0,080	0,10	0,12	0,16	0,20	0,24	155 (140 — 175)	
M2	E/M/A	0,072	0,020	0,030	0,040	0,060	0,080	0,10	0,12	0,16	0,20	0,24	125 (110 — 140)	
M3	E/M/A	0,072	0,020	0,030	0,040	0,060	0,080	0,10	0,12	0,16	0,20	0,24	95 (80 — 110)	
M4	E/M/A	0,052	0,020	0,030	0,040	0,060	0,080	0,10	0,12	0,16	0,20	0,24	75 (60 — 85)	
M5	E/M/A	0,052	0,020	0,030	0,040	0,060	0,080	0,10	0,12	0,16	0,20	0,24	60 (50 — 70)	
K1	E/M/A	0,080	0,020	0,030	0,040	0,060	0,080	0,10	0,12	0,16	0,20	0,24	180 (150 — 205)	
K2	E/M/A	0,080	0,020	0,030	0,040	0,060	0,080	0,10	0,12	0,16	0,20	0,24	155 (130 — 175)	
K3	E/M/A	0,080	0,020	0,030	0,040	0,060	0,080	0,10	0,12	0,16	0,20	0,24	130 (110 — 150)	
K4	E/M/A	0,080	0,020	0,030	0,040	0,060	0,080	0,10	0,12	0,16	0,20	0,24	125 (105 — 140)	
K5	E/M/A	0,080	0,020	0,030	0,040	0,060	0,080	0,10	0,12	0,16	0,20	0,22	125 (100 — 150)	
K6	E/M/A	0,080	0,020	0,030	0,040	0,060	0,080	0,10	0,12	0,16	0,20	0,24	190 (150 — 225)	
K7	E/M/A	0,080	0,020	0,030	0,040	0,060	0,080	0,10	0,12	0,16	0,20	0,22	165 (130 — 195)	
S1	E	0,044	0,015	0,022	0,030	0,046	0,060	0,075	0,090	0,12	0,15	0,18	50 (40 — 60)	
S2	E	0,044	0,015	0,022	0,030	0,046	0,060	0,075	0,090	0,12	0,15	0,18	41 (33 — 49)	
S3	E	0,044	0,015	0,022	0,030	0,046	0,060	0,075	0,090	0,12	0,15	0,18	30 (20 — 41)	
S11	E	0,044	0,015	0,022	0,030	0,046	0,060	0,075	0,090	0,12	0,15	0,18	150 (130 — 170)	
S12	E	0,044	0,015	0,022	0,030	0,046	0,060	0,075	0,090	0,12	0,15	0,18	115 (100 — 130)	
S13	E	0,038	0,014	0,022	0,028	0,042	0,055	0,070	0,085	0,11	0,14	0,17	90 (80 — 105)	
H5	M/A/D	0,072	0,020	0,030	0,040	0,060	0,080	0,10	0,12	0,16	0,20	0,24	95 (80 — 110)	
H8	M/A/D	0,064	0,020	0,030	0,040	0,060	0,080	0,10	0,12	0,16	0,20	0,24	100 (85 — 115)	
H21	M/A/D	0,064	0,020	0,030	0,040	0,060	0,080	0,10	0,12	0,16	0,20	0,24	100 (85 — 115)	
H31	M/A/D	0,064	0,019	0,028	0,038	0,055	0,075	0,095	0,11	0,15	0,19	0,20	75 (65 — 85)	

For cutting data recalculations, see page 411-418.

SMG = Seco material group

Coolant = A=air D=dry E=emulsion M=mist spray

v_c = m/min

f_z = mm

a_p (mm)/DC (mm)= factor

All cutting data are target values

Cutting data – JHF980 Side milling

SMG		a _e /DCX	a _p /DC	f _z (Based on DC)											v _c
				0,5	0,75	1	1,5	2	2,5	3	4	5	6		
P1	E/M/A	0,30	0,080	0,055	0,085	0,11	0,17	0,22	0,28	0,34	0,38	0,55	—	425 (380 — 475)	
P2	E/M/A	0,30	0,080	0,055	0,085	0,11	0,17	0,22	0,28	0,34	0,38	—	0,46	415 (370 — 460)	
P3	E/M/A	0,30	0,080	0,055	0,080	0,11	0,16	0,22	0,26	0,32	0,36	0,55	—	360 (320 — 400)	
P4	E/M/A	0,30	0,080	0,050	0,080	0,10	0,16	0,20	0,26	0,32	0,36	0,44	0,42	320 (285 — 355)	
P5	E/M/A	0,30	0,080	0,050	0,075	0,10	0,15	0,20	0,26	0,30	0,34	—	0,42	305 (270 — 340)	
P6	E/M/A	0,30	0,080	0,050	0,075	0,10	0,15	0,20	0,26	0,30	0,34	—	—	345 (305 — 380)	
P7	E/M/A	0,30	0,080	0,050	0,075	0,10	0,15	0,20	0,26	0,30	0,34	—	0,42	325 (290 — 360)	
P8	E/M/A	0,30	0,080	0,055	0,080	0,11	0,16	0,22	0,26	0,32	0,36	0,55	—	305 (270 — 335)	
P11	E/M/A	0,30	0,080	0,050	0,075	0,10	0,15	0,20	0,26	0,30	0,34	0,50	—	315 (280 — 350)	
P12	E/M/A	0,30	0,080	0,032	0,050	0,065	0,10	0,13	0,16	0,20	0,22	0,28	—	205 (180 — 225)	
M1	E/M/A	0,30	0,072	0,042	0,065	0,085	0,13	0,17	0,20	0,26	0,30	0,38	—	205 (180 — 230)	
M2	E/M/A	0,30	0,072	0,038	0,055	0,075	0,11	0,15	0,19	0,22	0,28	0,38	—	170 (150 — 190)	
M3	E/M/A	0,30	0,072	0,038	0,055	0,075	0,11	0,15	0,19	0,22	0,28	—	0,34	130 (110 — 150)	
M4	E/M/A	0,30	0,072	0,034	0,050	0,065	0,10	0,13	0,17	0,20	0,24	0,34	—	100 (85 — 115)	
M5	E/M/A	0,30	0,072	0,034	0,050	0,065	0,10	0,13	0,17	0,20	0,24	—	0,30	85 (70 — 95)	
K1	E/M/A	0,30	0,080	0,042	0,060	0,085	0,12	0,17	0,20	0,24	0,28	—	—	235 (205 — 270)	
K2	E/M/A	0,30	0,080	0,038	0,055	0,075	0,11	0,15	0,19	0,22	0,26	—	0,30	210 (180 — 240)	
K3	E/M/A	0,30	0,080	0,038	0,055	0,075	0,11	0,15	0,19	0,22	0,26	0,38	—	180 (150 — 205)	
K4	E/M/A	0,30	0,080	0,038	0,055	0,075	0,11	0,15	0,19	0,22	0,26	0,38	—	170 (145 — 195)	
K5	E/M/A	0,30	0,080	0,030	0,046	0,060	0,090	0,12	0,15	0,18	0,20	0,30	—	180 (145 — 215)	
K6	E/M/A	0,30	0,080	0,034	0,050	0,070	0,10	0,14	0,17	0,20	0,24	—	0,28	260 (205 — 310)	
K7	E/M/A	0,30	0,080	0,030	0,046	0,060	0,090	0,12	0,15	0,18	0,20	—	0,26	230 (185 — 275)	
H5	M/A/D	0,30	0,072	0,036	0,055	0,075	0,11	0,15	0,18	0,22	0,26	0,34	—	130 (110 — 150)	
H8	M/A/D	0,30	0,072	0,028	0,042	0,055	0,085	0,11	0,14	0,17	0,20	—	0,24	135 (115 — 160)	
H21	M/A/D	0,30	0,072	0,028	0,042	0,055	0,085	0,11	0,14	0,17	0,20	0,26	—	135 (115 — 160)	
H31	M/A/D	0,30	0,072	0,022	0,034	0,044	0,065	0,090	0,11	0,13	0,16	0,22	—	110 (90 — 125)	

For cutting data recalculations, see page 411-418.

SMG = Seco material group

Coolant = A=air D=dry E=emulsion M=mist spray

v_c = m/min

f_z = mm

a_p (mm)/DC (mm)= factor

a_e (mm)/DC (mm)= factor

All cutting data are target values

Cutting data - J29 Slot milling

SMG		a_p/DC	f_z				v_c
			3	4	6		
P1	E	0,50	0,24	0,26	0,28	42 (32 – 63)	
P2	E	0,50	0,24	0,26	0,30	41 (32 – 61)	
P3	E	0,50	0,24	0,25	0,28	36 (28 – 54)	
P4	E	0,50	0,22	0,24	0,26	31 (24 – 47)	
P5	E	0,50	0,22	0,24	0,26	30 (23 – 45)	
P6	E	0,50	0,22	0,24	0,26	34 (26 – 51)	
P7	E	0,50	0,22	0,24	0,26	32 (25 – 48)	
P8	E	0,50	0,24	0,25	0,28	30 (23 – 45)	
P11	E	0,50	0,22	0,24	0,26	31 (24 – 46)	
P12	E	0,40	0,12	0,13	0,15	20 (15 – 29)	
M1	E	0,50	0,22	0,24	0,26	30 (23 – 45)	
M2	E	0,50	0,22	0,24	0,26	30 (23 – 45)	
M3	E	0,40	0,17	0,18	0,20	24 (18 – 35)	
M4	E	0,30	0,13	0,14	0,16	18 (14 – 27)	
M5	E	0,30	0,13	0,14	0,16	15 (12 – 22)	
K1	E	0,50	0,22	0,24	0,26	30 (23 – 45)	
K2	E	0,50	0,20	0,22	0,24	26 (21 – 40)	
K3	E	0,50	0,20	0,22	0,24	22 (17 – 33)	
K4	E	0,50	0,20	0,22	0,24	21 (17 – 32)	
K5	E	0,50	0,18	0,19	0,22	13 (9,9 – 19)	
K6	E	0,50	0,20	0,22	0,24	19 (15 – 28)	
K7	E	0,50	0,18	0,19	0,22	17 (13 – 25)	
N1	E	0,50	0,22	0,24	0,26	30 (23 – 45)	
N2	E	0,50	0,22	0,24	0,26	19 (15 – 29)	
N3	E	0,50	0,22	0,24	0,26	13 (9,8 – 19)	
N11	E	0,50	0,22	0,24	0,26	17 (14 – 26)	
S1	E	0,50	0,24	0,26	0,28	43 (33 – 64)	
S2	E	0,50	0,24	0,26	0,28	34 (27 – 51)	
S3	E	0,50	0,22	0,24	0,26	30 (23 – 45)	
S11	E	0,50	0,22	0,24	0,26	39 (30 – 59)	
S12	E	0,50	0,22	0,24	0,26	30 (23 – 45)	
S13	E	0,42	0,19	0,20	0,24	23 (18 – 35)	
H5	M/A/D	0,50	0,22	0,24	0,26	30 (23 – 45)	
H8	M/A/D	0,42	0,16	0,17	0,18	32 (25 – 48)	
H11	M/A/D	0,50	0,22	0,24	0,26	39 (30 – 58)	
H12	M/A/D	0,36	0,070	0,080	0,085	12 (9,5 – 18)	
H21	M/A/D	0,42	0,16	0,17	0,18	32 (25 – 48)	
H31	M/A/D	0,42	0,12	0,12	0,14	25 (19 – 37)	
TS1	E	0,50	0,22	0,24	0,26	30 (23 – 45)	
TP1	E	0,50	0,22	0,24	0,26	30 (23 – 45)	
GR1	D	0,50	0,22	0,24	0,26	30 (23 – 45)	

For cutting data recalculations, see page 411-418.

SMG = Seco material group

Coolant = A=air D=dry E=emulsion M=mist spray

v_c = m/min

f_z = mm

a_p (mm)/DC (mm)= factor

All cutting data are target values

Cutting data – J36 Side milling

SMG		a _e /DC	a _p /DC	f _z												v _c
				2	3	4	5	6	8	10	12	14	16	18	20	
P1	E	0,20	1,0	0,013	0,019	0,026	0,032	0,038	0,050	0,065	0,075	0,085	0,095	0,10	0,11	200 (170 – 225)
P2	E	0,20	1,0	0,013	0,020	0,026	0,034	0,040	0,055	0,065	0,080	0,090	0,095	0,10	0,11	190 (165 – 220)
P3	E	0,20	1,0	0,012	0,019	0,024	0,032	0,038	0,050	0,060	0,075	0,085	0,090	0,10	0,11	170 (145 – 190)
P4	E	0,20	1,0	0,012	0,018	0,024	0,030	0,036	0,048	0,060	0,070	0,080	0,090	0,095	0,10	150 (125 – 170)
P5	E	0,20	1,0	0,012	0,018	0,024	0,030	0,036	0,048	0,060	0,070	0,080	0,090	0,095	0,10	140 (120 – 160)
P6	E	0,20	1,0	0,012	0,018	0,024	0,030	0,036	0,048	0,060	0,070	0,080	0,085	0,095	0,10	160 (135 – 180)
P7	E	0,20	1,0	0,012	0,018	0,024	0,030	0,036	0,048	0,060	0,070	0,080	0,085	0,095	0,10	150 (130 – 170)
P8	E	0,20	1,0	0,012	0,019	0,024	0,032	0,038	0,050	0,060	0,075	0,085	0,090	0,10	0,11	140 (120 – 160)
P11	E	0,20	1,0	0,012	0,018	0,024	0,030	0,036	0,048	0,060	0,070	0,080	0,085	0,095	0,10	145 (125 – 165)
P12	E	0,20	0,80	0,0065	0,010	0,013	0,017	0,020	0,026	0,034	0,040	0,044	0,048	0,055	0,055	95 (80 – 110)
M1	E	0,20	1,0	0,014	0,020	0,028	0,034	0,042	0,055	0,070	0,085	0,095	0,10	0,11	0,12	120 (95 – 140)
M2	E	0,20	1,0	0,013	0,019	0,026	0,032	0,038	0,050	0,065	0,075	0,085	0,095	0,10	0,11	95 (75 – 115)
M3	E	0,10	1,0	0,010	0,015	0,020	0,024	0,030	0,040	0,050	0,060	0,065	0,075	0,080	0,085	75 (55 – 95)
M4	E	0,10	0,70	0,0085	0,013	0,017	0,022	0,026	0,034	0,044	0,050	0,060	0,065	0,070	0,075	60 (43 – 75)
M5	E	0,10	0,70	0,0085	0,013	0,017	0,022	0,026	0,034	0,044	0,050	0,060	0,065	0,070	0,075	48 (35 – 60)
K1	E	0,20	1,0	0,012	0,018	0,024	0,030	0,036	0,048	0,060	0,070	0,080	0,090	0,095	0,10	140 (120 – 160)
K2	E	0,20	1,0	0,011	0,016	0,022	0,028	0,032	0,044	0,055	0,065	0,075	0,080	0,085	0,090	125 (105 – 140)
K3	E	0,20	1,0	0,011	0,016	0,022	0,028	0,032	0,044	0,055	0,065	0,075	0,080	0,085	0,090	105 (90 – 120)
K4	E	0,20	1,0	0,011	0,016	0,022	0,028	0,032	0,044	0,055	0,065	0,075	0,080	0,085	0,090	100 (85 – 115)
K5	E	0,20	1,0	0,0095	0,014	0,019	0,024	0,028	0,038	0,048	0,055	0,065	0,070	0,075	0,080	60 (55 – 70)
K6	E	0,20	1,0	0,011	0,016	0,022	0,028	0,032	0,044	0,055	0,065	0,075	0,080	0,085	0,090	90 (75 – 100)
K7	E	0,20	1,0	0,0095	0,014	0,019	0,024	0,028	0,038	0,048	0,055	0,065	0,070	0,075	0,080	80 (65 – 90)
N1	E	0,40	1,0	0,020	0,030	0,040	0,050	0,060	0,080	0,10	0,12	0,13	0,15	0,16	0,17	620 (510 – 720)
N2	E	0,40	1,0	0,020	0,030	0,040	0,050	0,060	0,080	0,10	0,12	0,13	0,15	0,16	0,17	395 (330 – 465)
S1	E	0,10	1,0	0,0060	0,0090	0,012	0,015	0,018	0,024	0,030	0,036	0,040	0,044	0,048	0,050	75 (60 – 85)
S2	E	0,10	1,0	0,0060	0,0090	0,012	0,015	0,018	0,024	0,030	0,036	0,040	0,044	0,048	0,050	60 (49 – 70)
S3	E	0,10	1,0	0,0040	0,0060	0,0080	0,010	0,012	0,016	0,020	0,024	0,026	0,030	0,032	0,034	40 (30 – 50)
S11	E	0,25	1,1	0,011	0,016	0,022	0,026	0,032	0,042	0,055	0,065	0,070	0,080	0,085	0,090	105 (90 – 115)
S12	E	0,25	1,1	0,011	0,016	0,022	0,026	0,032	0,042	0,055	0,065	0,070	0,080	0,085	0,090	80 (70 – 90)
S13	E	0,25	1,0	0,0095	0,014	0,019	0,024	0,028	0,038	0,046	0,055	0,060	0,070	0,075	0,080	65 (55 – 70)
TS1	A	0,40	1,0	0,020	0,030	0,040	0,050	0,060	0,080	0,10	0,12	0,13	0,15	0,16	0,17	500 (455 – 560)
TP1	A	0,40	1,0	0,020	0,030	0,040	0,050	0,060	0,080	0,10	0,12	0,13	0,15	0,16	0,17	500 (455 – 560)

For cutting data recalculations, see page 411-418.

SMG = Seco material group

Coolant = A=air D=dry E=emulsion M=mist spray

v_c = m/min

f_z = mm

a_p (mm)/DC (mm) = factor

a_e (mm)/DC (mm) = factor

All cutting data are target values

Cutting data – V31 Side milling finishing $a_p/DC=0,024$

SMG		a_p/DC	f_z									v_c
			6	8	10	12	16	20	25	28		
P1	E/M/A	0,24	0,024	0,032	0,040	0,048	0,065	0,080	0,095	0,10	290 (195 — 310)	
P2	E/M/A	0,24	0,024	0,034	0,042	0,050	0,065	0,080	0,095	0,10	280 (190 — 305)	
P3	E/M/A	0,24	0,024	0,032	0,040	0,046	0,060	0,075	0,090	0,095	240 (165 — 260)	
M1	E/M/A	0,24	0,024	0,034	0,042	0,050	0,065	0,080	0,095	0,10	255 (170 — 270)	
M2	E/M/A	0,24	0,022	0,030	0,038	0,046	0,060	0,075	0,085	0,095	205 (135 — 220)	
K1	E/M/A	0,24	0,022	0,030	0,038	0,046	0,060	0,075	0,085	0,095	205 (135 — 220)	
K2	E/M/A	0,24	0,020	0,028	0,034	0,040	0,055	0,065	0,080	0,085	175 (120 — 190)	
N1	E/M/A	0,24	0,022	0,030	0,038	0,046	0,060	0,075	0,085	0,095	315 (215 — 340)	
N2	E/M/A	0,24	0,022	0,030	0,038	0,046	0,060	0,075	0,085	0,095	205 (135 — 220)	
N3	E/M/A	0,24	0,022	0,030	0,038	0,046	0,060	0,075	0,085	0,095	135 (90 — 145)	
S1	E/M/A	0,24	0,024	0,032	0,040	0,048	0,065	0,080	0,095	0,10	205 (140 — 220)	
S2	E/M/A	0,24	0,024	0,032	0,040	0,048	0,065	0,080	0,095	0,10	205 (140 — 220)	
S3	E/M/A	0,24	0,022	0,030	0,038	0,046	0,060	0,075	0,085	0,095	205 (135 — 220)	
S11	E/M/A	0,24	0,022	0,030	0,038	0,046	0,060	0,075	0,085	0,095	265 (180 — 285)	
H3	M/A	—	—	—	—	—	—	—	—	—	—	
TS1	A/D	0,24	0,022	0,030	0,038	0,046	0,060	0,075	0,085	0,095	205 (135 — 220)	
TP1	A/D	0,24	0,022	0,030	0,038	0,046	0,060	0,075	0,085	0,095	205 (135 — 220)	
GR1	A/D	0,24	0,022	0,030	0,038	0,046	0,060	0,075	0,085	0,095	205 (135 — 220)	

For cutting data recalculations, see page 411-418.

SMG = Seco material group

Coolant = A=air D=dry E=emulsion M=mist spray

v_c = m/min

f_z = mm

a_p (mm)/DC (mm)= factor

All cutting data are target values



JME542 – Miniature – Universal – Square – 2 Flutes – DMM 4 – Cylindrical – Sharp or corner radius



Tolerances:
 Run-out= <0,007 mm
 DMM= h5
 DC= Ø0,2-Ø0,4= 0,-0,01 mm
 DC= Ø0,5-Ø3,0= 0,-0,013 mm
 RE= ±0,005 mm

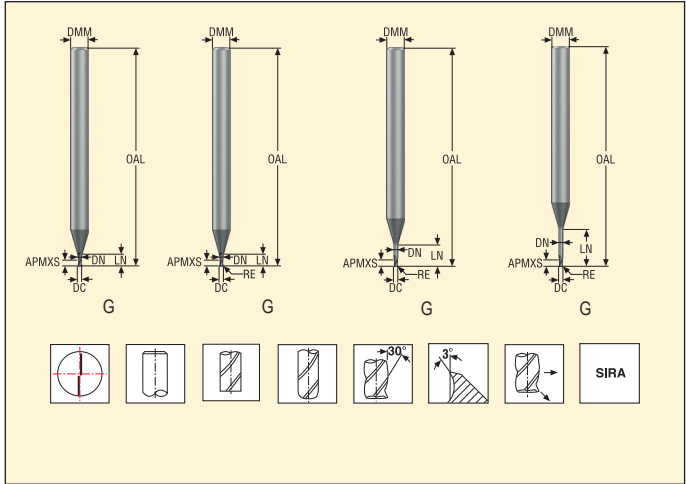

Ordering and Product No.	Designation	Length index	Tool shape	Dimensions in mm								P/CEDC	CA	Max. cut depth rel. to a_{η} (a_{η} , ref)*						
				DC	DMM	APMXS	OAL	LN	DN	RE	WDX0			WDX05	WDX1	WDX15	WDX2	WDX3		
03171095	JME542002G1S.0Z2-SIRA	1	G	0,2	4	0,3	45	0,4	0,18	-	2	14,41	0,56	0,63	0,69	0,75	0,81	0,91		
03171096	JME542003G1S.0Z2-SIRA	1	G	0,3	4	0,5	45	0,6	0,28	-	2	14,0	0,76	0,85	0,92	0,99	1,06	1,17		
03171128	JME542004G1S.0Z2-SIRA	1	G	0,4	4	0,6	45	0,8	0,37	-	2	13,5	1,12	1,19	1,26	1,32	1,38	1,49		
03171097	JME542005G1R005.0Z2-SIRA	1	G	0,5	4	0,8	45	1,0	0,46	0,05	2	13,17	1,32	1,4	1,47	1,54	1,61	1,73		
03171098	JME542006G1R005.0Z2-SIRA	1	G	0,6	4	0,9	45	1,2	0,56	0,05	2	12,76	1,52	1,61	1,69	1,77	1,84	1,97		
03171129	JME542008G1R005.0Z2-SIRA	1	G	0,8	4	1,2	45	1,6	0,76	0,05	2	11,96	1,92	2,03	2,13	2,22	2,3	2,46		
03171099	JME542010G1R010.0Z2-SIRA	1	G	1,0	4	1,5	50	2,0	0,95	0,1	2	11,22	2,32	2,45	2,56	2,65	2,74	2,94		
03171100	JME542012G1R010.0Z2-SIRA	1	G	1,2	4	1,8	50	2,4	1,15	0,1	2	10,43	2,77	2,87	2,99	3,1	3,2	3,43		
03171130	JME542015G1R015.0Z2-SIRA	1	G	1,5	4	2,3	50	3,0	1,45	0,15	2	9,2	3,47	3,61	3,73	3,85	3,98	4,26		
03171102	JME542005G3R005.0Z2-SIRA	3	G	0,5	4	0,8	45	2,5	0,46	0,05	2	11,03	2,82	2,98	3,1	3,21	3,32	3,56		
03171103	JME542006G3R005.0Z2-SIRA	3	G	0,6	4	0,9	45	3,0	0,56	0,05	2	10,36	3,32	3,5	3,64	3,76	3,89	4,18		
03171131	JME542008G3R005.0Z2-SIRA	3	G	0,8	4	1,2	45	4,0	0,76	0,05	2	9,14	4,32	4,54	4,7	4,86	5,03	5,4		
03171104	JME542010G3R010.0Z2-SIRA	3	G	1,0	4	1,5	50	5,0	0,95	0,1	2	8,09	5,32	5,58	5,77	5,96	6,16	6,61		
03171105	JME542012G3R010.0Z2-SIRA	3	G	1,2	4	1,8	50	6,0	1,15	0,1	2	7,13	6,32	6,62	6,83	7,06	7,3	7,84		
03171132	JME542015G3R015.0Z2-SIRA	3	G	1,5	4	2,3	50	7,5	1,45	0,15	2	5,89	7,82	8,16	8,43	8,7	9,0	9,66		
03171106	JME542020G3R015.0Z2-SIRA	3	G	2,0	4	3,0	50	10,0	1,94	0,15	2	4,14	10,47	10,83	11,18	11,55	11,95	12,83		
03171108	JME542025G3R015.0Z2-SIRA	3	G	2,5	4	3,8	50	12,5	2,4	0,15	2	2,79	12,97	13,41	13,84	14,3	14,79	∞		
03171134	JME542030G3R015.0Z2-SIRA	3	G	3,0	4	4,5	60	15,0	2,85	0,15	2	1,67	15,68	16,17	16,69	17,24	∞	∞		
03171109	JME542005G4R005.0Z2-SIRA	4	G	0,5	4	0,8	45	4,0	0,46	0,05	2	9,49	4,32	4,54	4,7	4,86	5,03	5,4		
03171110	JME542006G4R005.0Z2-SIRA	4	G	0,6	4	0,9	45	5,0	0,56	0,05	2	8,56	5,32	5,58	5,77	5,96	6,17	6,62		
03171135	JME542008G4R005.0Z2-SIRA	4	G	0,8	4	1,2	45	7,0	0,76	0,05	2	7,05	7,32	7,65	7,9	8,16	8,44	9,07		
03171111	JME542010G4R010.0Z2-SIRA	4	G	1,0	4	1,5	50	8,5	0,95	0,1	2	6,1	8,82	9,2	9,49	9,81	10,15	10,9		
03171112	JME542012G4R010.0Z2-SIRA	4	G	1,2	4	1,8	50	10,0	1,15	0,1	2	5,27	10,32	10,75	11,09	11,46	11,85	12,73		
03171136	JME542015G4R015.0Z2-SIRA	4	G	1,5	4	2,3	50	12,0	1,45	0,15	2	4,29	12,47	12,9	13,31	13,75	14,22	15,27		
03171113	JME542020G4R015.0Z2-SIRA	4	G	2,0	4	3,0	60	16,0	1,94	0,15	2	2,9	16,47	17,02	17,57	18,15	18,78	∞		
03171114	JME542025G4R015.0Z2-SIRA	4	G	2,5	4	3,8	60	20,0	2,4	0,15	2	1,88	20,47	21,15	21,83	22,55	∞	∞		
03171137	JME542030G4R015.0Z2-SIRA	4	G	3,0	4	4,5	70	24,0	2,85	0,15	2	1,1	24,68	25,45	26,27	∞	∞	∞		
03171115	JME542015G5R015.0Z2-SIRA	5	G	1,5	4	2,3	60	15,0	1,45	0,15	2	3,64	15,47	15,99	16,5	17,05	17,64	18,95		
03171116	JME542020G5R015.0Z2-SIRA	5	G	2,0	4	3,0	60	20,0	1,94	0,15	2	2,41	20,47	21,15	21,83	22,55	23,33	∞		
03171138	JME542025G5R015.0Z2-SIRA	5	G	2,5	4	3,8	70	25,0	2,4	0,15	2	1,54	25,47	26,3	27,15	28,06	∞	∞		
03171117	JME542030G5R015.0Z2-SIRA	5	G	3,0	4	4,5	70	30,0	2,85	0,15	2	0,9	30,68	31,64	∞	∞	∞	∞		
03171118	JME542015G6R015.0Z2-SIRA	6	G	1,5	4	2,3	70	22,5	1,45	0,15	2	2,64	22,97	23,73	24,49	25,29	26,18	∞		
03171139	JME542020G6R015.0Z2-SIRA	6	G	2,0	4	3,0	70	30,0	1,94	0,15	2	1,7	30,47	31,46	32,48	33,56	∞	∞		
03171119	JME542025G6R015.0Z2-SIRA	6	G	2,5	4	3,8	80	37,5	2,4	0,15	2	1,07	37,97	39,2	40,46	∞	∞	∞		
03171120	JME542030G6R015.0Z2-SIRA	6	G	3,0	4	4,5	90	45,0	2,85	0,15	2	0,61	45,68	47,11	∞	∞	∞	∞		

Stock standard. Subject to change refer to current price- and stock-list

Cutting data – JME542/JME562 Side milling roughing

SMG		a _e /DC	a _p /DC	f _z												v _c
				0,2	0,3	0,4	0,5	0,6	0,8	1,0	1,2	1,8	2,0	2,5	3,0	
P1	M/E/A	0,050	0,60	0,0060	0,0090	0,012	0,015	0,018	0,024	0,030	0,036	0,055	0,060	0,075	0,090	405 (360 – 450)
P2	M/E/A	0,050	0,60	0,0060	0,0090	0,012	0,015	0,018	0,024	0,030	0,036	0,055	0,060	0,075	0,090	395 (355 – 440)
P3	M/E/A	0,050	0,60	0,0060	0,0090	0,012	0,015	0,018	0,024	0,030	0,036	0,055	0,060	0,075	0,090	340 (300 – 380)
P4	M/E/A	0,050	0,60	0,0060	0,0090	0,012	0,015	0,018	0,024	0,030	0,036	0,055	0,060	0,075	0,090	300 (270 – 335)
P5	M/E/A	0,050	0,60	0,0060	0,0090	0,012	0,015	0,018	0,024	0,030	0,036	0,055	0,060	0,075	0,090	285 (255 – 320)
P6	M/E/A	0,050	0,60	0,0060	0,0090	0,012	0,015	0,018	0,024	0,030	0,036	0,055	0,060	0,075	0,090	320 (290 – 360)
P7	M/E/A	0,050	0,60	0,0060	0,0090	0,012	0,015	0,018	0,024	0,030	0,036	0,055	0,060	0,075	0,090	305 (270 – 340)
P8	M/E/A	0,050	0,60	0,0060	0,0090	0,012	0,015	0,018	0,024	0,030	0,036	0,055	0,060	0,075	0,090	285 (255 – 320)
P11	M/E/A	0,050	0,60	0,0060	0,0090	0,012	0,015	0,018	0,024	0,030	0,036	0,055	0,060	0,075	0,090	295 (265 – 330)
P12	M/E/A	0,050	0,60	0,0048	0,0075	0,010	0,012	0,015	0,020	0,024	0,030	0,042	0,044	0,050	0,055	175 (160 – 195)
M1	E/M/A	0,050	0,60	0,0060	0,0090	0,012	0,015	0,018	0,024	0,030	0,036	0,055	0,060	0,075	0,090	215 (180 – 260)
M2	E/M/A	0,050	0,60	0,0060	0,0090	0,012	0,015	0,018	0,024	0,030	0,036	0,055	0,060	0,075	0,090	175 (145 – 205)
M3	E/M/A	0,050	0,60	0,0060	0,0090	0,012	0,015	0,018	0,024	0,030	0,036	0,055	0,060	0,075	0,090	175 (145 – 205)
M4	E/M/A	0,050	0,60	0,0060	0,0090	0,012	0,015	0,018	0,024	0,030	0,036	0,055	0,060	0,075	0,085	130 (110 – 155)
M5	E/M/A	0,050	0,60	0,0060	0,0090	0,012	0,015	0,018	0,024	0,030	0,036	0,055	0,060	0,075	0,085	110 (90 – 130)
N1	E/M/A	0,10	0,75	0,0060	0,0090	0,012	0,015	0,018	0,024	0,030	0,036	0,055	0,060	0,075	0,085	550 (485 – 620)
N2	E/M/A	0,10	0,75	0,0060	0,0090	0,012	0,015	0,018	0,024	0,030	0,036	0,050	0,055	0,060	0,065	550 (485 – 620)
N3	E/M/A	0,10	0,75	0,0060	0,0090	0,012	0,015	0,018	0,024	0,030	0,036	0,050	0,055	0,060	0,065	370 (325 – 415)
N11	E/M/A	0,10	0,75	0,0060	0,0090	0,012	0,015	0,018	0,024	0,030	0,036	0,055	0,060	0,075	0,085	500 (430 – 575)
S11	E/M/A	0,050	0,60	0,0060	0,0090	0,012	0,015	0,018	0,024	0,030	0,036	0,055	0,060	0,075	0,090	290 (250 – 330)
S12	E/M/A	0,050	0,60	0,0060	0,0090	0,012	0,015	0,018	0,024	0,030	0,036	0,055	0,060	0,075	0,090	225 (190 – 255)
S13	E/M/A	0,050	0,60	0,0060	0,0090	0,012	0,015	0,018	0,024	0,030	0,036	0,055	0,060	0,075	0,085	175 (150 – 200)
H3	M/A	0,050	0,30	0,0060	0,0090	0,012	0,015	0,018	0,024	0,030	0,036	0,050	0,055	0,060	0,065	120 (90 – 120)
H5	M/A	0,050	0,44	0,0060	0,0090	0,012	0,015	0,018	0,024	0,030	0,036	0,055	0,060	0,075	0,090	250 (220 – 280)
H7	M/A	0,050	0,30	0,0060	0,0090	0,012	0,015	0,018	0,024	0,030	0,036	0,050	0,055	0,060	0,065	120 (90 – 150)
H8	M/A	0,050	0,44	0,0055	0,0080	0,011	0,014	0,016	0,022	0,028	0,032	0,050	0,055	0,060	0,065	250 (220 – 280)
H11	M/A	0,050	0,44	0,0060	0,0090	0,012	0,015	0,018	0,024	0,030	0,036	0,055	0,060	0,075	0,090	320 (280 – 330)
H12	M/A	0,050	0,44	0,0055	0,0080	0,011	0,014	0,016	0,022	0,028	0,032	0,050	0,055	0,060	0,065	295 (260 – 330)
H21	M/A	0,050	0,44	0,0055	0,0080	0,011	0,014	0,016	0,022	0,028	0,032	0,050	0,055	0,060	0,065	250 (220 – 280)
H31	M/A	0,050	0,44	0,0046	0,0070	0,0095	0,012	0,014	0,019	0,024	0,028	0,036	0,040	0,044	0,048	190 (170 – 215)
GR1	A	0,50	0,50	0,0030	0,0044	0,0060	0,0075	0,0090	0,012	0,015	0,018	0,024	0,025	0,028	0,032	405 (350 – 460)

Table based on LV1, please recalc based on length version chosen. See page(s) 411-418

SMG = Seco material group

Coolant = A=air D=dry E=emulsion M=mist spray

v_c = m/min

f_z = mm

a_p (mm)/DC (mm)= factor

a_e (mm)/DC (mm)= factor

All cutting data are target values

Cutting data – JME542/JME562 Slot milling



SMG		a_p /DC	f_z													
			0,2	0,3	0,4	0,5	0,6	0,8	1,0	1,2	1,8	2,0	2,5	3,0	v_c	
P1	M/E/A	0,32	0,0026	0,0040	0,0050	0,0065	0,0080	0,010	0,013	0,016	0,024	0,026	0,032	0,040	255 (230 – 285)	
P2	M/E/A	0,32	0,0026	0,0040	0,0050	0,0065	0,0080	0,010	0,013	0,016	0,024	0,026	0,032	0,040	250 (220 – 275)	
P3	M/E/A	0,32	0,0026	0,0040	0,0050	0,0065	0,0080	0,010	0,013	0,016	0,024	0,026	0,032	0,040	215 (190 – 235)	
P4	M/E/A	0,32	0,0026	0,0040	0,0050	0,0065	0,0080	0,010	0,013	0,016	0,024	0,026	0,032	0,040	190 (170 – 210)	
P5	M/E/A	0,32	0,0026	0,0040	0,0050	0,0065	0,0080	0,010	0,013	0,016	0,024	0,026	0,032	0,040	180 (160 – 200)	
P6	M/E/A	0,32	0,0026	0,0040	0,0050	0,0065	0,0080	0,010	0,013	0,016	0,024	0,026	0,032	0,040	200 (180 – 225)	
P7	M/E/A	0,32	0,0026	0,0040	0,0050	0,0065	0,0080	0,010	0,013	0,016	0,024	0,026	0,032	0,040	190 (170 – 210)	
P8	M/E/A	0,32	0,0026	0,0040	0,0050	0,0065	0,0080	0,010	0,013	0,016	0,024	0,026	0,032	0,040	180 (160 – 200)	
P11	M/E/A	0,32	0,0026	0,0040	0,0050	0,0065	0,0080	0,010	0,013	0,016	0,024	0,026	0,032	0,040	185 (165 – 205)	
P12	M/E/A	0,32	0,0022	0,0032	0,0042	0,0055	0,0065	0,0085	0,011	0,013	0,018	0,019	0,022	0,024	110 (100 – 120)	
M1	E/M/A	0,32	0,0026	0,0040	0,0050	0,0065	0,0080	0,010	0,013	0,016	0,024	0,026	0,032	0,040	135 (110 – 160)	
M2	E/M/A	0,32	0,0026	0,0040	0,0050	0,0065	0,0080	0,010	0,013	0,016	0,024	0,026	0,032	0,040	110 (90 – 130)	
M3	E/M/A	0,32	0,0026	0,0040	0,0050	0,0065	0,0080	0,010	0,013	0,016	0,024	0,026	0,032	0,040	110 (90 – 130)	
M4	E/M/A	0,32	0,0026	0,0040	0,0050	0,0065	0,0080	0,010	0,013	0,016	0,024	0,026	0,032	0,036	80 (70 – 100)	
M5	E/M/A	0,32	0,0026	0,0040	0,0050	0,0065	0,0080	0,010	0,013	0,016	0,024	0,026	0,032	0,036	70 (55 – 80)	
N1	E/M/A	0,24	0,0026	0,0040	0,0050	0,0065	0,0080	0,010	0,013	0,016	0,024	0,026	0,032	0,040	400 (350 – 450)	
N2	E/M/A	0,24	0,0026	0,0040	0,0050	0,0065	0,0080	0,010	0,013	0,016	0,024	0,026	0,032	0,040	400 (350 – 450)	
N3	E/M/A	0,24	0,0026	0,0040	0,0050	0,0065	0,0080	0,010	0,013	0,016	0,024	0,026	0,032	0,040	265 (235 – 300)	
N11	E/M/A	0,24	0,0040	0,0060	0,0080	0,010	0,012	0,016	0,020	0,024	0,036	0,040	0,048	0,055	350 (300 – 400)	
S11	E/M/A	0,36	0,0026	0,0040	0,0050	0,0065	0,0080	0,010	0,013	0,016	0,024	0,026	0,032	0,040	180 (155 – 205)	
S12	E/M/A	0,36	0,0026	0,0040	0,0050	0,0065	0,0080	0,010	0,013	0,016	0,024	0,026	0,032	0,040	140 (120 – 130)	
S13	E/M/A	0,36	0,0026	0,0040	0,0050	0,0065	0,0080	0,010	0,013	0,016	0,024	0,026	0,032	0,036	110 (90 – 125)	
H3	M/A	0,095	0,0024	0,0036	0,0048	0,0060	0,0070	0,0095	0,012	0,014	0,022	0,024	0,030	0,036	80 (60 – 100)	
H5	M/A	0,20	0,0026	0,0040	0,0050	0,0065	0,0080	0,010	0,013	0,016	0,024	0,026	0,032	0,040	160 (140 – 180)	
H7	M/A	0,095	0,0024	0,0036	0,0048	0,0060	0,0070	0,0095	0,012	0,014	0,022	0,024	0,030	0,036	80 (60 – 100)	
H8	M/A	0,20	0,0024	0,0036	0,0048	0,0060	0,0070	0,0095	0,012	0,014	0,022	0,024	0,026	0,030	160 (140 – 180)	
H11	M/A	0,20	0,0026	0,0040	0,0050	0,0065	0,0080	0,010	0,013	0,016	0,024	0,026	0,032	0,040	205 (180 – 230)	
H12	M/A	0,20	0,0024	0,0036	0,0048	0,0060	0,0070	0,0095	0,012	0,014	0,022	0,024	0,026	0,030	190 (165 – 210)	
H21	M/A	0,20	0,0024	0,0036	0,0048	0,0060	0,0070	0,0095	0,012	0,014	0,022	0,024	0,026	0,030	160 (140 – 180)	
H31	M/A	0,20	0,0020	0,0030	0,0042	0,0050	0,0060	0,0080	0,010	0,012	0,017	0,018	0,020	0,022	125 (110 – 140)	
GR1	A	0,50	0,0020	0,0030	0,0040	0,0050	0,0060	0,0080	0,010	0,012	0,018	0,020	0,025	0,030	350 (300 – 400)	

Table based on LV1, please recalc based on length version chosen. See page(s) 411-418

SMG = Seco material group

Coolant = A=air D=dry E=emulsion M=mist spray

v_c = m/min

f_z = mm

a_p (mm)/DC (mm)= factor

a_s (mm)/DC (mm)= factor

All cutting data are target values

Cutting data – JME564 Side milling roughing

SMG		a _e /DC	a _p /DC	f _z										v _c
				0,5	0,6	0,8	1,0	1,2	1,5	2,0	2,5	3		
P1	M/E/A	0,050	0,50	0,010	0,012	0,016	0,020	0,024	0,030	0,040	0,050	0,060	395 (352 – 439)	
P2	M/E/A	0,050	0,50	0,010	0,012	0,016	0,020	0,024	0,030	0,040	0,050	0,060	385 (342 – 427)	
P3	M/E/A	0,050	0,50	0,010	0,012	0,016	0,020	0,024	0,030	0,040	0,050	0,060	330 (295 – 367)	
P4	M/E/A	0,050	0,50	0,010	0,012	0,016	0,020	0,024	0,030	0,040	0,050	0,060	290 (260 – 323)	
P5	M/E/A	0,050	0,50	0,010	0,012	0,016	0,020	0,024	0,030	0,040	0,050	0,060	280 (248 – 309)	
P6	M/E/A	0,050	0,50	0,010	0,012	0,016	0,020	0,024	0,030	0,040	0,050	0,060	310 (278 – 347)	
P7	M/E/A	0,050	0,50	0,010	0,012	0,016	0,020	0,024	0,030	0,040	0,050	0,060	295 (263 – 327)	
P8	M/E/A	0,050	0,50	0,010	0,012	0,016	0,020	0,024	0,030	0,040	0,050	0,060	280 (248 – 309)	
P11	M/E/A	0,050	0,50	0,010	0,012	0,016	0,020	0,024	0,030	0,040	0,050	0,060	285 (255 – 318)	
P12	M/E/A	0,050	0,50	0,0080	0,010	0,013	0,016	0,020	0,024	0,032	0,040	0,048	170 (151 – 188)	
M1	E/M/A	0,024	0,50	0,010	0,012	0,016	0,020	0,024	0,030	0,040	0,050	0,060	235 (195 – 280)	
M2	E/M/A	0,024	0,50	0,010	0,012	0,016	0,020	0,024	0,030	0,040	0,050	0,060	190 (157 – 226)	
M3	E/M/A	0,024	0,50	0,010	0,012	0,016	0,020	0,024	0,030	0,040	0,050	0,060	190 (157 – 226)	
M4	E/M/A	0,024	0,50	0,010	0,012	0,016	0,020	0,024	0,030	0,040	0,050	0,060	145 (118 – 169)	
M5	E/M/A	0,024	0,50	0,010	0,012	0,016	0,020	0,024	0,030	0,040	0,050	0,060	120 (98,1 – 141)	
N1	E/M/A	0,10	0,90	0,010	0,012	0,016	0,020	0,024	0,030	0,040	0,050	0,060	550 (481 – 618)	
N2	E/M/A	0,10	0,90	0,010	0,012	0,016	0,020	0,024	0,030	0,040	0,050	0,060	550 (481 – 618)	
N3	E/M/A	0,10	0,90	0,010	0,012	0,016	0,020	0,024	0,030	0,040	0,050	0,060	365 (321 – 412)	
N11	E/M/A	0,10	0,90	0,012	0,015	0,020	0,025	0,030	0,038	0,050	0,060	0,075	490 (422 – 561)	
S11	E/M/A	0,050	0,60	0,010	0,012	0,016	0,020	0,024	0,030	0,040	0,050	0,060	285 (246 – 327)	
S12	E/M/A	0,050	0,60	0,010	0,012	0,016	0,020	0,024	0,030	0,040	0,050	0,060	220 (190 – 252)	
S13	E/M/A	0,050	0,60	0,010	0,012	0,016	0,020	0,024	0,030	0,040	0,050	0,060	170 (147 – 195)	
H3	M/A	0,050	0,060	0,0090	0,011	0,014	0,018	0,022	0,025	0,030	0,034	0,038	125 (94,5 – 157)	
H5	M/A	0,050	0,28	0,010	0,012	0,016	0,020	0,024	0,030	0,040	0,050	0,060	240 (209 – 268)	
H7	M/A	0,050	0,060	0,0090	0,011	0,014	0,018	0,022	0,025	0,030	0,034	0,038	125 (94,5 – 157)	
H8	M/A	0,050	0,28	0,0090	0,011	0,015	0,018	0,022	0,028	0,036	0,046	0,050	240 (210 – 268)	
H11	M/A	0,050	0,28	0,010	0,012	0,016	0,020	0,024	0,030	0,040	0,050	0,060	305 (266 – 341)	
H12	M/A	0,050	0,28	0,0090	0,011	0,015	0,018	0,022	0,028	0,036	0,046	0,050	280 (244 – 312)	
H21	M/A	0,050	0,28	0,0090	0,011	0,015	0,018	0,022	0,028	0,036	0,046	0,050	240 (210 – 268)	
H31	M/A	0,050	0,28	0,0080	0,0095	0,013	0,016	0,019	0,024	0,032	0,034	0,038	180 (159 – 203)	
GR1	A	0,50	0,65	0,0075	0,0090	0,012	0,015	0,018	0,020	0,025	0,028	0,032	390 (335 – 446)	

Table based on LV1, please recalc based on length version chosen. See page(s) 411-418

SMG = Seco material group

Coolant = A=air D=dry E=emulsion M=mist spray

v_c = m/min

f_z = mm

a_p (mm)/DC (mm)= factor

a_e (mm)/DC (mm)= factor

All cutting data are target values

Cutting data – JME564 Slot milling

SMG		a _p /DC	f _z										v _c
			0,5	0,6	0,8	1,0	1,2	1,5	2,0	2,5	3		
P1	M/E/A	0,038	0,0065	0,0080	0,010	0,013	0,016	0,020	0,026	0,032	0,040	250 (225 – 280)	
P2	M/E/A	0,038	0,0065	0,0080	0,010	0,013	0,016	0,020	0,026	0,032	0,040	245 (215 – 270)	
P3	M/E/A	0,038	0,0065	0,0080	0,010	0,013	0,016	0,020	0,026	0,032	0,040	210 (185 – 230)	
P4	M/E/A	0,038	0,0065	0,0080	0,010	0,013	0,016	0,020	0,026	0,032	0,040	185 (165 – 205)	
P5	M/E/A	0,038	0,0065	0,0080	0,010	0,013	0,016	0,020	0,026	0,032	0,040	175 (157 – 200)	
P6	M/E/A	0,038	0,0065	0,0080	0,010	0,013	0,016	0,020	0,026	0,032	0,040	200 (175 – 220)	
P7	M/E/A	0,038	0,0065	0,0080	0,010	0,013	0,016	0,020	0,026	0,032	0,040	185 (165 – 205)	
P8	M/E/A	0,038	0,0065	0,0080	0,010	0,013	0,016	0,020	0,026	0,032	0,040	175 (155 – 195)	
P11	M/E/A	0,038	0,0065	0,0080	0,010	0,013	0,016	0,020	0,026	0,032	0,040	180 (160 – 200)	
P12	M/E/A	0,038	0,0055	0,0065	0,0085	0,011	0,013	0,016	0,019	0,022	0,024	105 (95 – 120)	
M1	E/M/A	0,038	0,0065	0,0080	0,010	0,013	0,016	0,020	0,026	0,032	0,040	135 (110 – 160)	
M2	E/M/A	0,038	0,0065	0,0080	0,010	0,013	0,016	0,020	0,026	0,032	0,040	110 (90 – 130)	
M3	E/M/A	0,038	0,0065	0,0080	0,010	0,013	0,016	0,020	0,026	0,032	0,040	110 (90 – 130)	
M4	E/M/A	0,038	0,0065	0,0080	0,010	0,013	0,016	0,020	0,026	0,032	0,036	80 (65 – 95)	
M5	E/M/A	0,038	0,0065	0,0080	0,010	0,013	0,016	0,020	0,026	0,032	0,036	65 (55 – 80)	
N1	E/M/A	0,15	0,0065	0,0080	0,010	0,013	0,016	0,020	0,026	0,032	0,040	390 (345 – 440)	
N2	E/M/A	0,15	0,0065	0,0080	0,010	0,013	0,016	0,020	0,026	0,032	0,040	390 (345 – 440)	
N3	E/M/A	0,15	0,0065	0,0080	0,010	0,013	0,016	0,020	0,026	0,032	0,040	260 (230 – 295)	
N11	E/M/A	0,15	0,010	0,012	0,016	0,020	0,024	0,030	0,040	0,048	0,050	345 (295 – 390)	
S11	E/M/A	0,11	0,0065	0,0080	0,010	0,013	0,016	0,020	0,026	0,032	0,040	180 (155 – 205)	
S12	E/M/A	0,11	0,0065	0,0080	0,010	0,013	0,016	0,020	0,026	0,032	0,040	135 (120 – 155)	
S13	E/M/A	0,11	0,0065	0,0080	0,010	0,013	0,016	0,020	0,026	0,032	0,036	105 (90 – 120)	
H3	M/A	0,0060	0,0060	0,0070	0,0095	0,012	0,014	0,018	0,024	0,030	0,036	80 (60 – 100)	
H5	M/A	0,020	0,0065	0,0080	0,010	0,013	0,016	0,020	0,026	0,032	0,040	160 (140 – 175)	
H7	M/A	0,0060	0,0060	0,0070	0,0095	0,012	0,014	0,018	0,024	0,030	0,036	80 (60 – 100)	
H8	M/A	0,020	0,0060	0,0070	0,0095	0,012	0,014	0,018	0,024	0,026	0,030	160 (140 – 175)	
H11	M/A	0,020	0,0065	0,0080	0,010	0,013	0,016	0,020	0,026	0,032	0,040	200 (175 – 225)	
H12	M/A	0,020	0,0060	0,0070	0,0095	0,012	0,014	0,018	0,024	0,026	0,030	185 (160 – 205)	
H21	M/A	0,020	0,0060	0,0070	0,0095	0,012	0,014	0,018	0,024	0,026	0,030	160 (140 – 175)	
H31	M/A	0,020	0,0050	0,0060	0,0080	0,010	0,012	0,015	0,018	0,020	0,022	120 (105 – 135)	
GR1	A	0,11	0,0050	0,0060	0,0080	0,010	0,012	0,015	0,020	0,025	0,030	345 (295 – 390)	

Table based on LV1, please recalc based on length version chosen. See page(s) 411-418

SMG = Seco material group

Coolant = A=air D=dry E=emulsion M=mist spray

v_c = m/min

f_z = mm

a_p (mm)/DC (mm)= factor

a_e (mm)/DC (mm)= factor

All cutting data are target values

Cutting data – JME542/JME562 Side milling roughing

SMG		a _g /DC	a _p /DC	f _z												v _c	
				0,2	0,3	0,4	0,5	0,6	0,8	1,0	1,2	1,8	2,0	2,5	3,0		
P1	M/E/A	0,050	0,60	0,0060	0,0090	0,012	0,015	0,018	0,024	0,030	0,036	0,055	0,060	0,075	0,090	405 (360 — 450)	
P2	M/E/A	0,050	0,60	0,0060	0,0090	0,012	0,015	0,018	0,024	0,030	0,036	0,055	0,060	0,075	0,090	395 (355 — 440)	
P3	M/E/A	0,050	0,60	0,0060	0,0090	0,012	0,015	0,018	0,024	0,030	0,036	0,055	0,060	0,075	0,090	340 (300 — 380)	
P4	M/E/A	0,050	0,60	0,0060	0,0090	0,012	0,015	0,018	0,024	0,030	0,036	0,055	0,060	0,075	0,090	300 (270 — 335)	
P5	M/E/A	0,050	0,60	0,0060	0,0090	0,012	0,015	0,018	0,024	0,030	0,036	0,055	0,060	0,075	0,090	285 (255 — 320)	
P6	M/E/A	0,050	0,60	0,0060	0,0090	0,012	0,015	0,018	0,024	0,030	0,036	0,055	0,060	0,075	0,090	320 (290 — 360)	
P7	M/E/A	0,050	0,60	0,0060	0,0090	0,012	0,015	0,018	0,024	0,030	0,036	0,055	0,060	0,075	0,090	305 (270 — 340)	
P8	M/E/A	0,050	0,60	0,0060	0,0090	0,012	0,015	0,018	0,024	0,030	0,036	0,055	0,060	0,075	0,090	285 (255 — 320)	
P11	M/E/A	0,050	0,60	0,0060	0,0090	0,012	0,015	0,018	0,024	0,030	0,036	0,055	0,060	0,075	0,090	295 (265 — 330)	
P12	M/E/A	0,050	0,60	0,0048	0,0075	0,010	0,012	0,015	0,020	0,024	0,030	0,042	0,044	0,050	0,055	175 (160 — 195)	
M1	E/M/A	0,050	0,60	0,0060	0,0090	0,012	0,015	0,018	0,024	0,030	0,036	0,055	0,060	0,075	0,090	215 (180 — 260)	
M2	E/M/A	0,050	0,60	0,0060	0,0090	0,012	0,015	0,018	0,024	0,030	0,036	0,055	0,060	0,075	0,090	175 (145 — 205)	
M3	E/M/A	0,050	0,60	0,0060	0,0090	0,012	0,015	0,018	0,024	0,030	0,036	0,055	0,060	0,075	0,090	175 (145 — 205)	
M4	E/M/A	0,050	0,60	0,0060	0,0090	0,012	0,015	0,018	0,024	0,030	0,036	0,055	0,060	0,075	0,085	130 (110 — 155)	
M5	E/M/A	0,050	0,60	0,0060	0,0090	0,012	0,015	0,018	0,024	0,030	0,036	0,055	0,060	0,075	0,085	110 (90 — 130)	
N1	E/M/A	0,10	0,75	0,0060	0,0090	0,012	0,015	0,018	0,024	0,030	0,036	0,055	0,060	0,075	0,085	550 (485 — 620)	
N2	E/M/A	0,10	0,75	0,0060	0,0090	0,012	0,015	0,018	0,024	0,030	0,036	0,050	0,055	0,060	0,065	550 (485 — 620)	
N3	E/M/A	0,10	0,75	0,0060	0,0090	0,012	0,015	0,018	0,024	0,030	0,036	0,050	0,055	0,060	0,065	370 (325 — 415)	
N11	E/M/A	0,10	0,75	0,0060	0,0090	0,012	0,015	0,018	0,024	0,030	0,036	0,055	0,060	0,075	0,085	500 (430 — 575)	
S11	E/M/A	0,050	0,60	0,0060	0,0090	0,012	0,015	0,018	0,024	0,030	0,036	0,055	0,060	0,075	0,090	290 (250 — 330)	
S12	E/M/A	0,050	0,60	0,0060	0,0090	0,012	0,015	0,018	0,024	0,030	0,036	0,055	0,060	0,075	0,090	225 (190 — 255)	
S13	E/M/A	0,050	0,60	0,0060	0,0090	0,012	0,015	0,018	0,024	0,030	0,036	0,055	0,060	0,075	0,085	175 (150 — 200)	
H3	M/A	0,050	0,30	0,0060	0,0090	0,012	0,015	0,018	0,024	0,030	0,036	0,050	0,055	0,060	0,065	120 (90 — 120)	
H5	M/A	0,050	0,44	0,0060	0,0090	0,012	0,015	0,018	0,024	0,030	0,036	0,055	0,060	0,075	0,090	250 (220 — 280)	
H7	M/A	0,050	0,30	0,0060	0,0090	0,012	0,015	0,018	0,024	0,030	0,036	0,050	0,055	0,060	0,065	120 (90 — 150)	
H8	M/A	0,050	0,44	0,0055	0,0080	0,011	0,014	0,016	0,022	0,028	0,032	0,050	0,055	0,060	0,065	250 (220 — 280)	
H11	M/A	0,050	0,44	0,0060	0,0090	0,012	0,015	0,018	0,024	0,030	0,036	0,055	0,060	0,075	0,090	320 (280 — 330)	
H12	M/A	0,050	0,44	0,0055	0,0080	0,011	0,014	0,016	0,022	0,028	0,032	0,050	0,055	0,060	0,065	295 (260 — 330)	
H21	M/A	0,050	0,44	0,0055	0,0080	0,011	0,014	0,016	0,022	0,028	0,032	0,050	0,055	0,060	0,065	250 (220 — 280)	
H31	M/A	0,050	0,44	0,0046	0,0070	0,0095	0,012	0,014	0,019	0,024	0,028	0,036	0,040	0,044	0,048	190 (170 — 215)	
GR1	A	0,50	0,50	0,0030	0,0044	0,0060	0,0075	0,0090	0,012	0,015	0,018	0,024	0,025	0,028	0,032	405 (350 — 460)	

Table based on LV1, please recalc based on length version chosen. See page(s) 411-418

SMG = Seco material group

Coolant = A=air D=dry E=emulsion M=mist spray

v_c = m/min

f_z = mm

a_p (mm)/DC (mm)= factor

a_g (mm)/DC (mm)= factor

All cutting data are target values

Cutting data – JME542/JME562 Slot milling

SMG		a _p /DC	f _z														v _c
			0,2	0,3	0,4	0,5	0,6	0,8	1,0	1,2	1,8	2,0	2,5	3,0			
P1	M/E/A	0,32	0,0026	0,0040	0,0050	0,0065	0,0080	0,010	0,013	0,016	0,024	0,026	0,032	0,040	255 (230 – 285)		
P2	M/E/A	0,32	0,0026	0,0040	0,0050	0,0065	0,0080	0,010	0,013	0,016	0,024	0,026	0,032	0,040	250 (220 – 275)		
P3	M/E/A	0,32	0,0026	0,0040	0,0050	0,0065	0,0080	0,010	0,013	0,016	0,024	0,026	0,032	0,040	215 (190 – 235)		
P4	M/E/A	0,32	0,0026	0,0040	0,0050	0,0065	0,0080	0,010	0,013	0,016	0,024	0,026	0,032	0,040	190 (170 – 210)		
P5	M/E/A	0,32	0,0026	0,0040	0,0050	0,0065	0,0080	0,010	0,013	0,016	0,024	0,026	0,032	0,040	180 (160 – 200)		
P6	M/E/A	0,32	0,0026	0,0040	0,0050	0,0065	0,0080	0,010	0,013	0,016	0,024	0,026	0,032	0,040	200 (180 – 225)		
P7	M/E/A	0,32	0,0026	0,0040	0,0050	0,0065	0,0080	0,010	0,013	0,016	0,024	0,026	0,032	0,040	190 (170 – 210)		
P8	M/E/A	0,32	0,0026	0,0040	0,0050	0,0065	0,0080	0,010	0,013	0,016	0,024	0,026	0,032	0,040	180 (160 – 200)		
P11	M/E/A	0,32	0,0026	0,0040	0,0050	0,0065	0,0080	0,010	0,013	0,016	0,024	0,026	0,032	0,040	185 (165 – 205)		
P12	M/E/A	0,32	0,0022	0,0032	0,0042	0,0055	0,0065	0,0085	0,011	0,013	0,018	0,019	0,022	0,024	110 (100 – 120)		
M1	E/M/A	0,32	0,0026	0,0040	0,0050	0,0065	0,0080	0,010	0,013	0,016	0,024	0,026	0,032	0,040	135 (110 – 160)		
M2	E/M/A	0,32	0,0026	0,0040	0,0050	0,0065	0,0080	0,010	0,013	0,016	0,024	0,026	0,032	0,040	110 (90 – 130)		
M3	E/M/A	0,32	0,0026	0,0040	0,0050	0,0065	0,0080	0,010	0,013	0,016	0,024	0,026	0,032	0,040	110 (90 – 130)		
M4	E/M/A	0,32	0,0026	0,0040	0,0050	0,0065	0,0080	0,010	0,013	0,016	0,024	0,026	0,032	0,036	80 (70 – 100)		
M5	E/M/A	0,32	0,0026	0,0040	0,0050	0,0065	0,0080	0,010	0,013	0,016	0,024	0,026	0,032	0,036	70 (55 – 80)		
N1	E/M/A	0,24	0,0026	0,0040	0,0050	0,0065	0,0080	0,010	0,013	0,016	0,024	0,026	0,032	0,040	400 (350 – 450)		
N2	E/M/A	0,24	0,0026	0,0040	0,0050	0,0065	0,0080	0,010	0,013	0,016	0,024	0,026	0,032	0,040	400 (350 – 450)		
N3	E/M/A	0,24	0,0026	0,0040	0,0050	0,0065	0,0080	0,010	0,013	0,016	0,024	0,026	0,032	0,040	265 (235 – 300)		
N11	E/M/A	0,24	0,0040	0,0060	0,0080	0,010	0,012	0,016	0,020	0,024	0,036	0,040	0,048	0,055	350 (300 – 400)		
S11	E/M/A	0,36	0,0026	0,0040	0,0050	0,0065	0,0080	0,010	0,013	0,016	0,024	0,026	0,032	0,040	180 (155 – 205)		
S12	E/M/A	0,36	0,0026	0,0040	0,0050	0,0065	0,0080	0,010	0,013	0,016	0,024	0,026	0,032	0,040	140 (120 – 130)		
S13	E/M/A	0,36	0,0026	0,0040	0,0050	0,0065	0,0080	0,010	0,013	0,016	0,024	0,026	0,032	0,036	110 (90 – 125)		
H3	M/A	0,095	0,0024	0,0036	0,0048	0,0060	0,0070	0,0095	0,012	0,014	0,022	0,024	0,030	0,036	80 (60 – 100)		
H5	M/A	0,20	0,0026	0,0040	0,0050	0,0065	0,0080	0,010	0,013	0,016	0,024	0,026	0,032	0,040	160 (140 – 180)		
H7	M/A	0,095	0,0024	0,0036	0,0048	0,0060	0,0070	0,0095	0,012	0,014	0,022	0,024	0,030	0,036	80 (60 – 100)		
H8	M/A	0,20	0,0024	0,0036	0,0048	0,0060	0,0070	0,0095	0,012	0,014	0,022	0,024	0,026	0,030	160 (140 – 180)		
H11	M/A	0,20	0,0026	0,0040	0,0050	0,0065	0,0080	0,010	0,013	0,016	0,024	0,026	0,032	0,040	205 (180 – 230)		
H12	M/A	0,20	0,0024	0,0036	0,0048	0,0060	0,0070	0,0095	0,012	0,014	0,022	0,024	0,026	0,030	190 (165 – 210)		
H21	M/A	0,20	0,0024	0,0036	0,0048	0,0060	0,0070	0,0095	0,012	0,014	0,022	0,024	0,026	0,030	160 (140 – 180)		
H31	M/A	0,20	0,0020	0,0030	0,0042	0,0050	0,0060	0,0080	0,010	0,012	0,017	0,018	0,020	0,022	125 (110 – 140)		
GR1	A	0,50	0,0020	0,0030	0,0040	0,0050	0,0060	0,0080	0,010	0,012	0,018	0,020	0,025	0,030	350 (300 – 400)		

Table based on LV1, please recalc based on length version chosen. See page(s) 411-418

SMG = Seco material group

Coolant = A=air D=dry E=emulsion M=mist spray

v_c = m/min

f_z = mm

a_p (mm)/DC (mm)= factor

a_e (mm)/DC (mm)= factor

All cutting data are target values

JMB542 – Miniature – Universal – Ball nose – 2 Flutes – DMM 4 – Cylindrical



Tolerances:
 Run-out=<0,007 mm
 DMM= h5
 DC= Ø0,-0.01 mm
 RE= ±0,005 mm

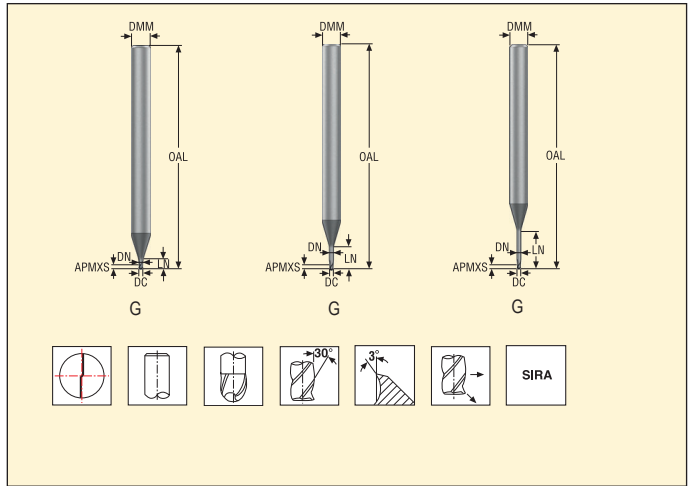

Ordering and Product No.	Designation	Length index	Tool shape	Dimensions in mm								PCEDC	CA	Max. cut depth rel. to $\alpha\eta$ ($\alpha\eta$, ref)*					
				DC	DMM	APMXS	OAL	LN	DN	RE	WDX0			WDX05	WDX1	WDX15	WDX2	WDX3	
03171221	JMB542002G1B.0Z2-SIRA	1	G	0,2	4	0,2	45	0,4	0,18	0,1	2	14,57	0,56	0,62	0,67	0,73	0,78	0,88	
03171222	JMB542003G1B.0Z2-SIRA	1	G	0,3	4	0,3	45	0,6	0,28	0,15	2	14,24	0,76	0,83	0,9	0,96	1,02	1,13	
03171223	JMB542004G1B.0Z2-SIRA	1	G	0,4	4	0,4	45	0,8	0,37	0,2	2	13,81	1,12	1,18	1,24	1,29	1,35	1,45	
03171224	JMB542005G1B.0Z2-SIRA	1	G	0,5	4	0,5	45	1,0	0,46	0,25	2	13,47	1,32	1,39	1,45	1,51	1,57	1,68	
03171225	JMB542006G1B.0Z2-SIRA	1	G	0,6	4	0,6	45	1,2	0,56	0,3	2	13,14	1,52	1,59	1,67	1,73	1,8	1,92	
03171226	JMB542008G1B.0Z2-SIRA	1	G	0,8	4	0,8	45	1,6	0,76	0,4	2	12,46	1,92	2,01	2,1	2,17	2,25	2,39	
03171228	JMB542010G1B.0Z2-SIRA	1	G	1,0	4	1,0	50	2,0	0,95	0,5	2	11,77	2,23	2,43	2,52	2,61	2,69	2,85	
03171229	JMB542012G1B.0Z2-SIRA	1	G	1,2	4	1,2	50	2,4	1,15	0,6	2	11,07	2,72	2,84	2,95	3,04	3,13	3,32	
03171230	JMB542015G1B.0Z2-SIRA	1	G	1,5	4	1,5	50	3,0	1,45	0,75	2	9,88	3,47	3,59	3,69	3,79	3,89	4,13	
03171231	JMB542005G3B.0Z2-SIRA	3	G	0,5	4	0,5	45	2,5	0,46	0,25	2	11,25	2,82	2,97	3,09	3,19	3,29	3,52	
03171233	JMB542006G3B.0Z2-SIRA	3	G	0,6	4	0,6	45	3,0	0,56	0,3	2	10,61	3,32	3,49	3,62	3,74	3,86	4,12	
03171234	JMB542008G3B.0Z2-SIRA	3	G	0,8	4	0,8	45	4,0	0,76	0,4	2	9,44	4,32	4,53	4,68	4,83	4,98	5,32	
03171235	JMB542010G3B.0Z2-SIRA	3	G	1,0	4	1,0	50	5,0	0,95	0,5	2	8,38	5,32	5,56	5,74	5,92	6,11	6,53	
03171236	JMB542012G3B.0Z2-SIRA	3	G	1,2	4	1,2	50	6,0	1,15	0,6	2	7,44	6,32	6,6	6,8	7,01	7,23	7,73	
03171237	JMB542015G3B.0Z2-SIRA	3	G	1,5	4	1,5	50	7,5	1,45	0,75	2	6,13	7,97	8,24	8,48	8,74	9,02	9,64	
03171238	JMB542020G3B.0Z2-SIRA	3	G	2,0	4	2,0	50	10,0	1,94	1,0	2	4,4	10,47	10,81	11,13	11,47	11,83	12,64	
03171239	JMB542025G3B.0Z2-SIRA	3	G	2,5	4	2,5	50	12,5	2,4	1,25	2	3,0	12,97	13,38	13,77	14,19	14,64	∞	
03171240	JMB542030G3B.0Z2-SIRA	3	G	3,0	4	3,0	60	15,0	2,85	1,5	2	1,81	15,68	16,13	16,6	17,11	∞	∞	
03171241	JMB542005G4B.0Z2-SIRA	4	G	0,5	4	0,5	45	4,0	0,46	0,25	2	9,65	4,32	4,53	4,69	4,84	5,0	5,36	
03171242	JMB542006G4B.0Z2-SIRA	4	G	0,6	4	0,6	45	5,0	0,56	0,3	2	8,74	5,32	5,57	5,75	5,94	6,13	6,57	
03171243	JMB542008G4B.0Z2-SIRA	4	G	0,8	4	0,8	45	7,0	0,76	0,4	2	7,23	7,32	7,64	7,88	8,13	8,4	8,99	
03171244	JMB542010G4B.0Z2-SIRA	4	G	1,0	4	1,0	50	8,5	0,95	0,5	2	6,27	8,82	9,19	9,47	9,77	10,09	10,81	
03171245	JMB542012G4B.0Z2-SIRA	4	G	1,2	4	1,2	50	10,0	1,15	0,6	2	5,44	10,32	10,73	11,06	11,41	11,79	12,62	
03171246	JMB542015G4B.0Z2-SIRA	4	G	1,5	4	1,5	50	12,0	1,45	0,75	2	4,44	12,47	12,88	13,27	13,69	14,14	15,14	
03171247	JMB542020G4B.0Z2-SIRA	4	G	2,0	4	2,0	60	16,0	1,94	1,0	2	3,02	16,47	17,0	17,51	18,07	18,66	19,98	
03171248	JMB542025G4B.0Z2-SIRA	4	G	2,5	4	2,5	60	20,0	2,4	1,25	2	1,97	20,47	21,11	21,76	22,45	∞	∞	
03171249	JMB542030G4B.0Z2-SIRA	4	G	3,0	4	3,0	70	24,0	2,85	1,5	2	1,16	24,68	25,41	26,19	∞	∞	∞	
03171250	JMB542015G5B.0Z2-SIRA	5	G	1,5	4	1,5	60	15,0	1,45	0,75	2	3,75	15,47	15,97	16,47	16,99	17,56	18,81	
03171251	JMB542020G5B.0Z2-SIRA	5	G	2,0	4	2,0	60	20,0	1,94	1,0	2	2,5	20,47	21,12	21,77	22,47	23,22	∞	
03171252	JMB542025G5B.0Z2-SIRA	5	G	2,5	4	2,5	70	25,0	2,4	1,25	2	1,61	25,47	26,27	27,08	27,95	∞	∞	
03171253	JMB542030G5B.0Z2-SIRA	5	G	3,0	4	3,0	70	30,0	2,85	1,5	2	0,93	30,68	31,6	∞	∞	∞	∞	
03171254	JMB542015G6B.0Z2-SIRA	6	G	1,5	4	1,5	70	22,5	1,45	0,75	2	2,7	22,97	23,71	24,45	25,25	26,1	∞	
03171255	JMB542020G6B.0Z2-SIRA	6	G	2,0	4	2,0	70	30,0	1,94	1,0	2	1,74	30,47	31,43	32,42	33,48	∞	∞	
03171256	JMB542025G6B.0Z2-SIRA	6	G	2,5	4	2,5	80	37,5	2,4	1,25	2	1,1	37,97	39,16	40,39	∞	∞	∞	
03171257	JMB542030G6B.0Z2-SIRA	6	G	3,0	4	3,0	90	45,0	2,85	1,5	2	0,63	45,68	47,07	∞	∞	∞	∞	

Stock standard. Subject to change refer to current price- and stock-list

Cutting data – JMB542/JMB562 Slot milling

SMG		a _p /DC	f _z														v _c
			0,2	0,3	0,4	0,5	0,6	0,8	1,0	1,2	1,8	2,0	2,5	3,0			
P1	M/E/A	0,32	0,0026	0,0040	0,0050	0,0065	0,0080	0,010	0,013	0,016	0,024	0,026	0,032	0,040	255 (220 – 285)		
P2	M/E/A	0,32	0,0026	0,0040	0,0050	0,0065	0,0080	0,010	0,013	0,016	0,024	0,026	0,032	0,040	250 (220 – 280)		
P3	M/E/A	0,32	0,0026	0,0040	0,0050	0,0065	0,0080	0,010	0,013	0,016	0,024	0,026	0,032	0,040	215 (190 – 240)		
P4	M/E/A	0,32	0,0026	0,0040	0,0050	0,0065	0,0080	0,010	0,013	0,016	0,024	0,026	0,032	0,040	190 (170 – 200)		
P5	M/E/A	0,32	0,0026	0,0040	0,0050	0,0065	0,0080	0,010	0,013	0,016	0,024	0,026	0,032	0,040	180 (160 – 200)		
P6	M/E/A	0,32	0,0026	0,0040	0,0050	0,0065	0,0080	0,010	0,013	0,016	0,024	0,026	0,032	0,040	200 (180 – 225)		
P7	M/E/A	0,32	0,0026	0,0040	0,0050	0,0065	0,0080	0,010	0,013	0,016	0,024	0,026	0,032	0,040	190 (170 – 210)		
P8	M/E/A	0,32	0,0026	0,0040	0,0050	0,0065	0,0080	0,010	0,013	0,016	0,024	0,026	0,032	0,040	180 (160 – 200)		
P11	M/E/A	0,32	0,0026	0,0040	0,0050	0,0065	0,0080	0,010	0,013	0,016	0,024	0,026	0,032	0,040	185 (165 – 205)		
P12	M/E/A	0,32	0,0022	0,0032	0,0042	0,0055	0,0065	0,0085	0,011	0,013	0,018	0,019	0,022	0,024	110 (100 – 120)		
M1	E/M/A	0,32	0,0026	0,0040	0,0050	0,0065	0,0080	0,010	0,013	0,016	0,024	0,026	0,032	0,040	135 (110 – 160)		
M2	E/M/A	0,32	0,0026	0,0040	0,0050	0,0065	0,0080	0,010	0,013	0,016	0,024	0,026	0,032	0,040	110 (90 – 130)		
M3	E/M/A	0,32	0,0026	0,0040	0,0050	0,0065	0,0080	0,010	0,013	0,016	0,024	0,026	0,032	0,040	110 (90 – 130)		
M4	E/M/A	0,32	0,0026	0,0040	0,0050	0,0065	0,0080	0,010	0,013	0,016	0,024	0,026	0,032	0,036	80 (70 – 100)		
M5	E/M/A	0,32	0,0026	0,0040	0,0050	0,0065	0,0080	0,010	0,013	0,016	0,024	0,026	0,032	0,036	70 (55 – 80)		
N1	E/M/A	0,24	0,0026	0,0040	0,0050	0,0065	0,0080	0,010	0,013	0,016	0,024	0,026	0,032	0,040	400 (350 – 450)		
N2	E/M/A	0,26	0,0026	0,0040	0,0050	0,0065	0,0080	0,010	0,013	0,016	0,024	0,026	0,032	0,040	400 (350 – 450)		
N3	E/M/A	0,26	0,0026	0,0040	0,0050	0,0065	0,0080	0,010	0,013	0,016	0,024	0,026	0,032	0,040	265 (235 – 300)		
N11	E/M/A	0,24	0,0040	0,0060	0,0080	0,010	0,012	0,016	0,020	0,024	0,036	0,040	0,048	0,055	350 (300 – 400)		
S11	E/M/A	0,34	0,0026	0,0040	0,0050	0,0065	0,0080	0,010	0,013	0,016	0,024	0,026	0,032	0,040	180 (160 – 210)		
S12	E/M/A	0,34	0,0026	0,0040	0,0050	0,0065	0,0080	0,010	0,013	0,016	0,024	0,026	0,032	0,040	140 (120 – 160)		
S13	E/M/A	0,34	0,0026	0,0040	0,0050	0,0065	0,0080	0,010	0,013	0,016	0,024	0,026	0,032	0,036	110 (95 – 125)		
H3	M/A	0,10	0,0024	0,0036	0,0048	0,0060	0,0070	0,0095	0,012	0,014	0,022	0,024	0,030	0,036	80 (60 – 100)		
H5	M/A	0,20	0,0026	0,0040	0,0050	0,0065	0,0080	0,010	0,013	0,016	0,024	0,026	0,032	0,040	160 (140 – 180)		
H7	M/A	0,10	0,0024	0,0036	0,0048	0,0060	0,0070	0,0095	0,012	0,014	0,022	0,024	0,030	0,036	80 (60 – 100)		
H8	M/A	0,20	0,0024	0,0036	0,0048	0,0060	0,0070	0,0095	0,012	0,014	0,022	0,024	0,026	0,030	160 (140 – 180)		
H11	M/A	0,20	0,0026	0,0040	0,0050	0,0065	0,0080	0,010	0,013	0,016	0,024	0,026	0,032	0,040	205 (180 – 230)		
H12	M/A	0,20	0,0024	0,0036	0,0048	0,0060	0,0070	0,0095	0,012	0,014	0,022	0,024	0,026	0,030	190 (165 – 210)		
H21	M/A	0,20	0,0024	0,0036	0,0048	0,0060	0,0070	0,0095	0,012	0,014	0,022	0,024	0,026	0,030	160 (140 – 180)		
H31	M/A	0,20	0,0020	0,0030	0,0042	0,0050	0,0060	0,0080	0,010	0,012	0,017	0,018	0,020	0,022	120 (110 – 140)		
GR1	A	0,50	0,0020	0,0030	0,0040	0,0050	0,0060	0,0080	0,010	0,012	0,018	0,020	0,025	0,030	350 (300 – 400)		

Table based on LV1, please recalc based on length version chosen. See page(s) 411-418

SMG = Seco material group

Coolant = A=air D=dry E=emulsion M=mist spray

v_c = m/min

f_z = mm

a_p (mm)/DC (mm)= factor

a_e (mm)/DC (mm)= factor

All cutting data are target values

Cutting data – JMB542/JMB562 Copy milling roughing

SMG		a _g /DC	a _p /DC	f _z												v _c	
				0,2	0,3	0,4	0,5	0,6	0,8	1,0	1,2	1,8	2,0	2,5	3,0		
P1	M/E/A	0,050	0,60	0,0040	0,0060	0,0080	0,010	0,012	0,016	0,020	0,024	0,036	0,040	0,050	0,060	365 (325 — 405)	
P2	M/E/A	0,050	0,60	0,0040	0,0060	0,0080	0,010	0,012	0,016	0,020	0,024	0,036	0,040	0,050	0,060	355 (315 — 395)	
P3	M/E/A	0,050	0,60	0,0040	0,0060	0,0080	0,010	0,012	0,016	0,020	0,024	0,036	0,040	0,050	0,060	305 (270 — 340)	
P4	M/E/A	0,050	0,60	0,0040	0,0060	0,0080	0,010	0,012	0,016	0,020	0,024	0,036	0,040	0,050	0,060	270 (240 — 300)	
P5	M/E/A	0,050	0,60	0,0040	0,0060	0,0080	0,010	0,012	0,016	0,020	0,024	0,036	0,040	0,050	0,060	255 (230 — 285)	
P6	M/E/A	0,050	0,60	0,0040	0,0060	0,0080	0,010	0,012	0,016	0,020	0,024	0,036	0,040	0,050	0,060	290 (260 — 320)	
P7	M/E/A	0,050	0,60	0,0040	0,0060	0,0080	0,010	0,012	0,016	0,020	0,024	0,036	0,040	0,050	0,060	270 (240 — 300)	
P8	M/E/A	0,050	0,60	0,0040	0,0060	0,0080	0,010	0,012	0,016	0,020	0,024	0,036	0,040	0,050	0,060	255 (230 — 285)	
P11	M/E/A	0,050	0,60	0,0040	0,0060	0,0080	0,010	0,012	0,016	0,020	0,024	0,036	0,040	0,050	0,060	265 (235 — 290)	
P12	M/E/A	0,050	0,60	0,0032	0,0048	0,0065	0,0080	0,010	0,013	0,016	0,020	0,028	0,030	0,034	0,038	155 (140 — 175)	
M1	E/M/A	0,024	0,60	0,0040	0,0060	0,0080	0,010	0,012	0,016	0,020	0,024	0,036	0,040	0,050	0,060	215 (180 — 255)	
M2	E/M/A	0,024	0,60	0,0040	0,0060	0,0080	0,010	0,012	0,016	0,020	0,024	0,036	0,040	0,050	0,060	175 (145 — 205)	
M3	E/M/A	0,024	0,60	0,0040	0,0060	0,0080	0,010	0,012	0,016	0,020	0,024	0,036	0,040	0,050	0,060	175 (145 — 205)	
M4	E/M/A	0,024	0,60	0,0040	0,0060	0,0080	0,010	0,012	0,016	0,020	0,024	0,036	0,040	0,050	0,060	130 (110 — 155)	
M5	E/M/A	0,024	0,60	0,0040	0,0060	0,0080	0,010	0,012	0,016	0,020	0,024	0,036	0,040	0,050	0,060	110 (90 — 130)	
N1	E/M/A	0,10	0,75	0,0040	0,0060	0,0080	0,010	0,012	0,016	0,020	0,024	0,032	0,034	0,040	0,042	485 (425 — 545)	
N2	E/M/A	0,10	0,75	0,0040	0,0060	0,0080	0,010	0,012	0,016	0,020	0,024	0,034	0,036	0,040	0,044	485 (425 — 550)	
N3	E/M/A	0,10	0,75	0,0040	0,0060	0,0080	0,010	0,012	0,016	0,020	0,024	0,034	0,036	0,040	0,044	325 (285 — 365)	
N11	E/M/A	0,10	0,75	0,0050	0,0075	0,010	0,012	0,015	0,020	0,025	0,030	0,040	0,044	0,050	0,055	430 (370 — 490)	
S11	E/M/A	0,024	0,60	0,0040	0,0060	0,0080	0,010	0,012	0,016	0,020	0,024	0,036	0,040	0,050	0,060	290 (250 — 335)	
S12	E/M/A	0,024	0,60	0,0040	0,0060	0,0080	0,010	0,012	0,016	0,020	0,024	0,036	0,040	0,050	0,060	225 (195 — 260)	
S13	E/M/A	0,024	0,60	0,0040	0,0060	0,0080	0,010	0,012	0,016	0,020	0,024	0,036	0,040	0,050	0,060	175 (150 — 200)	
H3	M/A	0,050	0,30	0,0030	0,0044	0,0060	0,0075	0,0090	0,012	0,015	0,017	0,024	0,025	0,028	0,030	120 (90 — 145)	
H5	M/A	0,050	0,44	0,0040	0,0060	0,0080	0,010	0,012	0,016	0,020	0,024	0,036	0,040	0,046	0,050	235 (210 — 260)	
H7	M/A	0,050	0,30	0,0030	0,0044	0,0060	0,0075	0,0090	0,012	0,015	0,017	0,024	0,025	0,028	0,030	120 (90 — 150)	
H8	M/A	0,050	0,44	0,0032	0,0050	0,0065	0,0085	0,010	0,013	0,016	0,020	0,026	0,028	0,032	0,034	235 (205 — 265)	
H11	M/A	0,050	0,44	0,0040	0,0060	0,0080	0,010	0,012	0,016	0,020	0,024	0,036	0,040	0,046	0,050	300 (265 — 340)	
H12	M/A	0,050	0,44	0,0032	0,0050	0,0065	0,0085	0,010	0,013	0,016	0,020	0,026	0,028	0,032	0,034	275 (240 — 310)	
H21	M/A	0,050	0,44	0,0032	0,0050	0,0065	0,0085	0,010	0,013	0,016	0,020	0,026	0,028	0,032	0,034	235 (205 — 265)	
H31	M/A	0,050	0,44	0,0025	0,0036	0,0050	0,0060	0,0075	0,010	0,012	0,015	0,020	0,020	0,024	0,026	175 (155 — 200)	
GR1	A	0,50	0,50	0,0030	0,0044	0,0060	0,0075	0,0090	0,012	0,015	0,018	0,024	0,025	0,028	0,032	405 (350 — 460)	

Table based on LV1, please recalc based on length version chosen. See page(s) 411-418

SMG = Seco material group

Coolant = A=air D=dry E=emulsion M=mist spray

v_c = m/min

f_z = mm

a_p (mm)/DC (mm)= factor

a_g (mm)/DC (mm)= factor

All cutting data are target values

JMB562 - Miniature - Universal - Ball nose - 2 Flutes - DMM6 - Cylindrical



Tolerances:
 Run-out=<0,007 mm
 DMM= h5
 DC= Ø0,-0,01 mm
 RE= ±0,005 mm

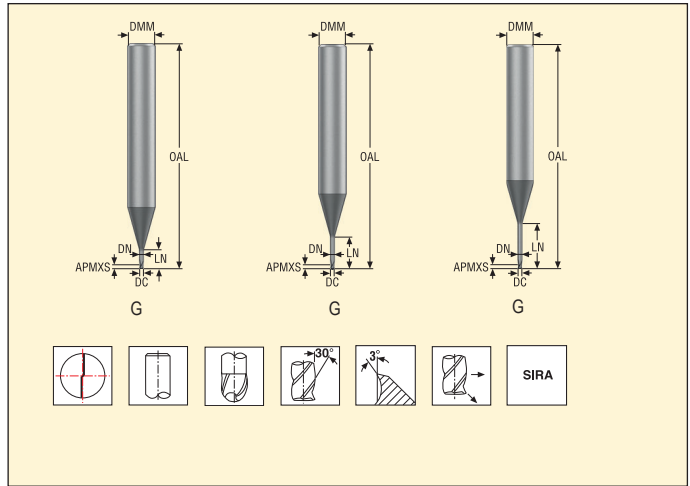

Ordering and Product No.	Designation	Length index	Tool shape	Dimensions in mm							PCEDC	CA	Max. cut depth rel. to αη (αη, ref)*					
				DC	DMM	APMXS	OAL	LN	DN	RE			WDX0	WDX05	WDX1	WDX15	WDX2	WDX3
03171261	JMB562005G2B.0Z2-SIRA	2	G	0,5	6	0,5	50	1,5	0,46	0,25	2	13,69	1,82	1,91	2,0	2,08	2,15	2,3
03171262	JMB562006G2B.0Z2-SIRA	2	G	0,6	6	0,6	50	2,0	0,56	0,3	2	13,13	2,32	2,44	2,54	2,63	2,72	2,9
03171263	JMB562008G2B.0Z2-SIRA	2	G	0,8	6	0,8	50	2,5	0,76	0,4	2	12,6	2,82	2,96	3,07	3,18	3,27	3,49
03171264	JMB562010G2B.0Z2-SIRA	2	G	1,0	6	1,0	50	4,0	0,95	0,5	2	11,15	4,32	4,52	4,68	4,68	4,97	5,3
03171265	JMB562012G2B.0Z2-SIRA	2	G	1,2	6	1,2	50	4,5	1,15	0,6	2	10,67	4,82	5,04	5,2	5,36	5,52	5,89
03171266	JMB562015G2B.0Z2-SIRA	2	G	1,5	6	1,5	50	5,0	1,45	0,75	2	10,07	5,47	5,66	5,82	5,99	6,17	6,58
03171267	JMB562018G2B.0Z2-SIRA	2	G	1,8	6	1,8	50	5,4	1,75	0,9	2	9,61	5,87	6,07	6,23	6,41	6,61	7,03
03171268	JMB562020G2B.0Z2-SIRA	2	G	2,0	6	2,0	50	6,0	1,94	1,0	2	9,05	6,47	6,68	6,87	7,06	7,28	7,75
03171269	JMB562025G2B.0Z2-SIRA	2	G	2,5	6	2,5	60	7,5	2,4	1,25	2	7,71	7,97	8,22	8,45	8,69	8,95	9,53
03171270	JMB562030G2B.0Z2-SIRA	2	G	3,0	6	3,0	60	9,0	2,85	1,5	2	6,35	9,68	9,94	10,21	10,51	10,82	11,52
03171271	JMB562005G4B.0Z2-SIRA	4	G	0,5	6	0,5	50	3,5	0,46	0,25	2	11,7	3,82	4,01	4,16	4,29	4,43	4,74
03171272	JMB562006G4B.0Z2-SIRA	4	G	0,6	6	0,6	50	4,2	0,56	0,3	2	11,1	4,52	4,74	4,9	5,06	5,22	5,59
03171273	JMB562008G4B.0Z2-SIRA	4	G	0,8	6	0,8	50	5,6	0,76	0,4	2	10,02	5,92	6,19	6,39	6,59	6,8	7,28
03171274	JMB562010G4B.0Z2-SIRA	4	G	1,0	6	1,0	50	7,0	0,95	0,5	2	9,06	7,32	7,64	7,87	8,12	8,38	8,97
03171275	JMB562012G4B.0Z2-SIRA	4	G	1,2	6	1,2	50	8,4	1,15	0,6	2	8,22	8,72	9,08	9,35	9,65	9,96	10,66
03171276	JMB562015G4B.0Z2-SIRA	4	G	1,5	6	1,5	50	10,5	1,45	0,75	2	7,07	10,97	11,33	11,67	12,04	12,43	13,31
03171277	JMB562020G4B.0Z2-SIRA	4	G	2,0	6	2,0	60	14,0	1,94	1,0	2	5,57	14,47	14,93	15,38	15,87	16,38	17,54
03171278	JMB562025G4B.0Z2-SIRA	4	G	2,5	6	2,5	65	17,5	2,4	1,25	2	4,38	17,97	18,53	19,1	19,69	20,34	21,76
03171279	JMB562030G4B.0Z2-SIRA	4	G	3,0	6	3,0	70	21,0	2,85	1,5	2	3,38	21,68	22,32	22,99	23,71	24,49	26,21
03171280	JMB562005G5B.0Z2-SIRA	5	G	0,5	6	0,5	50	5,0	0,46	0,25	2	10,54	5,32	5,57	5,76	5,94	6,14	6,58
03171281	JMB562006G5B.0Z2-SIRA	5	G	0,6	6	0,6	50	6,0	0,56	0,3	2	9,85	6,32	6,61	6,82	7,04	7,27	7,79
03171282	JMB562008G5B.0Z2-SIRA	5	G	0,8	6	0,8	50	8,0	0,76	0,4	2	8,64	8,32	8,67	8,94	9,23	9,54	10,22
03171283	JMB562010G5B.0Z2-SIRA	5	G	1,0	6	1,0	50	10,0	0,95	0,5	2	7,63	10,32	10,73	11,06	11,42	11,8	12,64
03171284	JMB562012G5B.0Z2-SIRA	5	G	1,2	6	1,2	50	12,0	1,15	0,6	2	6,77	12,32	12,79	13,19	13,61	14,06	15,07
03171285	JMB562015G5B.0Z2-SIRA	5	G	1,5	6	1,5	60	15,0	1,45	0,75	2	5,68	15,47	15,97	16,47	16,99	17,56	18,81
03171287	JMB562020G5B.0Z2-SIRA	5	G	2,0	6	2,0	60	20,0	1,94	1,0	2	4,32	20,47	21,12	21,77	22,47	23,22	24,88
03171288	JMB562025G5B.0Z2-SIRA	5	G	2,5	6	2,5	70	25,0	2,4	1,25	2	3,3	25,47	26,27	27,08	27,95	28,88	30,94
03171289	JMB562030G5B.0Z2-SIRA	5	G	3,0	6	3,0	70	30,0	2,85	1,5	2	2,5	30,68	31,6	32,58	33,62	34,73	∞

Stock standard. Subject to change refer to current price- and stock-list

JMB562 - Miniature - Universal - Ball nose - 2 Flutes - DMM 6 - Cylindrical



Tolerances:
 Run-out=<0,007 mm
 DMM= h5
 DC= Ø0,-0.01 mm
 RE= ±0,005 mm

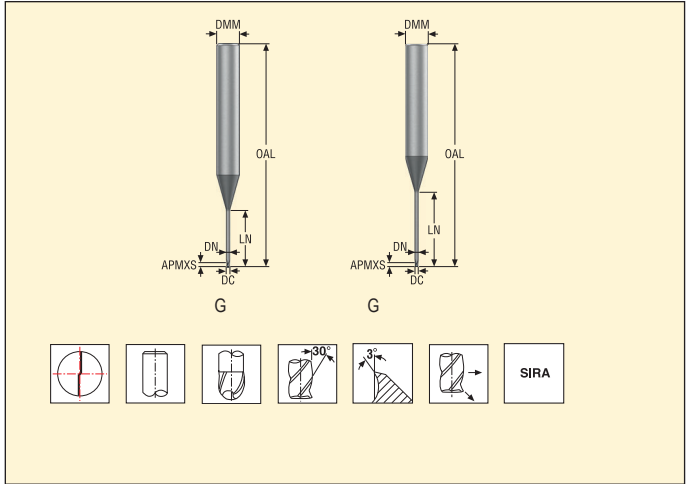

Ordering and Product No.	Designation	Length index	Tool shape	Dimensions in mm								PCEDC	CA	Max. cut depth rel. to α_1 (α_{1r} , ref)*					
				DC	DMM	APMXS	OAL	LN	DN	RE	WDX0			WDX05	WDX1	WDX15	WDX2	WDX3	
03171290	JMB562010G6B.0Z2-SIRA	6	G	1,0	6	1,0	60	15,0	0,95	0,5	2	6,04	15,32	15,89	16,39	16,92	17,49	18,76	
03171291	JMB562012G6B.0Z2-SIRA	6	G	1,2	6	1,2	60	18,0	1,15	0,6	2	5,24	18,32	18,98	19,58	20,21	20,89	22,41	
03171292	JMB562015G6B.0Z2-SIRA	6	G	1,5	6	1,5	70	22,5	1,45	0,75	2	4,28	22,97	23,71	24,45	25,25	26,1	27,99	
03171293	JMB562020G6B.0Z2-SIRA	6	G	2,0	6	2,0	80	30,0	1,94	1,0	2	3,14	30,47	31,43	32,42	33,48	34,6	37,11	
03171294	JMB562025G6B.0Z2-SIRA	6	G	2,5	6	2,5	80	37,5	2,4	1,25	2	2,34	37,97	39,16	40,39	41,7	43,11	∞	
03171295	JMB562030G6B.0Z2-SIRA	6	G	3,0	6	3,0	90	45,0	2,85	1,5	2	1,74	45,68	47,07	48,55	50,13	∞	∞	
03171296	JMB562010G7B.0Z2-SIRA	7	G	1,0	6	1,0	60	20,0	0,95	0,5	2	4,99	20,32	21,05	21,71	22,42	23,19	24,88	
03171297	JMB562012G7B.0Z2-SIRA	7	G	1,2	6	1,2	80	24,0	1,15	0,6	2	4,27	24,32	25,17	25,97	26,82	27,73	29,75	
03171298	JMB562015G7B.0Z2-SIRA	7	G	1,5	6	1,5	80	30,0	1,45	0,75	2	3,43	30,47	31,44	32,44	33,5	34,64	37,17	
03171299	JMB562020G7B.0Z2-SIRA	7	G	2,0	6	2,0	80	40,0	1,94	1,0	2	2,47	40,47	41,75	43,07	44,48	45,99	∞	
03171300	JMB562025G7B.0Z2-SIRA	7	G	2,5	6	2,5	90	50,0	2,4	1,25	2	1,81	50,47	52,05	53,7	55,46	∞	∞	
03171301	JMB562030G7B.0Z2-SIRA	7	G	3,0	6	3,0	100	60,0	2,85	1,5	2	1,34	60,68	62,54	64,52	∞	∞	∞	

Stock standard. Subject to change refer to current price- and stock-list

Cutting data – JMB542/JMB562 Slot milling

SMG		a _p /DC	f _z														v _c
			0,2	0,3	0,4	0,5	0,6	0,8	1,0	1,2	1,8	2,0	2,5	3,0			
P1	M/E/A	0,32	0,0026	0,0040	0,0050	0,0065	0,0080	0,010	0,013	0,016	0,024	0,026	0,032	0,040	255 (220 – 285)		
P2	M/E/A	0,32	0,0026	0,0040	0,0050	0,0065	0,0080	0,010	0,013	0,016	0,024	0,026	0,032	0,040	250 (220 – 280)		
P3	M/E/A	0,32	0,0026	0,0040	0,0050	0,0065	0,0080	0,010	0,013	0,016	0,024	0,026	0,032	0,040	215 (190 – 240)		
P4	M/E/A	0,32	0,0026	0,0040	0,0050	0,0065	0,0080	0,010	0,013	0,016	0,024	0,026	0,032	0,040	190 (170 – 200)		
P5	M/E/A	0,32	0,0026	0,0040	0,0050	0,0065	0,0080	0,010	0,013	0,016	0,024	0,026	0,032	0,040	180 (160 – 200)		
P6	M/E/A	0,32	0,0026	0,0040	0,0050	0,0065	0,0080	0,010	0,013	0,016	0,024	0,026	0,032	0,040	200 (180 – 225)		
P7	M/E/A	0,32	0,0026	0,0040	0,0050	0,0065	0,0080	0,010	0,013	0,016	0,024	0,026	0,032	0,040	190 (170 – 210)		
P8	M/E/A	0,32	0,0026	0,0040	0,0050	0,0065	0,0080	0,010	0,013	0,016	0,024	0,026	0,032	0,040	180 (160 – 200)		
P11	M/E/A	0,32	0,0026	0,0040	0,0050	0,0065	0,0080	0,010	0,013	0,016	0,024	0,026	0,032	0,040	185 (165 – 205)		
P12	M/E/A	0,32	0,0022	0,0032	0,0042	0,0055	0,0065	0,0085	0,011	0,013	0,018	0,019	0,022	0,024	110 (100 – 120)		
M1	E/M/A	0,32	0,0026	0,0040	0,0050	0,0065	0,0080	0,010	0,013	0,016	0,024	0,026	0,032	0,040	135 (110 – 160)		
M2	E/M/A	0,32	0,0026	0,0040	0,0050	0,0065	0,0080	0,010	0,013	0,016	0,024	0,026	0,032	0,040	110 (90 – 130)		
M3	E/M/A	0,32	0,0026	0,0040	0,0050	0,0065	0,0080	0,010	0,013	0,016	0,024	0,026	0,032	0,040	110 (90 – 130)		
M4	E/M/A	0,32	0,0026	0,0040	0,0050	0,0065	0,0080	0,010	0,013	0,016	0,024	0,026	0,032	0,036	80 (70 – 100)		
M5	E/M/A	0,32	0,0026	0,0040	0,0050	0,0065	0,0080	0,010	0,013	0,016	0,024	0,026	0,032	0,036	70 (55 – 80)		
N1	E/M/A	0,24	0,0026	0,0040	0,0050	0,0065	0,0080	0,010	0,013	0,016	0,024	0,026	0,032	0,040	400 (350 – 450)		
N2	E/M/A	0,26	0,0026	0,0040	0,0050	0,0065	0,0080	0,010	0,013	0,016	0,024	0,026	0,032	0,040	400 (350 – 450)		
N3	E/M/A	0,26	0,0026	0,0040	0,0050	0,0065	0,0080	0,010	0,013	0,016	0,024	0,026	0,032	0,040	265 (235 – 300)		
N11	E/M/A	0,24	0,0040	0,0060	0,0080	0,010	0,012	0,016	0,020	0,024	0,036	0,040	0,048	0,055	350 (300 – 400)		
S11	E/M/A	0,34	0,0026	0,0040	0,0050	0,0065	0,0080	0,010	0,013	0,016	0,024	0,026	0,032	0,040	180 (160 – 210)		
S12	E/M/A	0,34	0,0026	0,0040	0,0050	0,0065	0,0080	0,010	0,013	0,016	0,024	0,026	0,032	0,040	140 (120 – 160)		
S13	E/M/A	0,34	0,0026	0,0040	0,0050	0,0065	0,0080	0,010	0,013	0,016	0,024	0,026	0,032	0,036	110 (95 – 125)		
H3	M/A	0,10	0,0024	0,0036	0,0048	0,0060	0,0070	0,0095	0,012	0,014	0,022	0,024	0,030	0,036	80 (60 – 100)		
H5	M/A	0,20	0,0026	0,0040	0,0050	0,0065	0,0080	0,010	0,013	0,016	0,024	0,026	0,032	0,040	160 (140 – 180)		
H7	M/A	0,10	0,0024	0,0036	0,0048	0,0060	0,0070	0,0095	0,012	0,014	0,022	0,024	0,030	0,036	80 (60 – 100)		
H8	M/A	0,20	0,0024	0,0036	0,0048	0,0060	0,0070	0,0095	0,012	0,014	0,022	0,024	0,026	0,030	160 (140 – 180)		
H11	M/A	0,20	0,0026	0,0040	0,0050	0,0065	0,0080	0,010	0,013	0,016	0,024	0,026	0,032	0,040	205 (180 – 230)		
H12	M/A	0,20	0,0024	0,0036	0,0048	0,0060	0,0070	0,0095	0,012	0,014	0,022	0,024	0,026	0,030	190 (165 – 210)		
H21	M/A	0,20	0,0024	0,0036	0,0048	0,0060	0,0070	0,0095	0,012	0,014	0,022	0,024	0,026	0,030	160 (140 – 180)		
H31	M/A	0,20	0,0020	0,0030	0,0042	0,0050	0,0060	0,0080	0,010	0,012	0,017	0,018	0,020	0,022	120 (110 – 140)		
GR1	A	0,50	0,0020	0,0030	0,0040	0,0050	0,0060	0,0080	0,010	0,012	0,018	0,020	0,025	0,030	350 (300 – 400)		

Table based on LV1, please recalc based on length version chosen. See page(s) 411-418

SMG = Seco material group

Coolant = A=air D=dry E=emulsion M=mist spray

v_c = m/min

f_z = mm

a_p (mm)/DC (mm)= factor

a_e (mm)/DC (mm)= factor

All cutting data are target values

Cutting data – JMB542/JMB562 Copy milling roughing

SMG		a _g /DC	a _p /DC	f _z												v _c	
				0,2	0,3	0,4	0,5	0,6	0,8	1,0	1,2	1,8	2,0	2,5	3,0		
P1	M/E/A	0,050	0,60	0,0040	0,0060	0,0080	0,010	0,012	0,016	0,020	0,024	0,036	0,040	0,050	0,060	365 (325 — 405)	
P2	M/E/A	0,050	0,60	0,0040	0,0060	0,0080	0,010	0,012	0,016	0,020	0,024	0,036	0,040	0,050	0,060	355 (315 — 395)	
P3	M/E/A	0,050	0,60	0,0040	0,0060	0,0080	0,010	0,012	0,016	0,020	0,024	0,036	0,040	0,050	0,060	305 (270 — 340)	
P4	M/E/A	0,050	0,60	0,0040	0,0060	0,0080	0,010	0,012	0,016	0,020	0,024	0,036	0,040	0,050	0,060	270 (240 — 300)	
P5	M/E/A	0,050	0,60	0,0040	0,0060	0,0080	0,010	0,012	0,016	0,020	0,024	0,036	0,040	0,050	0,060	255 (230 — 285)	
P6	M/E/A	0,050	0,60	0,0040	0,0060	0,0080	0,010	0,012	0,016	0,020	0,024	0,036	0,040	0,050	0,060	290 (260 — 320)	
P7	M/E/A	0,050	0,60	0,0040	0,0060	0,0080	0,010	0,012	0,016	0,020	0,024	0,036	0,040	0,050	0,060	270 (240 — 300)	
P8	M/E/A	0,050	0,60	0,0040	0,0060	0,0080	0,010	0,012	0,016	0,020	0,024	0,036	0,040	0,050	0,060	255 (230 — 285)	
P11	M/E/A	0,050	0,60	0,0040	0,0060	0,0080	0,010	0,012	0,016	0,020	0,024	0,036	0,040	0,050	0,060	265 (235 — 290)	
P12	M/E/A	0,050	0,60	0,0032	0,0048	0,0065	0,0080	0,010	0,013	0,016	0,020	0,028	0,030	0,034	0,038	155 (140 — 175)	
M1	E/M/A	0,024	0,60	0,0040	0,0060	0,0080	0,010	0,012	0,016	0,020	0,024	0,036	0,040	0,050	0,060	215 (180 — 255)	
M2	E/M/A	0,024	0,60	0,0040	0,0060	0,0080	0,010	0,012	0,016	0,020	0,024	0,036	0,040	0,050	0,060	175 (145 — 205)	
M3	E/M/A	0,024	0,60	0,0040	0,0060	0,0080	0,010	0,012	0,016	0,020	0,024	0,036	0,040	0,050	0,060	175 (145 — 205)	
M4	E/M/A	0,024	0,60	0,0040	0,0060	0,0080	0,010	0,012	0,016	0,020	0,024	0,036	0,040	0,050	0,060	130 (110 — 155)	
M5	E/M/A	0,024	0,60	0,0040	0,0060	0,0080	0,010	0,012	0,016	0,020	0,024	0,036	0,040	0,050	0,060	110 (90 — 130)	
N1	E/M/A	0,10	0,75	0,0040	0,0060	0,0080	0,010	0,012	0,016	0,020	0,024	0,032	0,034	0,040	0,042	485 (425 — 545)	
N2	E/M/A	0,10	0,75	0,0040	0,0060	0,0080	0,010	0,012	0,016	0,020	0,024	0,034	0,036	0,040	0,044	485 (425 — 550)	
N3	E/M/A	0,10	0,75	0,0040	0,0060	0,0080	0,010	0,012	0,016	0,020	0,024	0,034	0,036	0,040	0,044	325 (285 — 365)	
N11	E/M/A	0,10	0,75	0,0050	0,0075	0,010	0,012	0,015	0,020	0,025	0,030	0,040	0,044	0,050	0,055	430 (370 — 490)	
S11	E/M/A	0,024	0,60	0,0040	0,0060	0,0080	0,010	0,012	0,016	0,020	0,024	0,036	0,040	0,050	0,060	290 (250 — 335)	
S12	E/M/A	0,024	0,60	0,0040	0,0060	0,0080	0,010	0,012	0,016	0,020	0,024	0,036	0,040	0,050	0,060	225 (195 — 260)	
S13	E/M/A	0,024	0,60	0,0040	0,0060	0,0080	0,010	0,012	0,016	0,020	0,024	0,036	0,040	0,050	0,060	175 (150 — 200)	
H3	M/A	0,050	0,30	0,0030	0,0044	0,0060	0,0075	0,0090	0,012	0,015	0,017	0,024	0,025	0,028	0,030	120 (90 — 145)	
H5	M/A	0,050	0,44	0,0040	0,0060	0,0080	0,010	0,012	0,016	0,020	0,024	0,036	0,040	0,046	0,050	235 (210 — 260)	
H7	M/A	0,050	0,30	0,0030	0,0044	0,0060	0,0075	0,0090	0,012	0,015	0,017	0,024	0,025	0,028	0,030	120 (90 — 150)	
H8	M/A	0,050	0,44	0,0032	0,0050	0,0065	0,0085	0,010	0,013	0,016	0,020	0,026	0,028	0,032	0,034	235 (205 — 265)	
H11	M/A	0,050	0,44	0,0040	0,0060	0,0080	0,010	0,012	0,016	0,020	0,024	0,036	0,040	0,046	0,050	300 (265 — 340)	
H12	M/A	0,050	0,44	0,0032	0,0050	0,0065	0,0085	0,010	0,013	0,016	0,020	0,026	0,028	0,032	0,034	275 (240 — 310)	
H21	M/A	0,050	0,44	0,0032	0,0050	0,0065	0,0085	0,010	0,013	0,016	0,020	0,026	0,028	0,032	0,034	235 (205 — 265)	
H31	M/A	0,050	0,44	0,0025	0,0036	0,0050	0,0060	0,0075	0,010	0,012	0,015	0,020	0,020	0,024	0,026	175 (155 — 200)	
GR1	A	0,50	0,50	0,0030	0,0044	0,0060	0,0075	0,0090	0,012	0,015	0,018	0,024	0,025	0,028	0,032	405 (350 — 460)	

Table based on LV1, please recalc based on length version chosen. See page(s) 411-418

SMG = Seco material group

Coolant = A=air D=dry E=emulsion M=mist spray

v_c = m/min

f_z = mm

a_p (mm)/DC (mm)= factor

a_g (mm)/DC (mm)= factor

All cutting data are target values

Cutting data – JMB563 Copy milling roughing

SMG		a _g /DC	a _p /DC	f _z							v _c
				1	1,2	1,5	2,0	2,5	3,0		
P1	M/E/A	0,050	0,11	0,018	0,020	0,025	0,030	0,034	0,038	370 (330 – 410)	
P2	M/E/A	0,050	0,11	0,018	0,022	0,025	0,030	0,034	0,038	360 (320 – 400)	
P3	M/E/A	0,050	0,11	0,017	0,020	0,024	0,028	0,032	0,036	310 (275 – 345)	
P4	M/E/A	0,050	0,11	0,017	0,020	0,024	0,028	0,032	0,034	275 (245 – 300)	
P5	M/E/A	0,050	0,11	0,016	0,019	0,022	0,028	0,032	0,034	260 (230 – 290)	
P6	M/E/A	0,050	0,11	0,016	0,019	0,022	0,028	0,030	0,034	290 (260 – 325)	
P7	M/E/A	0,050	0,11	0,016	0,019	0,022	0,028	0,030	0,034	275 (245 – 305)	
P8	M/E/A	0,050	0,11	0,017	0,020	0,024	0,028	0,032	0,036	260 (230 – 290)	
P11	M/E/A	0,050	0,11	0,016	0,019	0,022	0,028	0,030	0,034	265 (240 – 295)	
P12	M/E/A	0,050	0,11	0,0090	0,011	0,013	0,015	0,017	0,019	150 (135 – 170)	
M1	E/M/A	0,024	0,11	0,019	0,022	0,026	0,032	0,036	0,040	215 (180 – 255)	
M2	E/M/A	0,024	0,11	0,017	0,020	0,024	0,028	0,032	0,036	175 (145 – 205)	
M3	E/M/A	0,024	0,11	0,017	0,020	0,024	0,028	0,032	0,036	175 (145 – 205)	
M4	E/M/A	0,024	0,11	0,015	0,018	0,020	0,025	0,028	0,032	130 (105 – 150)	
M5	E/M/A	0,024	0,11	0,015	0,018	0,020	0,025	0,028	0,032	105 (90 – 125)	
N1	E/M/A	0,10	0,50	0,018	0,020	0,025	0,030	0,034	0,038	500 (440 – 565)	
N2	E/M/A	0,10	0,50	0,018	0,020	0,025	0,030	0,034	0,038	500 (440 – 565)	
N3	E/M/A	0,10	0,50	0,018	0,020	0,025	0,030	0,034	0,038	335 (295 – 375)	
N11	E/M/A	0,10	0,50	0,022	0,026	0,032	0,038	0,042	0,046	440 (380 – 500)	
S11	E/M/A	0,024	0,26	0,020	0,024	0,030	0,038	0,042	0,046	300 (260 – 340)	
S12	E/M/A	0,024	0,26	0,020	0,024	0,030	0,038	0,042	0,046	230 (200 – 265)	
S13	E/M/A	0,024	0,26	0,019	0,022	0,028	0,032	0,038	0,040	180 (155 – 205)	
H3	M/A	0,024	0,028	0,010	0,012	0,014	0,017	0,020	0,022	115 (90 – 140)	
H5	M/A	0,050	0,070	0,014	0,016	0,019	0,024	0,026	0,030	225 (200 – 255)	
H7	M/A	0,024	0,028	0,010	0,012	0,014	0,017	0,020	0,022	115 (85 – 140)	
H8	M/A	0,050	0,070	0,0095	0,011	0,014	0,016	0,019	0,020	220 (195 – 245)	
H11	M/A	0,050	0,070	0,014	0,016	0,019	0,024	0,026	0,030	290 (255 – 325)	
H12	M/A	0,050	0,070	0,0095	0,011	0,014	0,016	0,019	0,020	255 (225 – 290)	
H21	M/A	0,050	0,070	0,0095	0,011	0,014	0,016	0,019	0,020	220 (190 – 250)	
H31	M/A	0,050	0,070	0,0075	0,0085	0,010	0,012	0,014	0,015	160 (140 – 180)	
GR1	A	0,50	0,24	0,015	0,018	0,022	0,026	0,030	0,032	385 (330 – 440)	

Table based on LV1, please recalc based on length version chosen. See page(s) 411-418

SMG = Seco material group

Coolant = A=air D=dry E=emulsion M=mist spray

v_c = m/min

f_z = mm

a_p (mm)/DC (mm)= factor

a_g (mm)/DC (mm)= factor















All cutting data are target values



Name		JHP993	JHP951	JH142	JH970
Page(s)		156-158	159-161	164-166, 324-326	110-111, 168-169
Family name		HPM	HPM	HSM/TORNADO	HSM/TORNADO
Type of mill					
Shank	Cylindrical	■	■	■	■
	Weldon	■	■		
Number of Flutes		3-6	3-5	2-4-5-6	2
ICC					
Diameter range	Metric	4-25	3-25	2-12	2-16
	Inch				
Length availability					
		2,3	2	2,3,6	1,2,3
Operation					
SMG					
P1		●	●	●	●
P2		●	●	●	●
P3		●	●	●	●
P4		●	●	●	●
P5		●	●	●	●
P6		●	●	●	●
P7		●	●	●	●
P8		●	●	●	●
P11-12		○	○	●	○
K1		●	●	●	
K2		●	●	●	
K3		●	●	●	
K4		●	●	●	
K5		●	●	●	
K6		●	●	●	
K7		●	●	●	

■ Stock standard □ Weldon available, delivery time is 3 days.

● Preferred choice ○ Alternative choice

				
				
Name		JH112	JH150	JH160
Page(s)		170-172, 328-330	170, 327	172, 329
Family name		HSM/TORNADO	HSM/TORNADO	HSM/TORNADO
Type of mill				
Shank	Cylindrical	<input checked="" type="checkbox"/>	<input checked="" type="checkbox"/>	<input checked="" type="checkbox"/>
	Weldon	<input type="checkbox"/>	<input type="checkbox"/>	<input type="checkbox"/>
Number of Flutes		2	4	4
ICC				
Diameter range	Metric	2-12	6-12	3-12
	Inch			
Length availability				
		1,2,3,4,5,6	2	2
Operation				
SMG				
P1				●
P2				●
P3				●
P4				●
P5				●
P6				●
P7				●
P8				●
P11-12				○
K1		●	●	
K2		●	●	
K3		●	●	
K4		●	●	
K5		●	●	
K6		●	●	
K7		●	●	

Stock standard Weldon available, delivery time is 3 days.

● Preferred choice ○ Alternative choice

JHP993 - High performance - Steel - Square - 3-6 Flutes - Cylindrical - Chamfer

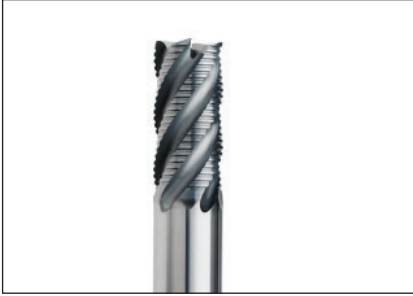

Tolerances:
 DMM=h5
 DC= -0,02/-0,1 mm
 CHW= ±0,05 mm
 Regrind possible if DC is ≥Ø6

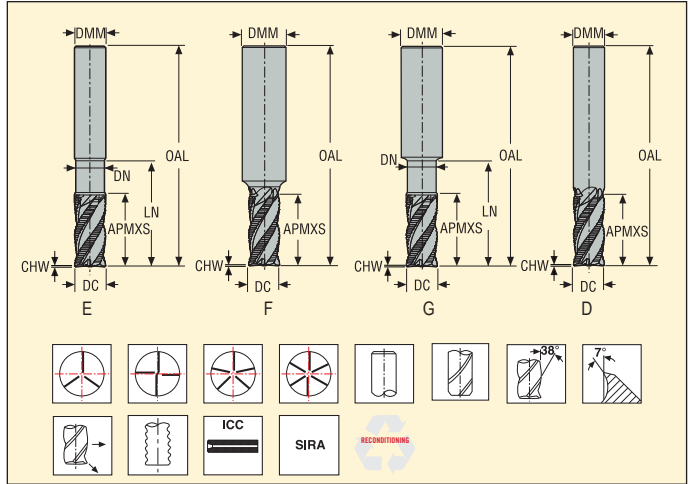

Ordering and Product No.	Designation	Length index	Tool shape	ICC	Dimensions in mm							PCEDC	Cylindrical
					DC	DMM	APMXS	OAL	LN	DN	CHW		
02826806	JHP993040F2C.0Z3-SIRA	2	F		4,0	6	10	50	13	4,0	0,15	3	■
02826808	JHP993050F2C.0Z4-SIRA	2	F		5,0	6	12	55	15	5,0	0,15	4	■
02826809	JHP993060D2C.0Z4-SIRA	2	D		6,0	6	14	55	-	-	0,2	4	■
02826811	JHP993075F2C.0Z4-SIRA	2	F		7,5	8	17	60	-	7,5	0,2	4	■
02826814	JHP993080D2C.0Z4A-SIRA	2	D	■	8,0	8	18	60	-	-	0,2	4	■
02826812	JHP993080D2C.0Z4-SIRA	2	D		8,0	8	18	60	-	-	0,2	4	■
02826816	JHP993095F2C.0Z4-SIRA	2	F		9,5	10	20	70	-	9,5	0,2	4	■
02826818	JHP993100D2C.0Z4A-SIRA	2	D	■	10,0	10	22	70	-	-	0,2	4	■
02826817	JHP993100D2C.0Z4-SIRA	2	D		10,0	10	22	70	-	-	0,2	4	■
02826820	JHP993115F2C.0Z4-SIRA	2	F		11,5	12	25	80	-	11,5	0,2	4	■
02826822	JHP993120D2C.0Z4A-SIRA	2	D	■	12,0	12	26	80	-	-	0,2	4	■
02826821	JHP993120D2C.0Z4-SIRA	2	D		12,0	12	26	80	-	-	0,2	4	■
02826824	JHP993140D2C.0Z4-SIRA	2	D		14,0	14	30	80	-	-	0,3	4	■
02856501	JHP993160D2C.0Z4A-SIRA	2	D	■	16,0	16	34	90	-	-	0,3	4	■
02856499	JHP993160D2C.0Z4-SIRA	2	D		16,0	16	34	90	-	-	0,3	4	■
02856506	JHP993200D2C.0Z4A-SIRA	2	D	■	20,0	20	42	100	-	-	0,5	4	■
02856505	JHP993200D2C.0Z4-SIRA	2	D		20,0	20	42	100	-	-	0,5	4	■
02856510	JHP993250D2C.0Z4A-SIRA	2	D	■	25,0	25	52	125	-	-	0,5	4	■
02826825	JHP993160D2C.0Z5-SIRA	2	D		16,0	16	34	90	-	-	0,3	5	■
02826829	JHP993200D2C.0Z5A-SIRA	2	D	■	20,0	20	42	100	-	-	0,5	5	■
02826828	JHP993200D2C.0Z5-SIRA	2	D		20,0	20	42	100	-	-	0,5	5	■
02826807	JHP993040G3C.0Z3-SIRA	3	G		4,0	6	10	55	15	3,7	0,15	3	■
02826810	JHP993060E3C.0Z4-SIRA	3	E		6,0	6	14	65	24	5,6	0,2	4	■
02826815	JHP993080E3C.0Z4-SIRA	3	E		8,0	8	18	70	32	7,4	0,2	4	■
02826819	JHP993100E3C.0Z4-SIRA	3	E		10,0	10	22	85	40	9,4	0,2	4	■
02826823	JHP993120E3C.0Z4-SIRA	3	E		12,0	12	26	100	50	11,4	0,2	4	■
02856502	JHP993160E3C.0Z4-SIRA	3	E		16,0	16	34	110	60	15,4	0,3	4	■
02856507	JHP993200E3C.0Z4-SIRA	3	E		20,0	20	42	125	70	19,2	0,5	4	■

SIRA = SIRON-A, ICC = Internal Coolant Channel

■ Stock standard. Subject to change refer to current price- and stock-list

JHP993 – High performance – Steel – Square – 3-6 Flutes – Weldon – Chamfer



Tolerances:

DMM=h5

DC=-0,02/-0,1 mm

CHW= ±0,05 mm

Regrind possible if DC is ≥Ø6

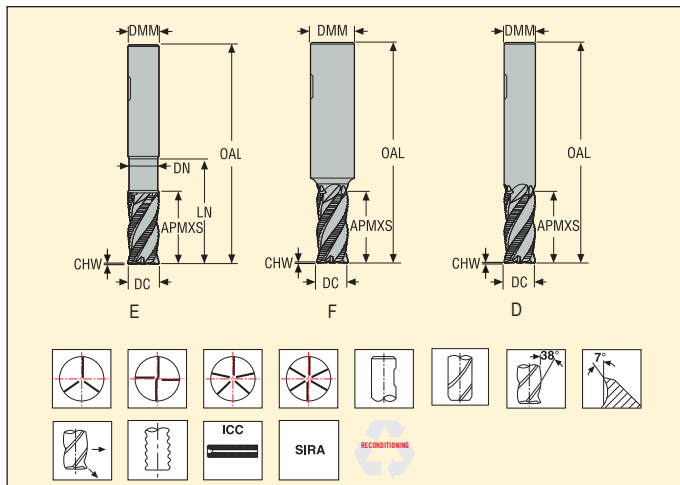

Ordering and Product No.	Designation	Length index	Tool shape	ICC	Dimensions in mm							PCEDC	Weldon
					DC	DMM	APMXS	OAL	LN	DN	CHW		
02828150	JHP993040F2C.3Z3-SIRA	2	F		4,0	6	10	50	12,56	4,0	0,15	3	■
02828152	JHP993050F2C.3Z4-SIRA	2	F		5,0	6	12	55	14,75	5,0	0,15	4	■
02828153	JHP993060D2C.3Z4-SIRA	2	D		6,0	6	14	55	-	-	0,2	4	■
02828155	JHP993075F2C.3Z4-SIRA	2	F		7,5	8	17	60	-	7,5	0,2	4	■
02828246	JHP993080D2C.3Z4A-SIRA	2	D	■	8,0	8	16	60	-	-	0,2	4	□
02828156	JHP993080D2C.3Z4-SIRA	2	D		8,0	8	18	60	-	-	0,2	4	■
02828158	JHP993095F2C.3Z4-SIRA	2	F		9,5	10	20	70	-	9,5	0,2	4	■
02828247	JHP993100D2C.3Z4A-SIRA	2	D	■	10,0	10	20	70	-	-	0,2	4	□
02828159	JHP993100D2C.3Z4-SIRA	2	D		10,0	10	22	70	-	-	0,2	4	■
02828248	JHP993120D2C.3Z4A-SIRA	2	D	■	12,0	12	26	80	-	-	0,2	4	□
02828162	JHP993120D2C.3Z4-SIRA	2	D		12,0	12	26	80	-	-	0,2	4	■
02828164	JHP993140D2C.3Z4-SIRA	2	D		14,0	14	30	80	-	-	0,3	4	■
02856512	JHP993160D2C.3Z4A-SIRA	2	D	■	16,0	16	34	90	-	-	0,3	4	□
02856500	JHP993160D2C.3Z4-SIRA	2	D		16,0	16	34	90	-	-	0,3	4	■
02856513	JHP993200D2C.3Z4A-SIRA	2	D	■	20,0	20	42	100	-	-	0,5	4	■
02856504	JHP993200D2C.3Z4-SIRA	2	D		20,0	20	42	100	-	-	0,5	4	■
02856514	JHP993250D2C.3Z4A-SIRA	2	D	■	25,0	25	52	125	-	-	0,5	4	□
02856509	JHP993250D2C.3Z4-SIRA	2	D		25,0	25	52	125	-	-	0,5	4	■
02828165	JHP993160D2C.3Z5-SIRA	2	D		16,0	16	34	90	-	-	0,3	5	■
02828250	JHP993200D2C.3Z5A-SIRA	2	D	■	20,0	20	42	100	-	-	0,5	5	□
02828167	JHP993200D2C.3Z5-SIRA	2	D		20,0	20	42	100	-	-	0,5	5	■
02828154	JHP993060E3C.3Z4-SIRA	3	E		6,0	6	14	65	24,0	5,6	0,2	4	■
02828157	JHP993080E3C.3Z4-SIRA	3	E		8,0	8	18	70	32,0	7,4	0,2	4	■
02828160	JHP993100E3C.3Z4-SIRA	3	E		10,0	10	22	85	40,0	9,4	0,2	4	■
02828163	JHP993120E3C.3Z4-SIRA	3	E		12,0	12	26	100	50,0	11,4	0,2	4	■
02856503	JHP993160E3C.3Z4-SIRA	3	E		16,0	16	34	110	60,0	15,4	0,3	4	■
02856508	JHP993200E3C.3Z4-SIRA	3	E		20,0	20	42	125	70,0	19,2	0,5	4	■
02856511	JHP993250E3C.3Z4-SIRA	3	E		25,0	25	52	150	90,0	24,0	0,5	4	■
02828168	JHP993200E3C.3Z5-SIRA	3	E		20,0	20	42	125	70,0	19,2	0,5	5	■

SIRA = SIRON-A, ICC = Internal Coolant Channel

■ Stock standard. Subject to change refer to current price- and stock-list □ Weldon available, delivery time is 3 days.

Cutting data – JHP993 Slot milling PCEDC=3 and PCEDC=4

SMG		a_p/DC	f_z											v_c
			4	5	6	8	10	12	14	16	20	25		
P1	E/M/A	1,5	0,032	0,040	0,048	0,065	0,080	0,095	0,11	—	0,16	0,20	200 (170 – 230)	
P2	E/M/A	1,5	0,032	0,040	0,048	0,065	0,080	0,095	0,11	—	0,16	0,20	195 (165 – 220)	
P3	E/M/A	1,5	0,032	0,040	0,048	0,065	0,080	0,095	0,11	—	0,16	0,20	165 (145 – 190)	
P4	E/M/A	1,5	0,032	0,040	0,048	0,065	0,080	0,095	0,11	0,13	0,16	0,20	145 (125 – 170)	
P5	E/M/A	1,5	0,032	0,040	0,048	0,065	0,080	0,095	0,11	—	0,16	0,19	140 (120 – 160)	
P6	E/M/A	1,5	0,032	0,040	0,048	0,065	0,080	0,095	0,11	0,13	0,16	0,19	160 (135 – 180)	
P7	E/M/A	1,5	0,032	0,040	0,048	0,065	0,080	0,095	0,11	—	0,16	0,19	150 (130 – 170)	
P8	E/M/A	1,5	0,032	0,040	0,048	0,065	0,080	0,095	—	0,13	0,16	0,20	140 (120 – 160)	
P11	E/M/A	1,5	0,032	0,040	0,048	0,065	0,080	0,095	0,11	—	0,16	0,19	145 (125 – 165)	
P12	E/M/A	1,2	0,024	0,030	0,036	0,048	0,060	0,070	0,080	—	0,10	0,12	90 (80 – 105)	
K1	E/M/A	1,5	0,032	0,040	0,048	0,065	0,080	0,095	0,11	—	0,16	0,20	195 (170 – 225)	
K2	E/M/A	1,5	0,032	0,040	0,048	0,065	0,080	0,095	0,11	—	0,16	0,19	170 (145 – 195)	
K3	E/M/A	1,5	0,032	0,040	0,048	0,065	0,080	0,095	0,11	—	0,16	0,19	145 (125 – 165)	
K4	E/M/A	1,5	0,032	0,040	0,048	0,065	0,080	0,095	0,11	—	0,16	0,19	135 (120 – 155)	
K5	E/M/A	1,5	0,032	0,040	0,048	0,065	0,080	0,095	0,11	—	0,15	0,17	80 (70 – 95)	
K6	E/M/A	1,5	0,032	0,040	0,048	0,065	0,080	0,095	0,11	—	0,16	0,19	120 (105 – 140)	
K7	E/M/A	1,5	0,032	0,040	0,048	0,065	0,080	0,095	0,11	—	0,15	0,17	105 (90 – 120)	

Cutting data – JHP993 Side milling PCEDC=4,5,6

SMG		a_p/DC	a_p/DC	f_z											v_c
				4	5	6	8	10	12	14	16	20	25		
P1	E/M/A	0,40	1,7	0,044	0,055	0,065	0,090	0,11	0,13	0,15	0,16	0,19	0,22	230 (200 – 265)	
P2	E/M/A	0,40	1,7	0,044	0,055	0,065	0,090	0,11	0,13	0,15	0,17	0,19	0,22	225 (195 – 255)	
P3	E/M/A	0,40	1,7	0,042	0,055	0,065	0,085	0,11	0,13	0,14	0,16	0,18	0,20	195 (165 – 220)	
P4	E/M/A	0,40	1,7	0,042	0,050	0,060	0,085	0,10	0,12	0,14	0,15	0,18	0,20	175 (150 – 200)	
P5	E/M/A	0,40	1,7	0,040	0,050	0,060	0,080	0,10	0,12	0,14	0,15	0,17	0,20	165 (145 – 190)	
P6	E/M/A	0,40	1,7	0,040	0,050	0,060	0,080	0,10	0,12	0,14	0,15	0,17	0,19	185 (160 – 215)	
P7	E/M/A	0,40	1,7	0,040	0,050	0,060	0,080	0,10	0,12	0,14	0,15	0,17	0,19	175 (150 – 200)	
P8	E/M/A	0,40	1,7	0,042	0,055	0,065	0,085	0,11	0,13	0,14	0,16	0,18	0,20	165 (140 – 185)	
P11	E/M/A	0,40	1,7	0,040	0,050	0,060	0,080	0,10	0,12	0,14	0,15	0,17	0,19	170 (145 – 195)	
P12	E/M/A	0,40	1,4	0,024	0,030	0,036	0,050	0,060	0,075	0,080	0,090	0,10	0,12	115 (100 – 130)	
K1	E/M/A	0,40	1,7	0,044	0,055	0,065	0,090	0,11	0,13	0,15	0,17	0,19	0,22	225 (195 – 260)	
K2	E/M/A	0,40	1,7	0,040	0,050	0,060	0,080	0,10	0,12	0,14	0,15	0,17	0,20	200 (175 – 230)	
K3	E/M/A	0,40	1,7	0,040	0,050	0,060	0,080	0,10	0,12	0,14	0,15	0,17	0,20	170 (145 – 195)	
K4	E/M/A	0,40	1,7	0,040	0,050	0,060	0,080	0,10	0,12	0,14	0,15	0,17	0,20	165 (140 – 185)	
K5	E/M/A	0,40	1,7	0,036	0,046	0,055	0,075	0,090	0,11	0,12	0,14	0,16	0,18	100 (85 – 115)	
K6	E/M/A	0,40	1,7	0,040	0,050	0,060	0,080	0,10	0,12	0,14	0,15	0,17	0,20	145 (125 – 165)	
K7	E/M/A	0,40	1,7	0,036	0,046	0,055	0,075	0,090	0,11	0,12	0,14	0,16	0,18	130 (110 – 145)	

For cutting data recalculations, see page 411-418.

SMG = Seco material group

Coolant = A=air D=dry E=emulsion M=mist spray

v_c = m/min

f_z = mm

a_p (mm)/DC (mm)= factor

a_e (mm)/DC (mm)= factor

All cutting data are target values

JHP951 – High performance – Square – Steel – 3-5 Flutes – Cylindrical – Corner radius or chamfer



Tolerances:
 DMM=h5
 DC=e7
 RE= ±0,02 mm
 Regrind possible if DC is ≥Ø6

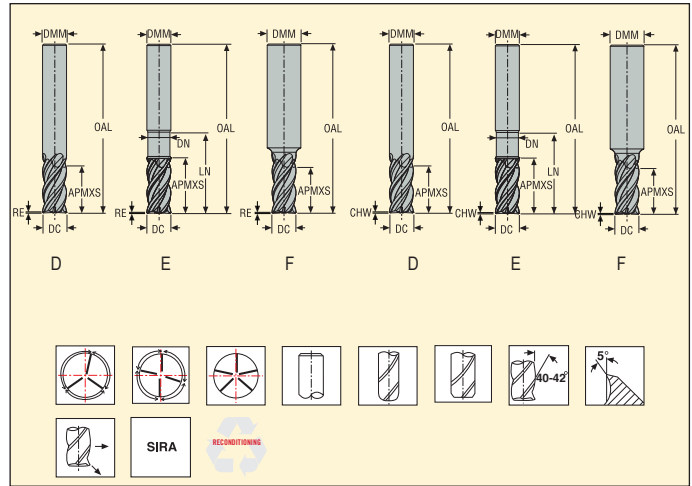

Ordering and Product No.	Designation	Length index	Tool shape	Dimensions in mm								PCEDC	Cylindrical
				DC	DMM	APMXS	OAL	LN	DN	CHW	RE		
02828192	JHP951030F2C.0Z3-SIRA	2	F	3,0	6	8	50	10	3,0	0,1	-	3	■
02828191	JHP951030F2R020.0Z3-SIRA	2	F	3,0	6	8	50	10	3,0	-	0,2	3	■
02828190	JHP951030F2R050.0Z3-SIRA	2	F	3,0	6	8	50	10	3,0	-	0,5	3	■
02828197	JHP951040F2C.0Z4-SIRA	2	F	4,0	6	10	55	13	4,0	0,15	-	4	■
02828194	JHP951040F2R020.0Z4-SIRA	2	F	4,0	6	10	55	13	4,0	-	0,2	4	■
02828195	JHP951040F2R050.0Z4-SIRA	2	F	4,0	6	10	55	13	4,0	-	0,5	4	■
02828201	JHP951050F2C.0Z4-SIRA	2	F	5,0	6	12	55	15	5,0	0,2	-	4	■
02828199	JHP951050F2R020.0Z4-SIRA	2	F	5,0	6	12	55	15	5,0	-	0,2	4	■
02828198	JHP951050F2R050.0Z4-SIRA	2	F	5,0	6	12	55	15	5,0	-	0,5	4	■
02828205	JHP951060D2C.0Z4-SIRA	2	D	6,0	6	14	55	-	-	0,2	-	4	■
02828203	JHP951060D2R020.0Z4-SIRA	2	D	6,0	6	14	55	-	-	-	0,2	4	■
02828202	JHP951060D2R050.0Z4-SIRA	2	D	6,0	6	14	55	-	-	-	0,5	4	■
02828212	JHP951080D2C.0Z4-SIRA	2	D	8,0	8	18	60	-	-	0,3	-	4	■
02828209	JHP951080D2R020.0Z4-SIRA	2	D	8,0	8	18	60	-	-	-	0,2	4	■
02828207	JHP951080D2R050.0Z4-SIRA	2	D	8,0	8	18	60	-	-	-	0,5	4	■
02828208	JHP951080D2R100.0Z4-SIRA	2	D	8,0	8	18	60	-	-	-	1,0	4	■
02828218	JHP951100E2C.0Z4-SIRA	2	E	10,0	10	22	70	28	9,4	0,3	-	4	■
02828216	JHP951100E2R050.0Z4-SIRA	2	E	10,0	10	22	70	28	9,4	-	0,5	4	■
02828214	JHP951100E2R100.0Z4-SIRA	2	E	10,0	10	22	70	28	9,4	-	1,0	4	■
02828226	JHP951120E2C.0Z4-SIRA	2	E	12,0	12	26	80	33	11,4	0,4	-	4	■
02828224	JHP951120E2R050.0Z4-SIRA	2	E	12,0	12	26	80	33	11,4	-	0,5	4	■
02828222	JHP951120E2R100.0Z4-SIRA	2	E	12,0	12	26	80	33	11,4	-	1,0	4	■
02927873	JHP951160E2C.0Z4-SIRA	2	E	16,0	16	34	90	40	15,0	0,5	-	4	■
02927875	JHP951160E2R050.0Z4-SIRA	2	E	16,0	16	34	90	40	15,0	-	0,5	4	■
02927876	JHP951160E2R100.0Z4-SIRA	2	E	16,0	16	34	90	40	15,0	-	1,0	4	■
02828232	JHP951160E2C.0Z5-SIRA	2	E	16,0	16	34	90	40	15,4	0,5	-	5	■
02828230	JHP951160E2R050.0Z5-SIRA	2	E	16,0	16	34	90	40	15,4	-	0,5	5	■
02828231	JHP951160E2R100.0Z5-SIRA	2	E	16,0	16	34	90	40	15,4	-	1,0	5	■

■ Stock standard. Subject to change refer to current price- and stock-list

JHP951 – High performance – Square – Steel – 3-5 Flutes – Weldon – Corner radius or chamfer



Tolerances:
 DMM=h5
 DC=e7
 RE= ±0,02 mm
 Regrind possible if DC is ≥Ø6

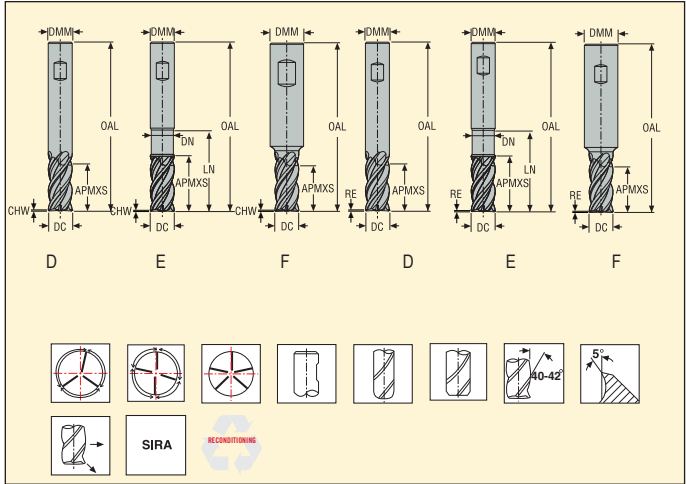

Ordering and Product No.	Designation	Length index	Tool shape	Dimensions in mm							RE	PCEDC	Weldon
				DC	DMM	APMXS	OAL	LN	DN	CHW			
02828193	JHP951030F2C.3Z3-SIRA	2	F	3,0	6	8	50	10	3,0	0,1	-	3	■
02828260	JHP951030F2R020.3Z3-SIRA	2	F	3,0	6	8	50	10	3,0	-	0,2	3	■
02828259	JHP951030F2R050.3Z3-SIRA	2	F	3,0	6	8	50	10	3,0	-	0,5	3	□
02828196	JHP951040F2C.3Z4-SIRA	2	F	4,0	6	10	55	13	4,0	0,15	-	4	■
02828261	JHP951040F2R020.3Z4-SIRA	2	F	4,0	6	10	55	13	4,0	-	0,2	4	□
02828262	JHP951040F2R050.3Z4-SIRA	2	F	4,0	6	10	55	13	4,0	-	0,5	4	□
02828200	JHP951050F2C.3Z4-SIRA	2	F	5,0	6	12	55	15	5,0	0,2	-	4	■
02828264	JHP951050F2R020.3Z4-SIRA	2	F	5,0	6	12	55	15	5,0	-	0,2	4	□
02828263	JHP951050F2R050.3Z4-SIRA	2	F	5,0	6	12	55	15	5,0	-	0,5	4	□
02828206	JHP951060D2C.3Z4-SIRA	2	D	6,0	6	14	55	-	-	0,2	-	4	■
02828266	JHP951060D2R020.3Z4-SIRA	2	D	6,0	6	14	55	-	-	-	0,2	4	□
02828265	JHP951060D2R050.3Z4-SIRA	2	D	6,0	6	14	55	-	-	-	0,5	4	□
02828210	JHP951080D2C.3Z4-SIRA	2	D	8,0	8	18	60	-	-	0,3	-	4	■
02828269	JHP951080D2R020.3Z4-SIRA	2	D	8,0	8	18	60	-	-	-	0,2	4	□
02828267	JHP951080D2R050.3Z4-SIRA	2	D	8,0	8	18	60	-	-	-	0,5	4	■
02828268	JHP951080D2R100.3Z4-SIRA	2	D	8,0	8	18	60	-	-	-	1,0	4	□
02828220	JHP951100E2C.3Z4-SIRA	2	E	10,0	10	22	70	28	9,4	0,3	-	4	■
02828271	JHP951100E2R050.3Z4-SIRA	2	E	10,0	10	22	70	28	9,4	-	0,5	4	□
02828270	JHP951100E2R100.3Z4-SIRA	2	E	10,0	10	22	70	28	9,4	-	1,0	4	□
02828228	JHP951120E2C.3Z4-SIRA	2	E	12,0	12	26	80	33	11,4	0,4	-	4	■
02828273	JHP951120E2R050.3Z4-SIRA	2	E	12,0	12	26	80	33	11,4	-	0,5	4	□
02828272	JHP951120E2R100.3Z4-SIRA	2	E	12,0	12	26	80	33	11,4	-	1,0	4	□
02927874	JHP951160E2C.3Z4-SIRA	2	E	16,0	16	34	90	40	15,0	0,5	-	4	■
02927879	JHP951160E2R050.3Z4-SIRA	2	E	16,0	16	34	90	40	15,0	-	0,5	4	□
02927880	JHP951160E2R100.3Z4-SIRA	2	E	16,0	16	34	90	40	15,0	-	1,0	4	□
02927877	JHP951200E2R050.3Z4-SIRA	2	E	20,0	20	42	100	48	19,0	-	0,5	4	■
02927878	JHP951200E2R100.3Z4-SIRA	2	E	20,0	20	42	100	48	19,0	-	1,0	4	■
02828233	JHP951160E2C.3Z5-SIRA	2	E	16,0	16	34	90	40	15,4	0,5	-	5	■
02828275	JHP951160E2R050.3Z5-SIRA	2	E	16,0	16	34	90	40	15,4	-	0,5	5	□
02828276	JHP951160E2R100.3Z5-SIRA	2	E	16,0	16	34	90	40	15,4	-	1,0	5	□
02828235	JHP951200E2R050.3Z5-SIRA	2	E	20,0	20	42	100	48	19,4	-	0,5	5	■
02828234	JHP951200E2R100.3Z5-SIRA	2	E	20,0	20	42	100	48	19,4	-	1,0	5	■
02828237	JHP951250E2R050.3Z5-SIRA	2	E	25,0	25	52	125	65	24,4	-	0,5	5	■
02828236	JHP951250E2R100.3Z5-SIRA	2	E	25,0	25	52	125	65	24,4	-	1,0	5	■

■ Stock standard. Subject to change refer to current price- and stock-list □ Weldon available, delivery time is 3 days.

Cutting data - JHP951 Slot milling

SMG		a _p /DC	f _z										v _c
			3	4	5	6	8	10	12	16	20	25	
P1	E/M/A	1,5	0,024	0,032	0,040	0,048	0,065	0,080	0,095	0,13	0,16	0,20	160 (140 — 180)
P2	E/M/A	1,5	0,024	0,032	0,040	0,048	0,065	0,080	0,095	0,13	0,16	0,20	155 (135 — 175)
P3	E/M/A	1,5	0,024	0,032	0,040	0,048	0,065	0,080	0,095	0,13	0,16	0,20	165 (145 — 190)
P4	E/M/A	1,5	0,024	0,032	0,040	0,048	0,065	0,080	0,095	0,13	0,16	0,20	145 (125 — 170)
P5	E/M/A	1,5	0,024	0,032	0,040	0,048	0,065	0,080	0,095	0,13	0,16	0,19	140 (120 — 160)
P6	E/M/A	1,5	0,024	0,032	0,040	0,048	0,065	0,080	0,095	0,13	0,16	0,19	125 (105 — 145)
P7	E/M/A	1,5	0,024	0,032	0,040	0,048	0,065	0,080	0,095	0,13	0,16	0,19	150 (125 — 170)
P8	E/M/A	1,5	0,024	0,032	0,040	0,048	0,065	0,080	0,095	0,13	0,16	0,20	140 (120 — 160)
P11	E/M/A	1,5	0,024	0,032	0,040	0,048	0,065	0,080	0,095	0,13	0,16	0,19	145 (125 — 165)
P12	E/M/A	1,2	0,018	0,024	0,030	0,036	0,048	0,060	0,070	0,090	0,10	0,12	90 (80 — 105)
K1	E/M/A	1,5	0,024	0,032	0,040	0,048	0,065	0,080	0,095	0,13	0,16	0,20	195 (170 — 225)
K2	E/M/A	1,5	0,024	0,032	0,040	0,048	0,065	0,080	0,095	0,13	0,16	0,19	170 (145 — 195)
K3	E/M/A	1,5	0,024	0,032	0,040	0,048	0,065	0,080	0,095	0,13	0,16	0,19	145 (125 — 165)
K4	E/M/A	1,5	0,024	0,032	0,040	0,048	0,065	0,080	0,095	0,13	0,16	0,19	135 (115 — 155)
K5	E/M/A	1,5	0,024	0,032	0,040	0,048	0,065	0,080	0,095	0,13	0,15	0,17	80 (70 — 95)
K6	E/M/A	1,5	0,024	0,032	0,040	0,048	0,065	0,080	0,095	0,13	0,16	0,19	120 (105 — 140)
K7	E/M/A	1,5	0,024	0,032	0,040	0,048	0,065	0,080	0,095	0,13	0,15	0,17	105 (90 — 120)

Cutting data - JHP951 Side milling

SMG		a _p /DC	a _p /DC	f _z										v _c
				3	4	5	6	8	10	12	16	20	25	
P1	E/M/A	0,40	1,7	0,034	0,044	0,055	0,065	0,090	0,11	0,13	0,16	0,19	0,22	185 (165 — 210)
P2	E/M/A	0,40	1,7	0,034	0,044	0,055	0,065	0,090	0,11	0,13	0,17	0,19	0,22	180 (160 — 205)
P3	E/M/A	0,40	1,7	0,032	0,042	0,055	0,065	0,085	0,11	0,13	0,16	0,18	0,20	195 (165 — 220)
P4	E/M/A	0,40	1,7	0,032	0,042	0,050	0,060	0,085	0,10	0,12	0,15	0,18	0,20	175 (150 — 200)
P5	E/M/A	0,40	1,7	0,030	0,040	0,050	0,060	0,080	0,10	0,12	0,15	0,17	0,20	165 (145 — 190)
P6	E/M/A	0,40	1,7	0,030	0,040	0,050	0,060	0,080	0,10	0,12	0,15	0,17	0,19	150 (125 — 175)
P7	E/M/A	0,40	1,7	0,030	0,040	0,050	0,060	0,080	0,10	0,12	0,15	0,17	0,19	175 (150 — 200)
P8	E/M/A	0,40	1,7	0,032	0,042	0,055	0,065	0,085	0,11	0,13	0,16	0,18	0,20	160 (140 — 185)
P11	E/M/A	0,40	1,7	0,030	0,040	0,050	0,060	0,080	0,10	0,12	0,15	0,17	0,19	170 (145 — 195)
P12	E/M/A	0,40	1,4	0,018	0,024	0,030	0,036	0,050	0,060	0,075	0,090	0,10	0,12	115 (100 — 130)
K1	E/M/A	0,40	1,7	0,034	0,044	0,055	0,065	0,090	0,11	0,13	0,17	0,19	0,22	225 (195 — 260)
K2	E/M/A	0,40	1,7	0,030	0,040	0,050	0,060	0,080	0,10	0,12	0,15	0,17	0,20	200 (175 — 230)
K3	E/M/A	0,40	1,7	0,030	0,040	0,050	0,060	0,080	0,10	0,12	0,15	0,17	0,20	170 (145 — 195)
K4	E/M/A	0,40	1,7	0,030	0,040	0,050	0,060	0,080	0,10	0,12	0,15	0,17	0,20	165 (140 — 185)
K5	E/M/A	0,40	1,7	0,028	0,036	0,046	0,055	0,075	0,090	0,11	0,14	0,16	0,18	100 (85 — 115)
K6	E/M/A	0,40	1,7	0,030	0,040	0,050	0,060	0,080	0,10	0,12	0,15	0,17	0,20	145 (125 — 165)
K7	E/M/A	0,40	1,7	0,028	0,036	0,046	0,055	0,075	0,090	0,11	0,14	0,16	0,18	125 (110 — 145)

For cutting data recalculations, see page 411-418.

SMG = Seco material group

Coolant = A=air D=dry E=emulsion M=mist spray

v_c = m/min

f_z = mm

a_p (mm)/DC (mm) = factor

a_e (mm)/DC (mm) = factor

All cutting data are target values

JH142 – High speed – High precision – Torical – Hardened steel – 2-6 Flutes – Cylindrical – Corner radius



Tolerances:
 Run-out= <0,005 mm
 DMM= h5
 DC= 0-0.01 mm
 RE= ±0,005 mm
 Regrind possible if DC is ≥Ø6

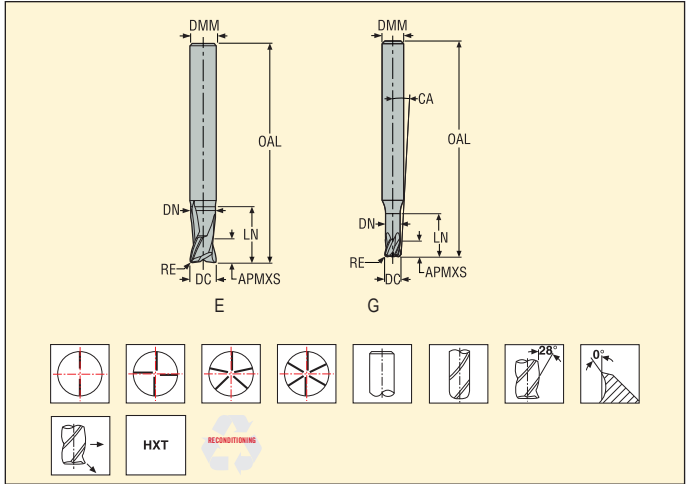

Ordering and Product No.	Designation	Length index	Tool shape	Dimensions in mm							PCEDC	Max. cut depth rel. to $\alpha\eta$ ($\alpha\eta$, ref)*						
				DC	DMM	APMXS	OAL	LN	DN	RE		CA	WDX0	WDX05	WDX1	WDX15	WDX2	WDX3
02968223	JH142020G2R030.0Z2-HXT	2	G	2,0	4	2	40	6	1,9	0,3	6,64	2	6,63	6,96	7,21	7,43	7,62	7,96
02968224	JH142020G2R030.0Z4-HXT	2	G	2,0	4	2	40	6	1,9	0,3	6,64	4	6,63	6,96	7,21	7,43	7,62	7,96
02968225	JH142020G2R050.0Z2-HXT	2	G	2,0	4	2	40	6	1,9	0,5	6,79	2	6,63	6,95	7,2	7,41	7,6	7,93
02968226	JH142020G2R050.0Z4-HXT	2	G	2,0	4	2	40	6	1,9	0,5	6,79	4	6,63	6,95	7,2	7,41	7,6	7,93
02968227	JH142030G2R050.0Z2-HXT	2	G	3,0	4	3	40	8	2,8	0,5	2,95	2	8,92	9,23	9,48	9,71	9,91	10,26
02968228	JH142030G2R050.0Z4-HXT	2	G	3,0	4	3	40	8	2,8	0,5	2,95	4	8,92	9,23	9,48	9,71	9,91	10,26
02968229	JH142030G2R100.0Z2-HXT	2	G	3,0	4	3	40	8	2,8	1,0	3,1	2	8,92	9,21	9,46	9,67	9,87	10,21
02968230	JH142030G2R100.0Z4-HXT	2	G	3,0	4	3	40	8	2,8	1,0	3,1	4	8,92	9,21	9,46	9,67	9,87	10,21
02968231	JH142040G2R030.0Z2-HXT	2	G	4,0	6	4	50	8	3,7	0,3	5,34	2	9,13	9,4	9,64	9,84	10,03	10,37
02970110	JH142040G2R030.0Z4-HXT	2	G	4,0	6	4	50	8	3,7	0,3	5,34	4	9,13	9,4	9,64	9,84	10,03	10,37
02968232	JH142040G2R050.0Z4-HXT	2	G	4,0	6	4	50	8	3,7	0,5	5,44	4	9,13	9,4	9,63	9,83	10,02	10,35
02968233	JH142040G2R100.0Z4-HXT	2	G	4,0	6	4	50	8	3,7	1,0	5,69	4	9,13	9,38	9,6	9,8	9,98	10,3
02968234	JH142060E2R050.0Z2-HXT	2	E	6,0	6	6	50	12	5,6	0,5	-	2	12,0	∞	∞	∞	∞	∞
02968235	JH142060E2R050.0Z4-HXT	2	E	6,0	6	6	50	12	5,6	0,5	-	4	12,0	∞	∞	∞	∞	∞
02968236	JH142060E2R100.0Z2-HXT	2	E	6,0	6	6	50	12	5,6	1,0	-	2	12,0	∞	∞	∞	∞	∞
02968237	JH142060E2R100.0Z4-HXT	2	E	6,0	6	6	50	12	5,6	1,0	-	4	12,0	∞	∞	∞	∞	∞
02968238	JH142060E2R150.0Z5-HXT	2	E	6,0	6	6	50	12	5,6	1,0	-	5	12,0	∞	∞	∞	∞	∞
02968239	JH142060E2R150.0Z2-HXT	2	E	6,0	6	6	50	12	5,6	1,5	-	2	12,0	∞	∞	∞	∞	∞
02968240	JH142060E2R150.0Z5-HXT	2	E	6,0	6	6	50	12	5,6	1,5	-	5	12,0	∞	∞	∞	∞	∞
02968241	JH142060E2R200.0Z5-HXT	2	E	6,0	6	6	50	12	5,6	2,0	-	5	12,0	∞	∞	∞	∞	∞
02968242	JH142080E2R050.0Z5-HXT	2	E	8,0	8	8	60	16	7,4	0,5	-	5	16,0	∞	∞	∞	∞	∞
02968243	JH142080E2R100.0Z5-HXT	2	E	8,0	8	8	60	16	7,4	1,0	-	5	16,0	∞	∞	∞	∞	∞
02968244	JH142080E2R150.0Z5-HXT	2	E	8,0	8	8	60	16	7,4	1,5	-	5	16,0	∞	∞	∞	∞	∞
02968245	JH142080E2R200.0Z5-HXT	2	E	8,0	8	8	60	16	7,4	2,0	-	5	16,0	∞	∞	∞	∞	∞
02968246	JH142080E2R300.0Z5-HXT	2	E	8,0	8	8	60	16	7,4	3,0	-	5	16,0	∞	∞	∞	∞	∞
02968247	JH142100E2R050.0Z5-HXT	2	E	10,0	10	10	70	20	9,4	0,5	-	5	20,0	∞	∞	∞	∞	∞
02968248	JH142100E2R100.0Z5-HXT	2	E	10,0	10	10	70	20	9,4	1,0	-	5	20,0	∞	∞	∞	∞	∞
02968249	JH142100E2R150.0Z5-HXT	2	E	10,0	10	10	70	20	9,4	2,0	-	5	20,0	∞	∞	∞	∞	∞
02968250	JH142100E2R250.0Z5-HXT	2	E	10,0	10	10	70	20	9,4	2,5	-	5	20,0	∞	∞	∞	∞	∞
02968251	JH142120E2R100.0Z6-HXT	2	E	12,0	12	12	75	24	11,4	1,0	-	6	24,0	∞	∞	∞	∞	∞
02968252	JH142120E2R200.0Z6-HXT	2	E	12,0	12	12	75	24	11,4	2,0	-	6	24,0	∞	∞	∞	∞	∞
02968253	JH142120E2R300.0Z6-HXT	2	E	12,0	12	12	75	24	11,4	3,0	-	6	24,0	∞	∞	∞	∞	∞
02968254	JH142120E2R400.0Z6-HXT	2	E	12,0	12	12	75	24	11,4	4,0	-	6	24,0	∞	∞	∞	∞	∞

* The effective under -neck length for the various draft angles. Remark ∞ = infinity, no collision in projection length area.

JH142 – High speed – High precision – Torical – Hardened steel – 2-6 Flutes – Cylindrical – Corner radius



Tolerances:
 Run-out= <0,005 mm
 DMM= h5
 DC= 0-0,01 mm
 RE= ±0,005 mm
 Regrind possible if DC is ≥Ø6

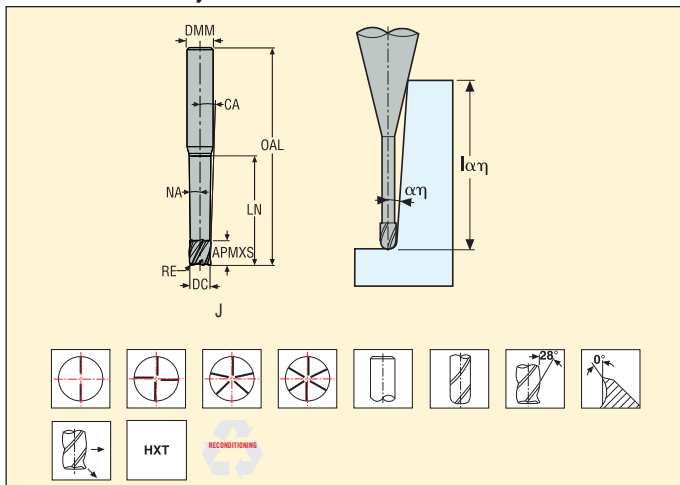

Ordering and Product No.	Designation	Length index	Tool shape	Dimensions in mm							PCEDC	Max. cut depth rel. to αη (lαη, ref)*						
				DC	DMM	APMXS	OAL	LN	DN	RE		CA	WDX0	WDX05	WDX1	WDX15	WDX2	WDX3
02968255	JH14202J3R030.0Z2-HXT	3	J	2,0	6	2	60	10	1,9	0,3	6,72	2	5,23	10,27	10,95	11,31	11,69	12,54
02968256	JH14202J3R030.0Z4-HXT	3	J	2,0	6	2	60	10	1,9	0,3	6,72	4	5,23	10,27	10,95	11,31	11,69	12,54
02968257	JH14202J3R050.0Z2-HXT	3	J	2,0	6	2	60	10	1,9	0,5	6,79	2	5,23	10,24	10,94	11,29	11,66	12,5
02968258	JH14202J3R050.0Z4-HXT	3	J	2,0	6	2	60	10	1,9	0,5	6,79	4	5,23	10,24	10,94	11,29	11,66	12,5
02970111	JH14204J3R030.0Z4-HXT	3	J	4,0	6	4	60	20	3,7	0,3	2,45	4	13,87	20,79	21,52	22,23	22,99	∞
02968259	JH14203J3R050.0Z2-HXT	3	J	3,0	6	3	60	15	2,8	0,5	4,3	2	9,57	15,58	16,22	16,75	17,32	18,57
02968260	JH14203J3R050.0Z4-HXT	3	J	3,0	6	3	60	15	2,8	0,5	4,3	4	9,57	15,58	16,22	16,75	17,32	18,57
02968261	JH14203J3R100.0Z2-HXT	3	J	3,0	6	3	60	15	2,8	1,0	4,4	2	9,57	15,54	16,19	16,7	17,25	18,46
02968262	JH14203J3R100.0Z4-HXT	3	J	3,0	6	3	60	15	2,8	1,0	4,4	4	9,57	15,54	16,19	16,7	17,25	18,46
02968263	JH14204J3R030.0Z2-HXT	3	J	4,0	6	4	60	20	3,7	0,3	2,45	2	13,87	20,79	21,52	22,23	22,99	∞
02968264	JH14204J3R050.0Z4-HXT	3	J	4,0	6	4	60	20	3,7	0,5	2,48	4	13,87	20,78	21,51	22,21	22,97	∞
02968265	JH14204J3R050.0Z2-HXT	3	J	4,0	6	4	60	20	3,7	0,5	2,48	2	13,87	20,78	21,51	22,21	22,97	∞
02968266	JH14204J3R100.0Z2-HXT	3	J	4,0	6	4	60	20	3,7	1,0	2,53	2	13,87	20,76	21,48	22,16	22,9	∞
02968267	JH14204J3R100.0Z4-HXT	3	J	4,0	6	4	60	20	3,7	1,0	2,53	4	13,87	20,76	21,48	22,16	22,9	∞
02968268	JH14206J3R050.0Z4-HXT	3	J	6,0	8	6	75	30	5,6	0,5	1,75	4	19,15	30,85	31,88	32,93	∞	∞
02968269	JH14206J3R050.0Z5-HXT	3	J	6,0	8	6	75	30	5,6	0,5	1,75	5	19,15	30,85	31,88	32,93	∞	∞
02968270	JH14206J3R100.0Z4-HXT	3	J	6,0	8	6	75	30	5,6	1,0	1,77	4	19,15	30,83	31,85	32,88	∞	∞
02968271	JH14206J3R100.0Z5-HXT	3	J	6,0	8	6	75	30	5,6	1,0	1,77	5	19,15	30,83	31,85	32,88	∞	∞
02968272	JH14206J3R150.0Z5-HXT	3	J	6,0	8	6	75	30	5,6	1,5	1,8	5	19,15	30,8	31,82	32,83	∞	∞
02968273	JH14206J3R200.0Z5-HXT	3	J	6,0	8	6	75	30	5,6	2,0	1,83	5	19,15	30,78	31,78	32,78	∞	∞
02968274	JH14208J3R050.0Z5-HXT	3	J	8,0	10	8	85	40	7,4	0,5	1,34	5	27,67	41,12	42,44	∞	∞	∞
02968275	JH14208J3R100.0Z5-HXT	3	J	8,0	10	8	85	40	7,4	1,0	1,36	5	27,67	41,11	42,41	∞	∞	∞
02968276	JH14208J3R150.0Z5-HXT	3	J	8,0	10	8	85	40	7,4	1,5	1,37	5	27,67	41,09	42,38	∞	∞	∞
02968277	JH14208J3R200.0Z5-HXT	3	J	8,0	10	8	85	40	7,4	2,0	1,39	5	27,67	41,08	42,35	∞	∞	∞
02968278	JH14210J3R050.0Z5-HXT	3	J	10,0	12	10	100	50	9,4	0,5	1,1	5	29,67	50,97	52,62	∞	∞	∞
02968279	JH14210J3R100.0Z5-HXT	3	J	10,0	12	10	100	50	9,4	1,0	1,11	5	29,67	50,95	52,59	∞	∞	∞
02968280	JH14210J3R200.0Z5-HXT	3	J	10,0	12	10	100	50	9,4	2,0	1,13	5	29,67	50,91	52,53	∞	∞	∞
02968281	JH14210J3R400.0Z5-HXT	3	J	10,0	12	10	100	50	9,4	4,0	1,17	5	29,67	50,83	52,4	∞	∞	∞
02968282	JH14202J6R030.0Z4-HXT	6	J	2,0	6	2	75	20	1,9	0,3	4,33	4	5,23	11,4	21,0	21,71	22,45	24,11
02968283	JH14202J6R050.0Z4-HXT	6	J	2,0	6	2	75	20	1,9	0,5	4,36	4	5,23	11,14	20,99	21,69	22,43	24,06
02968284	JH14203J6R050.0Z4-HXT	6	J	3,0	6	3	75	30	2,8	0,5	2,52	4	9,57	20,92	31,32	32,35	33,46	∞
02968285	JH14203J6R100.0Z4-HXT	6	J	3,0	6	3	75	30	2,8	1,0	2,56	4	9,57	20,3	31,29	32,31	33,39	∞
02968286	JH14204J6R030.0Z4-HXT	6	J	4,0	6	4	80	40	3,7	0,3	1,36	4	13,87	30,85	41,65	∞	∞	∞
02968287	JH14204J6R050.0Z4-HXT	6	J	4,0	6	4	80	40	3,7	0,5	1,37	4	13,87	30,6	41,65	∞	∞	∞
02968288	JH14204J6R100.0Z4-HXT	6	J	4,0	6	4	80	40	3,7	1,0	1,38	4	13,87	29,98	41,6	∞	∞	∞

* The effective under-neck length for the various draft angles. Remark ∞ = infinity, no collision in projection length area.

Cutting data – JH142 Copy milling roughing

SMG		a _e /DC	a _p /DC	f _z									v _c
				2	3	4	6	8	10	12	16		
P1	M/E	0,050	0,050	0,019	0,028	0,038	0,060	0,075	0,095	0,11	0,14	485 (455 – 540)	
P2	M/E	0,050	0,050	0,020	0,030	0,040	0,060	0,080	0,10	0,12	0,14	470 (440 – 520)	
P3	M/E	0,050	0,050	0,018	0,028	0,036	0,055	0,075	0,090	0,11	0,14	410 (385 – 455)	
P4	M/E	0,050	0,050	0,018	0,028	0,036	0,055	0,070	0,090	0,11	0,13	360 (340 – 400)	
P5	M/E	0,050	0,050	0,018	0,026	0,036	0,055	0,070	0,090	0,10	0,13	345 (325 – 385)	
P6	M/E	0,050	0,050	0,018	0,026	0,036	0,055	0,070	0,090	0,10	0,13	385 (365 – 430)	
P7	M/E	0,050	0,050	0,018	0,026	0,036	0,055	0,070	0,090	0,10	0,13	365 (345 – 405)	
P8	M/E	0,050	0,050	0,018	0,028	0,036	0,055	0,075	0,090	0,11	0,14	345 (325 – 385)	
P11	M/E	0,050	0,050	0,018	0,026	0,036	0,055	0,070	0,090	0,10	0,13	355 (335 – 395)	
K1	A/E	0,050	0,050	0,018	0,026	0,036	0,055	0,070	0,090	0,10	0,13	345 (325 – 385)	
K2	A/E	0,050	0,050	0,016	0,024	0,032	0,048	0,065	0,080	0,095	0,12	305 (285 – 335)	
K3	A/E	0,050	0,050	0,016	0,024	0,032	0,048	0,065	0,080	0,095	0,12	255 (240 – 285)	
K4	A/E	0,050	0,050	0,016	0,024	0,032	0,048	0,065	0,080	0,095	0,12	245 (230 – 270)	
K5	A/E	0,050	0,050	0,018	0,026	0,036	0,055	0,070	0,090	0,10	0,13	345 (325 – 385)	
K6	A/E	0,050	0,050	0,020	0,030	0,040	0,060	0,080	0,10	0,12	0,15	500 (475 – 560)	
K7	A/E	0,050	0,050	0,018	0,026	0,036	0,055	0,070	0,090	0,10	0,13	440 (415 – 490)	
H3	M/A	0,020	0,020	0,010	0,016	0,020	0,032	0,042	0,050	0,060	0,075	95 (70 – 120)	
H5	M/A	0,040	0,040	0,013	0,020	0,026	0,040	0,055	0,065	0,080	0,095	310 (280 – 335)	
H7	M/A	0,020	0,020	0,010	0,016	0,020	0,032	0,042	0,050	0,060	0,075	95 (70 – 120)	
H8	M/A	0,040	0,040	0,0090	0,014	0,018	0,028	0,036	0,046	0,055	0,070	315 (290 – 340)	
H11	M/A	0,040	0,040	0,013	0,020	0,026	0,040	0,055	0,065	0,080	0,095	390 (360 – 425)	
H12	M/A	0,050	0,050	0,0055	0,0085	0,011	0,017	0,022	0,028	0,034	0,042	355 (325 – 385)	
H21	M/A	0,040	0,040	0,0090	0,014	0,018	0,028	0,036	0,046	0,055	0,070	315 (290 – 340)	
H31	M/A	0,030	0,030	0,011	0,016	0,022	0,032	0,044	0,055	0,065	0,080	140 (120 – 170)	

For cutting data recalculations, see page 411-418.

SMG = Seco material group

Coolant = A=air D=dry E=emulsion M=mist spray

v_c = m/min

f_z = mm

a_p (mm)/DC (mm)= factor

a_e (mm)/DC (mm)= factor

All cutting data are target values

JH970 – High speed – Universal – Ball nose – 2 Flutes – Cylindrical



Tolerances:
 DMM= h5
 DC= -0,02/-0,04 mm
 RE= ±0,01 mm
 Regrind possible if DC is ≥Ø6

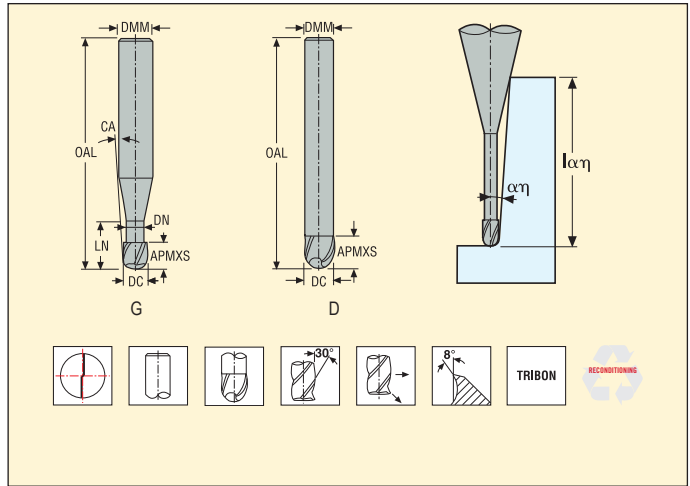

Ordering and Product No.	Designation	Length index	Tool shape	Dimensions in mm							PCEDC	Max. cut depth rel. to $\alpha\eta$ ($\alpha\eta$, ref)*					
				DC	DMM	APMXS	OAL	LN	DN	CA		WDX0	WDX05	WDX1	WDX15	WDX2	WDX3
02452881	970021-TRIBON	1	G	2,0	3	3,0	50	10	1,9	2,5	2	10,0	11,0	11,5	12,1	12,8	∞
02452882	970031-TRIBON	1	D	3,0	3	4,5	50	-	-	-	2	4,5	∞	∞	∞	∞	∞
02452883	970041-TRIBON	1	D	4,0	4	6,0	60	-	-	-	2	6,0	∞	∞	∞	∞	∞
02452884	970051-TRIBON	1	D	5,0	5	7,5	60	-	-	-	2	7,5	∞	∞	∞	∞	∞
02452885	970061-TRIBON	1	D	6,0	6	9,0	75	-	-	-	2	9,0	∞	∞	∞	∞	∞
02452886	970020-TRIBON	2	G	2,0	6	3,0	60	4	1,9	8,0	2	4,0	4,7	4,9	5,1	5,4	6,0
02452887	970025-TRIBON	2	G	2,5	6	4,0	60	5	2,4	7,5	2	5,0	5,7	6,0	6,2	6,5	7,3
02452888	970030-TRIBON	2	G	3,0	6	4,5	60	6	2,8	5,5	2	6,0	7,4	7,8	8,3	9,0	10,6
02452889	970035-TRIBON	2	G	3,5	6	5,0	60	7	3,2	4,5	2	7,0	8,8	9,4	10,0	10,7	12,8
02452890	970040-TRIBON	2	G	4,0	6	6,0	60	8	3,7	3,0	2	8,0	10,8	11,9	13,3	15,2	∞
02452891	970050-TRIBON	2	G	5,0	6	7,5	60	10	4,6	2,0	2	10,0	13,6	15,0	16,8	∞	∞
02452892	970060-TRIBON	2	G	6,0	8	9,0	75	12	5,6	2,5	2	12,0	15,8	17,4	19,4	22,2	∞
02452893	970080-TRIBON	2	D	8,0	8	12,0	75	-	-	-	2	12,0	∞	∞	∞	∞	∞
02452894	970100-TRIBON	2	D	10,0	10	15,0	80	-	-	-	2	15,0	∞	∞	∞	∞	∞
02452895	970120-TRIBON	2	D	12,0	12	18,0	90	-	-	-	2	18,0	∞	∞	∞	∞	∞
02452896	970160-TRIBON	2	D	16,0	16	24,0	100	-	-	-	2	24,0	∞	∞	∞	∞	∞
02452899	970L020-TRIBON	3	G	2,0	6	3,0	80	4	1,9	8,0	2	4,0	4,7	4,9	5,1	5,4	6,0
02452900	970L030-TRIBON	3	G	3,0	6	4,5	80	6	2,8	5,5	2	6,0	7,4	7,8	8,3	9,0	10,6
02452901	970L040-TRIBON	3	G	4,0	6	6,0	80	8	3,7	3,0	2	8,0	10,8	11,9	13,3	15,2	∞
02452902	970L050-TRIBON	3	G	5,0	6	7,5	100	10	4,6	2,0	2	10,0	13,6	15,0	16,8	∞	∞
02452903	970L060-TRIBON	3	G	6,0	8	9,0	100	12	5,6	2,5	2	12,0	15,8	17,4	19,4	22,2	∞
02452904	970L080-TRIBON	3	D	8,0	8	12,0	110	-	-	-	2	12,0	∞	∞	∞	∞	∞
02452905	970L100-TRIBON	3	D	10,0	10	15,0	125	-	-	-	2	15,0	∞	∞	∞	∞	∞
02452906	970L120-TRIBON	3	D	12,0	12	18,0	125	-	-	-	2	18,0	∞	∞	∞	∞	∞
02452907	970L160-TRIBON	3	D	16,0	16	24,0	150	-	-	-	2	24,0	∞	∞	∞	∞	∞

* The effective under-neck length for the various draft angles. Remark ∞ = infinity, no collision in projection length area.

Cutting data – JH970 Copy milling roughing

SMG		a _e /DC	a _p /DC	f _z										v _c
				2	3	4	5	6	8	10	12	16		
P1	M	0,35	0,070	0,040	0,060	0,080	0,10	0,12	0,16	0,20	0,24	0,32	245 (210 – 275)	
P2	M	0,35	0,070	0,040	0,060	0,080	0,10	0,12	0,16	0,20	0,24	0,32	240 (205 – 270)	
P3	M	0,35	0,070	0,040	0,060	0,080	0,10	0,12	0,16	0,20	0,24	0,32	205 (180 – 230)	
P4	M	0,35	0,070	0,040	0,060	0,080	0,10	0,12	0,16	0,20	0,24	0,32	180 (155 – 205)	
P5	M	0,35	0,070	0,040	0,060	0,080	0,10	0,12	0,16	0,20	0,24	0,32	170 (150 – 195)	
P6	M	0,35	0,070	0,040	0,060	0,080	0,10	0,12	0,16	0,20	0,24	0,32	195 (170 – 220)	
P7	M	0,35	0,070	0,040	0,060	0,080	0,10	0,12	0,16	0,20	0,24	0,32	185 (160 – 205)	
P8	M	0,35	0,070	0,040	0,060	0,080	0,10	0,12	0,16	0,20	0,24	0,32	170 (150 – 195)	
P11	M	0,35	0,070	0,040	0,060	0,080	0,10	0,12	0,16	0,20	0,24	0,32	180 (155 – 200)	
P12	M	0,35	0,055	0,032	0,048	0,065	0,080	0,10	0,13	0,16	0,20	0,26	110 (95 – 125)	
M1	M	0,17	1,0	0,020	0,030	0,040	0,050	0,060	0,080	0,10	0,12	0,16	95 (85 – 110)	
M2	M	0,17	1,0	0,020	0,030	0,040	0,050	0,060	0,080	0,10	0,12	0,16	80 (70 – 90)	
M3	M	0,13	1,0	0,022	0,032	0,042	0,055	0,065	0,085	0,11	0,13	0,16	65 (55 – 75)	
M4	M	0,13	0,80	0,020	0,030	0,040	0,050	0,060	0,080	0,10	0,12	0,14	50 (44 – 60)	
M5	M	0,13	0,80	0,020	0,030	0,040	0,050	0,060	0,080	0,10	0,12	0,14	43 (37 – 50)	
S1	E	0,15	0,065	0,040	0,060	0,080	0,10	0,12	0,16	0,20	0,24	0,30	50 (41 – 60)	
S2	E	0,15	0,065	0,040	0,060	0,080	0,10	0,12	0,16	0,20	0,24	0,30	42 (33 – 50)	
S3	E	0,12	0,060	0,038	0,055	0,075	0,095	0,11	0,15	0,19	0,22	0,28	31 (21 – 42)	
S11	E	0,35	0,14	0,012	0,018	0,024	0,030	0,036	0,048	0,060	0,070	0,095	105 (90 – 120)	
S12	E	0,35	0,14	0,012	0,018	0,024	0,030	0,036	0,048	0,060	0,070	0,095	80 (70 – 90)	
S13	E	0,35	0,12	0,012	0,018	0,024	0,030	0,036	0,048	0,060	0,070	0,095	60 (55 – 70)	

For cutting data recalculations, see page 411-418.

SMG = Seco material group

Coolant = A=air D=dry E=emulsion M=mist spray

v_c = m/min

f_z = mm

a_p (mm)/DC (mm)= factor

a_e (mm)/DC (mm)= factor

All cutting data are target values

JH112 – High speed – High precision – Hardened steel – Ball nose – 2 Flutes – Cylindrical



Tolerances:
 Run-out= <0,005 mm
 DMM= h5
 DC= 0-0,01 mm
 RE= ±0,005 mm
 Regrind possible if DC is ≥Ø6

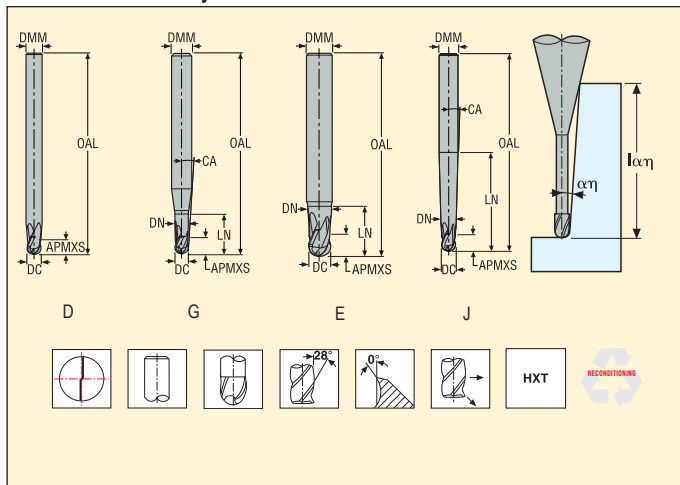

Ordering and Product No.	Designation	Length index	Tool shape	Dimensions in mm							PCE/DC	Max. cut depth rel. to αη (lαη, ref)*					
				DC	DMM	APMXS	OAL	LN	DN	CA		WDX0	WDX05	WDX1	WDX15	WDX2	WDX3
02970112	JH112020G1B.0Z2-HXT	1	G	2,0	4	2	40	4	1,9	6,45	2	4,66	4,84	5,03	5,24	5,47	6,03
02970113	JH112030G1B.0Z2-HXT	1	G	3,0	4	3	40	6	2,8	3,3	2	6,96	7,29	7,66	8,08	8,56	9,78
02970114	JH112040D1B.0Z2-HXT	1	D	4,0	4	4	40	-	-	-	2	4,0	∞	∞	∞	∞	∞
02970115	JH112050G1B.0Z2-HXT	1	G	5,0	6	5	50	10	4,6	2,0	2	12,09	12,96	14,01	15,29	16,89	∞
02970116	JH112060D1B.0Z2-HXT	1	D	6,0	6	6	50	-	-	-	2	6,0	∞	∞	∞	∞	∞
02970117	JH112080D1B.0Z2-HXT	1	D	8,0	8	8	65	-	-	-	2	8,0	∞	∞	∞	∞	∞
02970118	JH112100D1B.0Z2-HXT	1	D	10,0	10	10	65	-	-	-	2	10,0	∞	∞	∞	∞	∞
02970119	JH112020G2B.0Z2-HXT	2	G	2,0	3	2	50	10	1,9	2,5	2	10,79	11,1	11,42	11,77	∞	∞
02970120	JH112030D2B.0Z2-HXT	2	D	3,0	3	3	50	-	-	-	2	∞	∞	∞	∞	∞	∞
02970121	JH112040D2B.0Z2-HXT	2	D	4,0	4	4	60	-	-	-	2	4,0	∞	∞	∞	∞	∞
02970122	JH112050D2B.0Z2-HXT	2	D	5,0	5	5	60	-	-	-	2	5,0	∞	∞	∞	∞	∞
02970123	JH112060D2B.0Z2-HXT	2	D	6,0	6	6	75	-	-	-	2	6,0	∞	∞	∞	∞	∞
02970124	JH112020G3B.0Z2-HXT	3	G	2,0	6	2	60	4	1,9	8,12	2	4,66	4,84	5,03	5,24	5,47	6,03
02970125	JH112025G3B.0Z2-HXT	3	G	2,5	6	3	60	5	2,4	7,39	2	5,66	5,87	6,1	6,36	6,64	7,31
02970126	JH112030G3B.0Z2-HXT	3	G	3,0	6	3	60	6	2,8	5,5	2	6,97	7,31	7,7	8,14	8,65	9,95
02968289	JH112035G3B.0Z2-HXT	3	G	3,5	6	4	65	7	3,2	3,81	2	8,62	9,24	9,99	10,9	12,05	15,49
02970127	JH112040G3B.0Z2-HXT	3	G	4,0	6	4	65	8	3,7	3,34	2	9,62	10,31	11,14	12,15	13,42	17,25
02970128	JH112050G3B.0Z2-HXT	3	G	5,0	6	5	65	10	4,6	2,0	2	12,09	12,96	14,01	15,29	16,89	∞
02970129	JH112060G3B.0Z2-HXT	3	G	6,0	8	6	75	12	5,6	2,78	2	14,09	15,1	16,31	17,79	19,64	25,2
02968290	JH112080E3B.0Z2-HXT	3	E	8,0	8	8	75	16	7,4	-	2	16,0	∞	∞	∞	∞	∞
02968291	JH112100E3B.0Z2-HXT	3	E	10,0	10	10	80	20	9,4	-	2	20,0	∞	∞	∞	∞	∞
02968292	JH112120E3B.0Z2-HXT	3	E	12,0	12	12	90	24	11,4	-	2	24,0	∞	∞	∞	∞	∞
02970130	JH112020G4B.0Z2-HXT	4	G	2,0	6	2	80	20	1,9	3,82	2	20,66	21,59	22,61	23,73	24,98	27,94
02970131	JH112030G4B.0Z2-HXT	4	G	3,0	6	3	80	20	2,8	2,91	2	20,97	22,18	23,55	25,11	26,92	31,51
02970132	JH112040G4B.0Z2-HXT	4	G	4,0	6	4	80	20	3,7	1,97	2	21,62	23,39	25,53	28,13	∞	∞
02970133	JH112050G4B.0Z2-HXT	4	G	5,0	6	5	100	50	4,6	0,53	2	52,09	56,58	∞	∞	∞	∞
02968293	JH112060D4B.0Z2-HXT	4	D	6,0	6	6	100	-	5,6	-	2	6,0	∞	∞	∞	∞	∞
02968294	JH112080D4B.0Z2-HXT	4	D	8,0	8	8	110	-	7,4	-	2	8,0	∞	∞	∞	∞	∞
02968295	JH112100D4B.0Z2-HXT	4	D	10,0	10	10	125	-	9,4	-	2	10,0	∞	∞	∞	∞	∞
02968296	JH112120D4B.0Z2-HXT	4	D	12,0	12	12	125	-	11,4	-	2	12,0	∞	∞	∞	∞	∞
02970134	JH112020J5B.0Z2-HXT	5	J	2,0	6	2	80	-	1,9	3,3	2	3,09	3,43	3,91	4,63	5,81	14,63
02970135	JH112030J5B.0Z2-HXT	5	J	3,0	6	3	80	-	2,8	2,2	2	5,7	6,75	8,51	12,03	22,61	∞
02970136	JH112040J5B.0Z2-HXT	5	J	4,0	6	4	80	-	3,7	1,2	2	10,58	15,35	32,07	∞	∞	∞
02970137	JH112050J5B.0Z2-HXT	5	J	5,0	8	5	100	-	4,6	1,6	2	11,47	14,56	20,93	41,46	∞	∞
02970138	JH112060J5B.0Z2-HXT	5	J	6,0	8	6	100	-	5,6	1,1	2	14,72	21,24	44,08	∞	∞	∞
02970139	JH112080J5B.0Z2-HXT	5	J	8,0	10	8	125	-	7,4	1,0	2	20,71	29,7	59,65	∞	∞	∞

* The effective under-neck length for the various draft angles. Remark ∞ = infinity, no collision in projection length area.

Cutting data – JH112 Copy milling finishing

SMG		a _p /DC	f _z										v _c
			2	2,5	3	3,5	4	5	6	8	10	12	
K1	E	0,30	0,030	0,038	0,044	0,050	0,060	0,075	0,090	0,12	0,15	0,18	520 (490 – 740)
K2	E	0,30	0,030	0,038	0,044	0,050	0,060	0,075	0,090	0,12	0,15	0,18	445 (425 – 640)
K3	E	0,30	0,030	0,038	0,044	0,050	0,060	0,075	0,090	0,12	0,15	0,18	380 (360 – 540)
K4	E	0,30	0,030	0,038	0,044	0,050	0,060	0,075	0,090	0,12	0,15	0,18	360 (345 – 520)
K5	E	0,30	0,030	0,036	0,044	0,050	0,060	0,075	0,090	0,12	0,15	0,17	415 (370 – 610)
K6	E	0,30	0,030	0,038	0,044	0,050	0,060	0,075	0,090	0,12	0,15	0,18	610 (540 – 910)
K7	E	0,30	0,030	0,038	0,044	0,050	0,060	0,075	0,090	0,12	0,15	0,18	680 (560 – 800)
H3	M	0,16	0,028	0,036	0,042	0,048	0,055	0,070	0,085	0,11	0,14	0,17	155 (140 – 235)
H5	M	0,30	0,030	0,038	0,044	0,050	0,060	0,075	0,090	0,12	0,15	0,18	285 (235 – 335)
H7	M	0,16	0,028	0,036	0,042	0,048	0,055	0,070	0,085	0,11	0,14	0,17	155 (140 – 235)
H8	M	0,30	0,028	0,034	0,042	0,048	0,055	0,070	0,085	0,11	0,14	0,17	285 (235 – 335)
H11	M	0,30	0,030	0,038	0,044	0,050	0,060	0,075	0,090	0,12	0,15	0,18	360 (295 – 425)
H12	M	0,30	0,028	0,034	0,042	0,048	0,055	0,070	0,085	0,11	0,14	0,17	330 (275 – 390)
H21	M	0,30	0,028	0,034	0,042	0,048	0,055	0,070	0,085	0,11	0,14	0,17	285 (235 – 335)
H31	M	0,30	0,026	0,032	0,040	0,046	0,050	0,065	0,080	0,10	0,13	0,16	300 (290 – 435)

Cutting data – JH112 Copy milling roughing

SMG		a _g /DC	a _p /DC	f _z										v _c
				2	2,5	3	3,5	4	5	6	8	10	12	
K1	E	0,25	0,14	0,030	0,038	0,044	0,050	0,060	0,075	0,090	0,12	0,15	0,18	315 (300 – 450)
K2	E	0,25	0,14	0,030	0,036	0,044	0,050	0,060	0,075	0,090	0,12	0,15	0,17	275 (260 – 390)
K3	E	0,25	0,14	0,030	0,036	0,044	0,050	0,060	0,075	0,090	0,12	0,15	0,17	235 (220 – 330)
K4	E	0,25	0,14	0,030	0,036	0,044	0,050	0,060	0,075	0,090	0,12	0,15	0,17	220 (210 – 315)
K5	E	0,16	0,14	0,028	0,036	0,042	0,050	0,055	0,070	0,085	0,11	0,14	0,17	285 (255 – 425)
K6	E	0,16	0,14	0,030	0,038	0,044	0,050	0,060	0,075	0,090	0,12	0,15	0,18	415 (370 – 620)
K7	E	0,25	0,12	0,030	0,038	0,044	0,050	0,060	0,075	0,090	0,12	0,15	0,18	420 (345 – 490)
H3	M	0,12	0,040	0,028	0,036	0,042	0,048	0,055	0,070	0,085	0,11	0,14	0,17	110 (100 – 165)
H5	M	0,25	0,095	0,030	0,038	0,044	0,050	0,060	0,075	0,090	0,12	0,15	0,18	175 (145 – 205)
H7	M	0,12	0,034	0,028	0,036	0,042	0,048	0,055	0,070	0,085	0,11	0,14	0,17	110 (100 – 165)
H8	M	0,25	0,080	0,028	0,034	0,042	0,048	0,055	0,070	0,085	0,11	0,14	0,17	180 (145 – 210)
H11	M	0,25	0,095	0,030	0,038	0,044	0,050	0,060	0,075	0,090	0,12	0,15	0,18	225 (185 – 265)
H12	M	0,25	0,080	0,028	0,034	0,042	0,048	0,055	0,070	0,085	0,11	0,14	0,17	210 (170 – 245)
H21	M	0,25	0,080	0,028	0,034	0,042	0,048	0,055	0,070	0,085	0,11	0,14	0,17	180 (145 – 210)
H31	M	0,20	0,095	0,026	0,032	0,040	0,046	0,050	0,065	0,080	0,10	0,13	0,16	200 (190 – 285)

For cutting data recalculations, see page 411-418.

SMG = Seco material group

Coolant = A=air D=dry E=emulsion M=mist spray

v_c = m/min

f_z = mm

a_p (mm)/DC (mm)= factor

a_g (mm)/DC (mm)= factor

All cutting data are target values

Cutting data – JH150 Copy milling roughing

SMG		a _e /DC	a _p /DC	f _z					v _c
				6	8	10	12		
K1	A	0,30	0,14	0,10	0,14	0,17	0,20	290 (310 – 375)	
K2	A	0,30	0,14	0,10	0,14	0,17	0,20	250 (265 – 325)	
K3	A	0,30	0,14	0,10	0,14	0,17	0,20	210 (225 – 275)	
K5	A	0,20	0,14	0,10	0,14	0,17	0,20	255 (265 – 340)	
K6	A	0,20	0,14	0,10	0,14	0,17	0,20	375 (390 – 500)	
K7	A	0,20	0,14	0,10	0,14	0,17	0,20	325 (340 – 435)	
H3	M	0,050	0,020	0,085	0,11	0,14	0,17	85 (90 – 125)	
H5	M	0,20	0,060	0,10	0,14	0,17	0,20	180 (160 – 200)	
H7	M	0,050	0,017	0,085	0,11	0,14	0,17	85 (85 – 120)	
H8	M	0,20	0,050	0,095	0,12	0,16	0,19	180 (160 – 205)	
H11	M	0,20	0,060	0,10	0,14	0,17	0,20	230 (205 – 255)	
H12	M	0,20	0,050	0,095	0,12	0,16	0,19	210 (185 – 235)	
H21	M	0,20	0,050	0,095	0,12	0,16	0,19	180 (160 – 205)	
H31	M	0,15	0,060	0,090	0,12	0,15	0,18	125 (120 – 185)	

For cutting data recalculations, see page 411-418.

SMG = Seco material group

Coolant = A=air D=dry E=emulsion M=mist spray

v_c = m/min

f_z = mm

a_p (mm)/DC (mm)= factor

a_e (mm)/DC (mm)= factor

All cutting data are target values

Cutting data – JH160 Copy milling finishing

SMG		a _e /DC	a _p /DC	f _z							v _c
				4	5	6	8	10	12		
P1	M/E/A	0,020	0,022	0,070	0,085	0,10	0,14	0,17	0,20	540 (445 – 710)	
P2	M/E/A	0,020	0,022	0,070	0,085	0,10	0,14	0,17	0,20	530 (435 – 690)	
P3	M/E/A	0,020	0,022	0,070	0,085	0,10	0,14	0,17	0,20	455 (375 – 590)	
P4	M/E/A	0,020	0,022	0,070	0,085	0,10	0,14	0,17	0,20	400 (330 – 520)	
P5	M/E/A	0,020	0,022	0,070	0,085	0,10	0,14	0,17	0,20	385 (315 – 495)	
P6	M/E/A	0,020	0,022	0,070	0,085	0,10	0,14	0,17	0,20	430 (355 – 560)	
P7	M/E/A	0,020	0,022	0,070	0,085	0,10	0,14	0,17	0,20	405 (335 – 530)	
P8	M/E/A	0,020	0,022	0,070	0,085	0,10	0,14	0,17	0,20	385 (315 – 495)	
P11	M/E/A	0,020	0,022	0,070	0,085	0,10	0,14	0,17	0,20	395 (325 – 510)	
P12	M/E/A	0,020	0,022	0,060	0,075	0,090	0,12	0,15	0,18	235 (195 – 305)	
H3	M/E/A	0,010	0,0075	0,050	0,065	0,080	0,10	0,13	0,16	85 (90 – 115)	
H5	M/E/A	0,010	0,015	0,050	0,065	0,080	0,10	0,13	0,16	335 (315 – 360)	
H7	M/E/A	0,010	0,0075	0,050	0,065	0,080	0,10	0,13	0,16	85 (90 – 115)	
H8	M/E/A	0,010	0,015	0,050	0,065	0,080	0,10	0,13	0,16	335 (315 – 360)	
H11	M/E/A	0,010	0,015	0,050	0,065	0,080	0,10	0,13	0,16	430 (400 – 460)	
H12	M/E/A	0,020	0,022	0,046	0,055	0,070	0,090	0,11	0,14	365 (340 – 390)	
H21	M/E/A	0,010	0,015	0,050	0,065	0,080	0,10	0,13	0,16	335 (315 – 360)	
H31	M/E/A	0,010	0,015	0,050	0,065	0,080	0,10	0,13	0,16	165 (175 – 215)	

For cutting data recalculations, see page 411-418.

SMG = Seco material group

Coolant = A=air D=dry E=emulsion M=mist spray

v_c = m/min

f_z = mm

a_p (mm)/DC (mm)= factor

a_e (mm)/DC (mm)= factor

All cutting data are target values



Name		JS754	JS755	JS720	JS730	JHP750	JHP760	JHP770	JHP780	JH770
Page(s)		178 - 194	195 - 205	206-212	213-216	217-219	220-222	223-230	231-235	236-237
Family name		JS ²	JS ²	JS ²	JS ²	HPM	HPM	HPM	HPM	HSM/ TORNADO
Type of mill										
Shank	Cylindrical	■	■	■	■	■	■	■	■	■
	Weldon	■	■	■	□	■	■	■	■	
	Safelock	□	□	□	□					
Number of Flutes		4	5	6	6	2-4	2-4	4-5	4	3-6
ICC		■					■	■		
Diameter range	Metric	3-25	6-25	6-25	6-25	2-25	4-25	6-25	6-25	6-10
	Inch									
Length availability										
Operation										
SMG										
P11- P12		○	○							
M1		●	●	●	●		●			
M2		●	●	●	●		●			
M3		●	●	●	●		●			
M4		●	●	●	●		●			
M5		●	●	●	●		●			
N1				●						
N2-3										
N11				●						
S1						●			●	
S2						●			●	●
S3						●			●	
S11		●	●	●	●	●		●		●
S12		●	●	●	●	●		●		●
S13		●	●	●	●	●		●		
TS1				●						
TP1				●						























■ Stock standard □ Weldon available, delivery time is 3 days.

● Preferred choice ○ Alternative choice

Name		JH740	JH710	JH790	JH730	JHP994	JH780
Page(s)		238-239	240-241	242-243	244-245	246- 247	248-249
Family name		HSM/TORNADO	HSM/TORNADO	HSM/TORNADO	HSM/TORNADO	HPM	HSM/TORNADO
Type of mill							
Shank	Cylindrical	■	■	■	■	■	■
	Weldon						
	Safelock						
Number of Flutes		4-5	5	3	6-7	4	4
ICC							
Diameter range	Metric	6-10	6-8	9,5	8-10	6-10	1,83-4,89
	Inch						
Length availability		 2	 2	 2-3	 2	 3	 2
Operation							
SMG							
M1							
M2							
M3							
M4							
M5							
S1							
S2		•	•	•	•	•	•
S3							
S11		•	•	•	•	•	•
S12		•	•	•	•	•	•
S13							

■ Stock standard □ Weldon available, delivery time is 3 days.

• Preferred choice ○ Alternative choice

					
					
Name		JH720	JH721	JH722	JCO710
Page(s)		250-251	252-253	254-255	256-260
Family name		HSM/TORNADO	HSM/TORNADO	HSM/TORNADO	Hss-Co
Type of mill					
Shank	Cylindrical	■	■	■	
	Weldon				■
	Safelock				
Number of Flutes		3	6	3	4-6
ICC					
Diameter range	Metric	2-16	6-8	10	16-50
	Inch				
Length availability		 2	 2	 2	 2,4
Operation					
					
SMG					
M1		●			●
M2		●			●
M3		●			●
M4		●			●
M5		●			●
N1		●			
N2-3					
N11		●			
S1		○			
S2		○		●	
S3		○	●	●	
S11		●	●	●	●
S12		●	●	●	●
S13		●			●
TS1		●			
TP1		●			

■ Stock standard □ Weldon available, delivery time is 3 days.
● Preferred choice ○ Alternative choice

JS754 – High performance – Square – ISO-M and ISO-S – 4 Flutes – Cylindrical – Corner radius



Tolerances:
 DMM= h5
 DC= e7
 RE= ±0,01 mm
 Regrind possible if DC is ≥Ø6

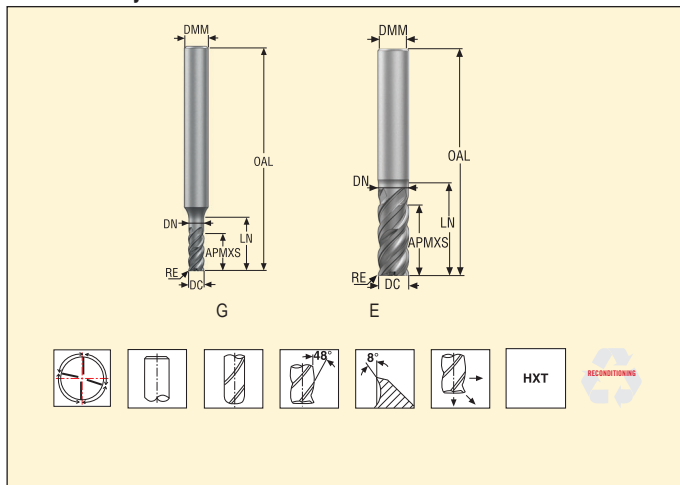

Ordering and Product No.	Designation	Length index	Tool shape	Dimensions in mm							PCEDC	Cylindrical
				DC	DMM	APMXS	OAL	LN	DN	RE		
03186840	JS754030G2R020.0Z4-HXT	2	G	3,0	6	6,0	57	10,0	2,85	0,2	4	■
03186841	JS754040G2R020.0Z4-HXT	2	G	4,0	6	8,0	57	13,0	3,8	0,2	4	■
03186842	JS754050G2R020.0Z4-HXT	2	G	5,0	6	10,0	57	16,0	4,75	0,2	4	■
03186843	JS754060E2R020.0Z4-HXT	2	E	6,0	6	12,0	57	18,0	5,7	0,2	4	■
03186844	JS754060E2R050.0Z4-HXT	2	E	6,0	6	12,0	57	18,0	5,7	0,5	4	■
03186845	JS754060E2R100.0Z4-HXT	2	E	6,0	6	12,0	57	18,0	5,7	1,0	4	■
03186846	JS754080E2R050.0Z4-HXT	2	E	8,0	8	16,0	63	25,0	7,6	0,5	4	■
03186847	JS754080E2R100.0Z4-HXT	2	E	8,0	8	16,0	63	25,0	7,6	1,0	4	■
03186848	JS754100E2R050.0Z4-HXT	2	E	10,0	10	20,0	72	29,0	9,5	0,5	4	■
03186849	JS754100E2R100.0Z4-HXT	2	E	10,0	10	20,0	72	29,0	9,5	1,0	4	■
03200552	JS754100E2R150.0Z4-HXT	2	E	10,0	10	20,0	72	29,0	9,5	1,5	4	■
03186850	JS754100E2R200.0Z4-HXT	2	E	10,0	10	20,0	72	29,0	9,5	2,0	4	■
03186851	JS754100E2R300.0Z4-HXT	2	E	10,0	10	20,0	72	29,0	9,5	3,0	4	■
03186852	JS754120E2R050.0Z4-HXT	2	E	12,0	12	24,0	83	35,0	11,4	0,5	4	■
03186853	JS754120E2R100.0Z4-HXT	2	E	12,0	12	24,0	83	35,0	11,4	1,0	4	■
03200553	JS754120E2R150.0Z4-HXT	2	E	12,0	12	24,0	83	35,0	11,4	1,5	4	■
03186854	JS754120E2R200.0Z4-HXT	2	E	12,0	12	24,0	83	35,0	11,4	2,0	4	■
03186855	JS754120E2R300.0Z4-HXT	2	E	12,0	12	24,0	83	35,0	11,4	3,0	4	■
03186856	JS754160E2R050.0Z4-HXT	2	E	16,0	16	32,0	92	42,0	15,2	0,5	4	■
03186857	JS754160E2R100.0Z4-HXT	2	E	16,0	16	32,0	92	42,0	15,2	1,0	4	■
03186858	JS754160E2R200.0Z4-HXT	2	E	16,0	16	32,0	92	42,0	15,2	2,0	4	■
03186859	JS754160E2R300.0Z4-HXT	2	E	16,0	16	32,0	92	42,0	15,2	3,0	4	■
03186860	JS754160E2R400.0Z4-HXT	2	E	16,0	16	32,0	92	42,0	15,2	4,0	4	■
03186861	JS754160E2R600.0Z4-HXT	2	E	16,0	16	32,0	92	42,0	15,2	6,0	4	■
03186862	JS754200E2R050.0Z4-HXT	2	E	20,0	20	40,0	104	51,0	19,0	0,5	4	■
03186863	JS754200E2R100.0Z4-HXT	2	E	20,0	20	40,0	104	51,0	19,0	1,0	4	■
03186864	JS754200E2R200.0Z4-HXT	2	E	20,0	20	40,0	104	51,0	19,0	2,0	4	■
03186865	JS754200E2R300.0Z4-HXT	2	E	20,0	20	40,0	104	51,0	19,0	3,0	4	■
03186866	JS754200E2R400.0Z4-HXT	2	E	20,0	20	40,0	104	51,0	19,0	4,0	4	■
03186867	JS754200E2R600.0Z4-HXT	2	E	20,0	20	40,0	104	51,0	19,0	6,0	4	■

Stock standard. Subject to change refer to current price- and stock-list

Cutting data – JS754 Side milling roughing

SMG		a _p /DC	a _p /DC	f _z										v _c
				3	4	5	6	8	10	12	16	20	25	
P11	M/A/D/E	0.40	0.80	0,026	0,036	0,044	0,055	0,070	0,090	0,11	0,13	0,15	0,17	160 (125 – 190)
P12	M/A/D/E	0.40	0.80	0,018	0,024	0,030	0,036	0,048	0,060	0,070	0,090	0,10	0,12	105 (80 – 120)
M1	E	0.40	1.0	0,020	0,026	0,034	0,040	0,055	0,065	0,080	0,10	0,11	0,13	110 (95 – 135)
M2	E	0.40	1.0	0,018	0,024	0,030	0,036	0,048	0,060	0,070	0,090	0,10	0,12	90 (80 – 110)
M3	E	0.40	0.90	0,015	0,020	0,025	0,030	0,040	0,050	0,060	0,075	0,085	0,095	60 (45 – 75)
M4	E	0.40	0.90	0,013	0,018	0,022	0,026	0,036	0,044	0,055	0,065	0,075	0,085	46 (35 – 60)
M5	E	0.40	0.90	0,013	0,018	0,022	0,026	0,036	0,044	0,055	0,065	0,075	0,085	39 (30 – 50)
S1	E	0.15	0.50	0,026	0,034	0,044	0,050	0,070	0,085	0,10	0,13	0,15	0,17	50 (25 – 70)
S2	E	0.15	0.50	0,026	0,034	0,044	0,050	0,070	0,085	0,10	0,13	0,15	0,17	41 (20 – 55)
S3	E	0.15	0.50	0,024	0,032	0,040	0,048	0,065	0,080	0,095	0,12	0,14	0,15	36 (20 – 50)
S11	E	0.40	0.70	0,015	0,020	0,025	0,030	0,040	0,050	0,060	0,080	0,10	0,12	115 (75 – 150)
S12	E	0.40	0.70	0,015	0,020	0,025	0,030	0,040	0,050	0,060	0,080	0,10	0,12	85 (60 – 115)
S13	E	0.40	0.70	0,015	0,020	0,025	0,030	0,040	0,050	0,060	0,080	0,090	0,10	65 (45 – 90)

Cutting data – JS754 Slot milling

SMG		a _p /DC	f _z										v _c
			3	4	5	6	8	10	12	16	20	25	
P11	M/A/D/E	0.80	0,015	0,020	0,025	0,030	0,040	0,050	0,060	0,080	0,10	0,13	145 (115 – 170)
P12	M/A/D/E	0.80	0,015	0,020	0,025	0,030	0,040	0,050	0,060	0,080	0,10	0,11	85 (70 – 100)
M1	E	0.80	0,012	0,016	0,020	0,024	0,032	0,040	0,048	0,065	0,080	0,10	95 (85 – 120)
M2	E	0.80	0,012	0,016	0,020	0,024	0,032	0,040	0,048	0,065	0,080	0,10	80 (70 – 100)
M3	E	0.60	0,0095	0,012	0,015	0,019	0,025	0,030	0,038	0,050	0,060	0,075	55 (40 – 70)
M4	E	0.60	0,0095	0,012	0,015	0,019	0,025	0,030	0,038	0,050	0,060	0,075	40 (30 – 50)
M5	E	0.60	0,0095	0,012	0,015	0,019	0,025	0,030	0,038	0,050	0,060	0,075	33 (25 – 40)
S1	E	0.30	0,0095	0,012	0,015	0,019	0,025	0,030	0,038	0,050	0,060	0,075	41 (20 – 55)
S2	E	0.30	0,0095	0,012	0,015	0,019	0,025	0,030	0,038	0,050	0,060	0,075	33 (15 – 45)
S3	E	0.30	0,0095	0,012	0,015	0,019	0,025	0,030	0,038	0,050	0,060	0,075	28 (15 – 40)
S11	E	0.50	0,012	0,016	0,020	0,025	0,032	0,042	0,050	0,065	0,080	0,10	95 (65 – 125)
S12	E	0.50	0,012	0,016	0,020	0,025	0,032	0,042	0,050	0,065	0,080	0,10	70 (50 – 95)
S13	E	0.50	0,012	0,016	0,020	0,025	0,032	0,042	0,050	0,065	0,080	0,10	55 (35 – 75)

If radius exceeds 15% of value DC please reduce fz with 20%

For cutting data recalculations, see page 411-418.

SMG = Seco material group

Coolant = A=air D=dry E=emulsion M=mist spray

v_c = m/min

f_z = mm

a_p (mm)/DC (mm) = factor

a_s (mm)/DC (mm) = factor

All cutting data are target values

Cutting data – JS754_2C Advanced roughing $a_p/DC=0,05-0,1$

SMG		a_p/DC	a_p/DC	f_z		 v_c
				10	12	
P11	M/A/D/E	0,10	2,0	0,15	0,17	265 (215 – 295)
P12	M/A/D/E	0,10	2,0	0,10	0,12	170 (140 – 190)
M1	E	0,10	2,0	0,11	0,13	205 (170 – 230)
M2	E	0,10	2,0	0,10	0,12	170 (140 – 190)
M3	E	0,10	2,0	0,10	0,12	130 (110 – 150)
M4	E	0,10	2,0	0,085	0,10	100 (85 – 115)
M5	E	0,10	2,0	0,085	0,10	85 (70 – 95)
S1	E	0,050	2,0	0,085	0,10	70 (45 – 100)
S2	E	0,050	2,0	0,085	0,10	60 (35 – 80)
S3	E	0,050	2,0	0,080	0,095	50 (30 – 70)
S11	E	0,080	2,0	0,070	0,085	165 (140 – 195)
S12	E	0,080	2,0	0,070	0,085	125 (105 – 150)
S13	E	0,080	2,0	0,060	0,070	100 (85 – 120)

Cutting data – JS754_3C Advanced roughing $a_p/DC=0,05-0,1$

SMG		a_p/DC	a_p/DC	f_z						 v_c
				6	8	10	12	16	20	
P11	M/A/D/E	0,10	4,0	0,090	0,12	0,15	0,17	0,22	0,25	265 (215 – 290)
P12	M/A/D/E	0,10	4,0	0,060	0,080	0,10	0,12	0,15	0,17	170 (140 – 190)
M1	E	0,10	4,0	0,065	0,090	0,11	0,13	0,16	0,19	205 (170 – 230)
M2	E	0,10	4,0	0,060	0,080	0,10	0,12	0,15	0,17	170 (140 – 190)
M3	E	0,10	4,0	0,060	0,080	0,10	0,12	0,15	0,17	130 (110 – 150)
M4	E	0,10	4,0	0,050	0,070	0,085	0,10	0,13	0,15	100 (85 – 115)
M5	E	0,10	4,0	0,050	0,070	0,085	0,10	0,13	0,15	85 (70 – 95)
S1	E	0,050	4,0	0,050	0,070	0,085	0,10	0,13	0,15	70 (45 – 100)
S2	E	0,050	4,0	0,050	0,070	0,085	0,10	0,13	0,15	55 (35 – 80)
S3	E	0,050	4,0	0,048	0,065	0,080	0,095	0,12	0,14	50 (30 – 70)
S11	E	0,080	4,0	0,042	0,055	0,070	0,085	0,10	0,12	165 (135 – 195)
S12	E	0,080	4,0	0,042	0,055	0,070	0,085	0,10	0,12	125 (105 – 150)
S13	E	0,080	4,0	0,036	0,048	0,060	0,070	0,090	0,10	100 (85 – 120)

If radius exceeds 15% of value DC please reduce fz with 20%

For cutting data recalculations, see page 411-418.

SMG = Seco material group

Coolant = A=air D=dry E=emulsion M=mist spray

v_c = m/min

f_z = mm

a_p (mm)/DC (mm)= factor

a_g (mm)/DC (mm)= factor

All cutting data are target values

JS755 – High performance – Square – ISO-M and ISO-S – 5 Flutes – Weldon – Corner radius



Tolerances:
 DMM= h5
 DC= e7
 RE= ±0,01 mm
 Regrind possible if DC is ≥Ø6

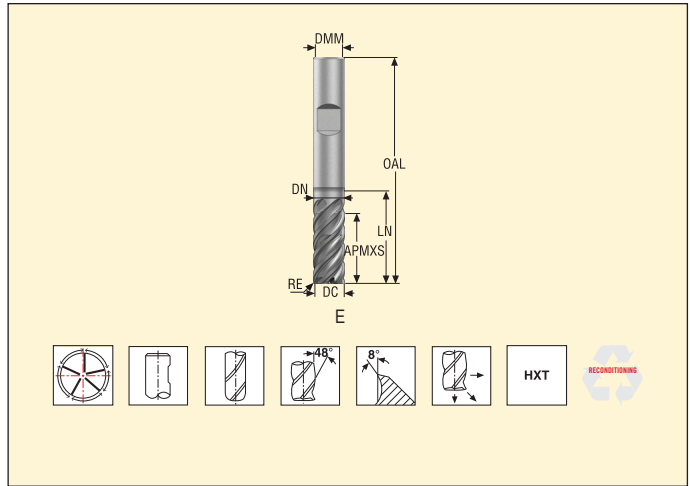

Ordering and Product No.	Designation	Length index	Tool shape	Dimensions in mm							PCEDC	Weldon
				DC	DMM	APMXS	OAL	LN	DN	RE		
03187101	JS755060E2R020.3Z5-HXT	2	E	6,0	6	12,0	57	18,0	5,7	0,2	5	■
03187102	JS755060E2R050.3Z5-HXT	2	E	6,0	6	12,0	57	18,0	5,7	0,5	5	■
03187103	JS755060E2R100.3Z5-HXT	2	E	6,0	6	12,0	57	18,0	5,7	1,0	5	■
03187104	JS755080E2R050.3Z5-HXT	2	E	8,0	8	16,0	63	25,0	7,6	0,5	5	■
03187105	JS755080E2R100.3Z5-HXT	2	E	8,0	8	16,0	63	25,0	7,6	1,0	5	■
03187106	JS755100E2R050.3Z5-HXT	2	E	10,0	10	20,0	72	29,0	9,5	0,5	5	■
03187107	JS755100E2R100.3Z5-HXT	2	E	10,0	10	20,0	72	29,0	9,5	1,0	5	■
03187108	JS755100E2R200.3Z5-HXT	2	E	10,0	10	20,0	72	29,0	9,5	2,0	5	■
03187109	JS755100E2R300.3Z5-HXT	2	E	10,0	10	20,0	72	29,0	9,5	3,0	5	■
03187110	JS755120E2R050.3Z5-HXT	2	E	12,0	12	24,0	83	35,0	11,4	0,5	5	■
03187111	JS755120E2R100.3Z5-HXT	2	E	12,0	12	24,0	83	35,0	11,4	1,0	5	■
03187112	JS755120E2R200.3Z5-HXT	2	E	12,0	12	24,0	83	35,0	11,4	2,0	5	■
03187113	JS755120E2R300.3Z5-HXT	2	E	12,0	12	24,0	83	35,0	11,4	3,0	5	■
03187114	JS755160E2R050.3Z5-HXT	2	E	16,0	16	32,0	92	42,0	15,2	0,5	5	■
03187115	JS755160E2R100.3Z5-HXT	2	E	16,0	16	32,0	92	42,0	15,2	1,0	5	■
03187116	JS755160E2R600.3Z5-HXT	2	E	16,0	16	32,0	92	42,0	15,2	6,0	5	■
03187117	JS755200E2R050.3Z5-HXT	2	E	20,0	20	40,0	104	51,0	19,0	0,5	5	■
03187118	JS755200E2R100.3Z5-HXT	2	E	20,0	20	40,0	104	51,0	19,0	1,0	5	■
03187119	JS755200E2R600.3Z5-HXT	2	E	20,0	20	40,0	104	51,0	19,0	6,0	5	■
03187122	JS755060E3R020.3Z5-HXT	3	E	6,0	6	21,0	65	26,0	5,7	0,2	5	□
03187123	JS755060E3R050.3Z5-HXT	3	E	6,0	6	21,0	65	26,0	5,7	0,5	5	□
03187124	JS755060E3R100.3Z5-HXT	3	E	6,0	6	21,0	65	26,0	5,7	1,0	5	□
03187125	JS755080E3R050.3Z5-HXT	3	E	8,0	8	32,0	75	37,0	7,6	0,5	5	□
03187126	JS755080E3R100.3Z5-HXT	3	E	8,0	8	32,0	75	37,0	7,6	1,0	5	□
03187127	JS755100E3R050.3Z5-HXT	3	E	10,0	10	40,0	89	47,0	9,5	0,5	5	□
03187128	JS755100E3R100.3Z5-HXT	3	E	10,0	10	40,0	89	47,0	9,5	1,0	5	□
03187129	JS755100E3R200.3Z5-HXT	3	E	10,0	10	40,0	89	47,0	9,5	2,0	5	□
03187130	JS755100E3R300.3Z5-HXT	3	E	10,0	10	40,0	89	47,0	9,5	3,0	5	□
03187131	JS755120E3R050.3Z5-HXT	3	E	12,0	12	45,0	100	53,0	11,4	0,5	5	□
03187132	JS755120E3R100.3Z5-HXT	3	E	12,0	12	45,0	100	53,0	11,4	1,0	5	□
03187133	JS755120E3R200.3Z5-HXT	3	E	12,0	12	45,0	100	53,0	11,4	2,0	5	□
03187134	JS755120E3R300.3Z5-HXT	3	E	12,0	12	45,0	100	53,0	11,4	3,0	5	□
03187135	JS755160E3R050.3Z5-HXT	3	E	16,0	16	55,0	115	65,0	15,2	0,5	5	□
03187136	JS755160E3R600.3Z5-HXT	3	E	16,0	16	55,0	115	65,0	15,2	6,0	5	□
03187137	JS755200E3R050.3Z5-HXT	3	E	20,0	20	61,0	125	72,0	19,0	0,5	5	□
03187138	JS755200E3R600.3Z5-HXT	3	E	20,0	20	61,0	125	72,0	19,0	6,0	5	□

■ Stock standard. Subject to change refer to current price- and stock-list □ Weldon available, delivery time is 3 days.

JS755 – High performance – Square – ISO– M and ISO– S – 5 Flutes – Safelock – Chamfer – Corner radius



Tolerances:
 DMM= h5
 DC= e7
 RE= ±0,01 mm
 Regrind possible if DC is ≥Ø6

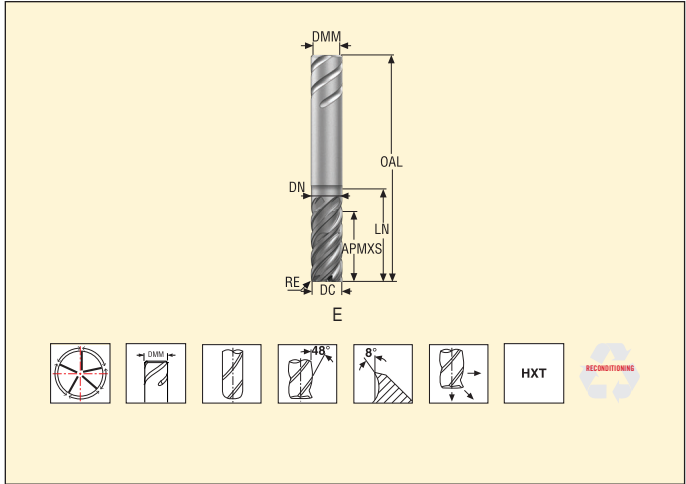

Ordering and Product No.	Designation	Length index	Tool shape	Dimensions in mm							PCEDC	Safelock
				DC	DMM	APMXS	OAL	LN	DN	RE		
03187254	JS755060E2R020.9Z5-HXT	2	E	6,0	6	12,0	57	18,0	5,7	0,2	5	<input type="checkbox"/>
03187255	JS755060E2R050.9Z5-HXT	2	E	6,0	6	12,0	57	18,0	5,7	0,5	5	<input type="checkbox"/>
03187256	JS755060E2R100.9Z5-HXT	2	E	6,0	6	12,0	57	18,0	5,7	1,0	5	<input type="checkbox"/>
03187257	JS755080E2R050.9Z5-HXT	2	E	8,0	8	16,0	63	25,0	7,6	0,5	5	<input type="checkbox"/>
03187258	JS755080E2R100.9Z5-HXT	2	E	8,0	8	16,0	63	25,0	7,6	1,0	5	<input type="checkbox"/>
03187259	JS755100E2R050.9Z5-HXT	2	E	10,0	10	20,0	72	29,0	9,5	0,5	5	<input type="checkbox"/>
03187260	JS755100E2R100.9Z5-HXT	2	E	10,0	10	20,0	72	29,0	9,5	1,0	5	<input type="checkbox"/>
03187261	JS755100E2R200.9Z5-HXT	2	E	10,0	10	20,0	72	29,0	9,5	2,0	5	<input type="checkbox"/>
03187262	JS755100E2R300.9Z5-HXT	2	E	10,0	10	20,0	72	29,0	9,5	3,0	5	<input type="checkbox"/>
03187263	JS755120E2R050.9Z5-HXT	2	E	12,0	12	24,0	83	35,0	11,4	0,5	5	<input type="checkbox"/>
03187264	JS755120E2R100.9Z5-HXT	2	E	12,0	12	24,0	83	35,0	11,4	1,0	5	<input type="checkbox"/>
03187265	JS755120E2R200.9Z5-HXT	2	E	12,0	12	24,0	83	35,0	11,4	2,0	5	<input type="checkbox"/>
03187266	JS755120E2R300.9Z5-HXT	2	E	12,0	12	24,0	83	35,0	11,4	3,0	5	<input type="checkbox"/>
03187267	JS755160E2R050.9Z5-HXT	2	E	16,0	16	32,0	92	42,0	15,2	0,5	5	<input type="checkbox"/>
03187269	JS755160E2R100.9Z5-HXT	2	E	16,0	16	32,0	92	42,0	15,2	1,0	5	<input type="checkbox"/>
03187270	JS755160E2R600.9Z5-HXT	2	E	16,0	16	32,0	92	42,0	15,2	6,0	5	<input type="checkbox"/>
03187271	JS755200E2R050.9Z5-HXT	2	E	20,0	20	40,0	104	51,0	19,0	0,5	5	<input type="checkbox"/>
03187272	JS755200E2R100.9Z5-HXT	2	E	20,0	20	40,0	104	51,0	19,0	1,0	5	<input type="checkbox"/>
03187273	JS755200E2R600.9Z5-HXT	2	E	20,0	20	40,0	104	51,0	19,0	6,0	5	<input type="checkbox"/>
03187276	JS755060E3R020.9Z5-HXT	3	E	6,0	6	21,0	65	26,0	5,7	0,2	5	<input type="checkbox"/>
03187277	JS755060E3R050.9Z5-HXT	3	E	6,0	6	21,0	65	26,0	5,7	0,5	5	<input type="checkbox"/>
03187279	JS755060E3R100.9Z5-HXT	3	E	6,0	6	21,0	65	26,0	5,7	1,0	5	<input type="checkbox"/>
03187280	JS755080E3R050.9Z5-HXT	3	E	8,0	8	32,0	75	37,0	7,6	0,5	5	<input type="checkbox"/>
03187281	JS755080E3R100.9Z5-HXT	3	E	8,0	8	32,0	75	37,0	7,6	1,0	5	<input type="checkbox"/>
03187282	JS755100E3R050.9Z5-HXT	3	E	10,0	10	40,0	89	47,0	9,5	0,5	5	<input type="checkbox"/>
03187283	JS755100E3R100.9Z5-HXT	3	E	10,0	10	40,0	89	47,0	9,5	1,0	5	<input type="checkbox"/>
03187284	JS755100E3R200.9Z5-HXT	3	E	10,0	10	40,0	89	47,0	9,5	2,0	5	<input type="checkbox"/>
03187285	JS755100E3R300.9Z5-HXT	3	E	10,0	10	40,0	89	47,0	9,5	3,0	5	<input type="checkbox"/>
03187286	JS755120E3R050.9Z5-HXT	3	E	12,0	12	45,0	100	53,0	11,4	0,5	5	<input type="checkbox"/>
03187287	JS755120E3R100.9Z5-HXT	3	E	12,0	12	45,0	100	53,0	11,4	1,0	5	<input type="checkbox"/>
03187288	JS755120E3R200.9Z5-HXT	3	E	12,0	12	45,0	100	53,0	11,4	2,0	5	<input type="checkbox"/>
03187289	JS755120E3R300.9Z5-HXT	3	E	12,0	12	45,0	100	53,0	11,4	3,0	5	<input type="checkbox"/>
03187290	JS755160E3R050.9Z5-HXT	3	E	16,0	16	55,0	115	65,0	15,2	0,5	5	<input type="checkbox"/>
03187291	JS755160E3R600.9Z5-HXT	3	E	16,0	16	55,0	115	65,0	15,2	6,0	5	<input type="checkbox"/>
03187292	JS755200E3R050.9Z5-HXT	3	E	20,0	20	61,0	125	72,0	19,0	0,5	5	<input type="checkbox"/>
03187293	JS755200E3R600.9Z5-HXT	3	E	20,0	20	61,0	125	72,0	19,0	6,0	5	<input type="checkbox"/>

Safelock available. Subject to change, refer to current Price and Stock List.

Cutting data – JS755 Side milling roughing

SMG		a _e /DC	a _p /DC	f _z							
				6	8	10	12	16	20	25	
P11	M/A/D/E	0,40	1,3	0,044	0,060	0,075	0,085	0,11	0,12	0,14	135 (95 – 155)
P12	M/A/D/E	0,40	1,1	0,030	0,040	0,050	0,060	0,075	0,085	0,095	85 (60 – 100)
M1	E	0,40	1,1	0,032	0,044	0,055	0,065	0,080	0,095	0,11	170 (140 – 190)
M2	E	0,40	1,1	0,030	0,040	0,050	0,060	0,075	0,085	0,095	140 (120 – 155)
M3	E	0,40	1,1	0,030	0,040	0,050	0,060	0,075	0,085	0,095	110 (90 – 125)
M4	E	0,40	0,80	0,026	0,034	0,044	0,050	0,065	0,075	0,085	85 (70 – 95)
M5	E	0,40	0,80	0,026	0,034	0,044	0,050	0,065	0,075	0,085	70 (60 – 80)
S1	E	0,030	2,0	0,046	0,060	0,075	0,090	0,11	0,13	0,14	70 (50 – 110)
S2	E	0,030	2,0	0,046	0,060	0,075	0,090	0,11	0,13	0,14	60 (40 – 90)
S3	E	0,030	2,0	0,042	0,055	0,070	0,085	0,10	0,12	0,13	50 (35 – 80)
S11	E	0,40	1,1	0,030	0,040	0,050	0,060	0,075	0,085	0,095	140 (120 – 170)
S12	E	0,40	1,1	0,030	0,040	0,050	0,060	0,075	0,085	0,095	110 (90 – 130)
S13	E	0,40	0,90	0,026	0,034	0,044	0,050	0,065	0,075	0,085	85 (70 – 100)

Cutting data – JS755_3C Advanced roughing a_e/DC=0,05-0,1

SMG		a _e /DC	a _p /DC	f _z				
				10	12	16	20	
P11	M/A/D/E	0,10	4,0	0,15	0,17	0,22	0,25	265 (220 – 290)
P12	M/A/D/E	0,10	4,0	0,10	0,12	0,15	0,17	170 (140 – 180)
M1	E	0,10	4,0	0,11	0,13	0,16	0,19	205 (170 – 220)
M2	E	0,10	4,0	0,10	0,12	0,15	0,17	170 (140 – 180)
M3	E	0,10	4,0	0,10	0,12	0,15	0,17	130 (110 – 140)
M4	E	0,10	4,0	0,085	0,10	0,13	0,15	100 (85 – 110)
M5	E	0,10	4,0	0,085	0,10	0,13	0,15	85 (71 – 96)
S1	E	0,050	4,0	0,085	0,10	0,13	0,15	70 (45-100)
S2	E	0,050	4,0	0,085	0,10	0,13	0,15	55 (35 – 80)
S3	E	0,050	4,0	0,085	0,10	0,13	0,15	50 (30-70)
S11	E	0,080	4,0	0,070	0,085	0,10	0,12	160 (140 – 190)
S12	E	0,080	4,0	0,070	0,085	0,10	0,12	125 (110 – 140)
S13	E	0,080	4,0	0,060	0,070	0,090	0,10	100 (83 – 110)

If radius exceeds 15% of value DC please reduce fz with 20%

For cutting data recalculations, see page 411-418.

SMG = Seco material group

Coolant = A=air D=dry E=emulsion M=mist spray

v_c = m/min

f_z = mm

a_p (mm)/DC (mm)= factor

a_e (mm)/DC (mm)= factor

All cutting data are target values

JS720 – High performance – Titanium – Square – 6 Flutes – Cylindrical – Corner radius



Tolerances:
 DMM= h5
 DC= e7
 RE= ±0,02 mm
 Regrind possible if DC is ≥Ø6

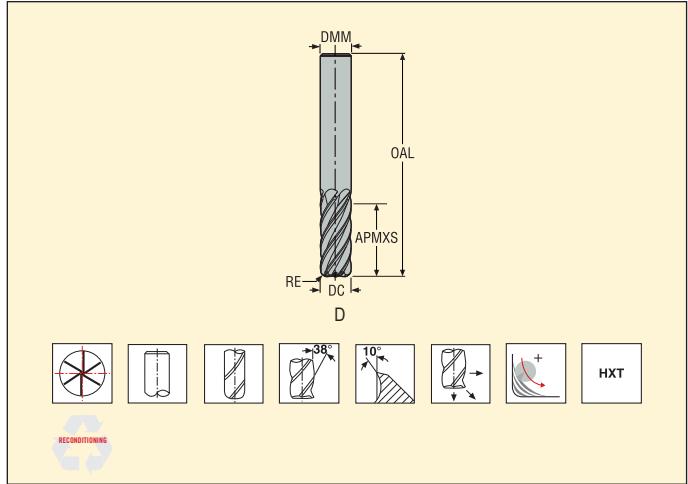

Ordering and Product No.	Designation	Length index	Tool shape	Dimensions in mm				RE	PCEDC	Cylindrical
				DC	DMM	APMXS	OAL			
03060293	JS720060D2R050.0Z6-HXT	2	D	6,0	6	17	57	0,5	6	■
03060294	JS720060D2R100.0Z6-HXT	2	D	6,0	6	17	57	1,0	6	■
03060295	JS720080D2R050.0Z6-HXT	2	D	8,0	8	23	63	0,5	6	■
03061294	JS720080D2R100.0Z6-HXT	2	D	8,0	8	23	63	1,0	6	■
03060296	JS720100D2R050.0Z6-HXT	2	D	10,0	10	26	72	0,5	6	■
03060298	JS720100D2R100.0Z6-HXT	2	D	10,0	10	26	72	1,0	6	■
03060299	JS720100D2R200.0Z6-HXT	2	D	10,0	10	26	72	2,0	6	■
03060300	JS720100D2R300.0Z6-HXT	2	D	10,0	10	26	72	3,0	6	■
03060301	JS720120D2R050.0Z6-HXT	2	D	12,0	12	30	83	0,5	6	■
03060304	JS720120D2R100.0Z6-HXT	2	D	12,0	12	30	83	1,0	6	■
03060305	JS720120D2R200.0Z6-HXT	2	D	12,0	12	30	83	2,0	6	■
03060306	JS720120D2R300.0Z6-HXT	2	D	12,0	12	30	83	3,0	6	■
03060307	JS720160D2R050.0Z6-HXT	2	D	16,0	16	44	99	0,5	6	■
03060309	JS720160D2R100.0Z6-HXT	2	D	16,0	16	44	99	1,0	6	■
03060310	JS720160D2R200.0Z6-HXT	2	D	16,0	16	44	99	2,0	6	■
03060311	JS720160D2R300.0Z6-HXT	2	D	16,0	16	44	99	3,0	6	■
03060312	JS720160D2R400.0Z6-HXT	2	D	16,0	16	44	99	4,0	6	■
03060313	JS720160D2R600.0Z6-HXT	2	D	16,0	16	44	99	6,0	6	■
03169498	JS720250D2R300.0Z6-HXT	2	D	25,0	25	50	125	3,0	6	■
03169497	JS720160D3R300.0Z6-HXT	3	D	16,0	16	65	130	3,0	6	■
03060314	JS720200D3R050.0Z6-HXT	3	D	20,0	20	62	121	0,5	6	■
03060316	JS720200D3R100.0Z6-HXT	3	D	20,0	20	62	121	1,0	6	■
03060317	JS720200D3R200.0Z6-HXT	3	D	20,0	20	62	121	2,0	6	■
03060318	JS720200D3R300.0Z6-HXT	3	D	20,0	20	62	121	3,0	6	■
03060319	JS720200D3R400.0Z6-HXT	3	D	20,0	20	62	121	4,0	6	■
03060320	JS720200D3R500.0Z6-HXT	3	D	20,0	20	62	121	5,0	6	■
03060321	JS720200D3R600.0Z6-HXT	3	D	20,0	20	62	121	6,0	6	■
03060322	JS720250D3R050.0Z6-HXT	3	D	25,0	25	78	146	0,5	6	■
03060323	JS720250D3R100.0Z6-HXT	3	D	25,0	25	78	146	1,0	6	■
03060324	JS720250D3R200.0Z6-HXT	3	D	25,0	25	78	146	2,0	6	■
03060325	JS720250D3R300.0Z6-HXT	3	D	25,0	25	78	146	3,0	6	■
03060326	JS720250D3R400.0Z6-HXT	3	D	25,0	25	78	146	4,0	6	■
03060327	JS720250D3R600.0Z6-HXT	3	D	25,0	25	78	146	6,0	6	■

■ Stock standard. Subject to change refer to current price- and stock-list

JS720 – High performance – Titanium – Square – 6 Flutes – Weldon – Corner radius



Tolerances:
 DMM= h5
 DC= e7
 RE= ±0,02 mm
 Regrind possible if DC is ≥Ø6

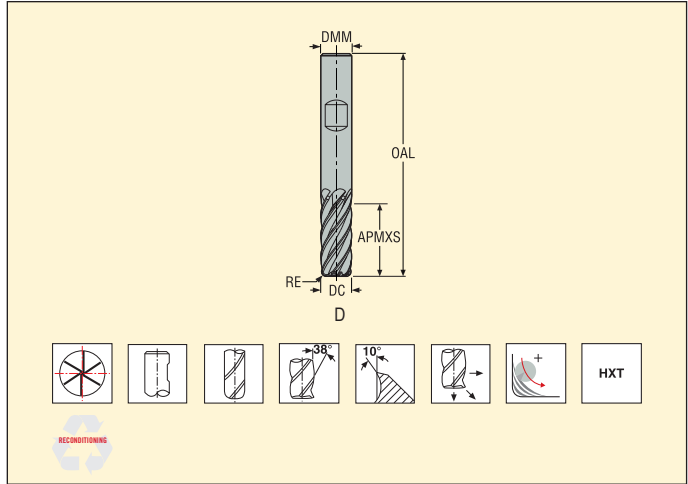

Ordering and Product No.	Designation	Length index	Tool shape	Dimensions in mm				RE	PCEDC	Weldon
				DC	DMM	APMXS	OAL			
03060339	JS720060D2R050.3Z6-HXT	2	D	6,0	6	17	57	0,5	6	<input type="checkbox"/>
03060340	JS720060D2R100.3Z6-HXT	2	D	6,0	6	17	57	1,0	6	<input type="checkbox"/>
03060341	JS720080D2R050.3Z6-HXT	2	D	8,0	8	23	63	0,5	6	<input type="checkbox"/>
03061295	JS720080D2R100.3Z6-HXT	2	D	8,0	8	23	63	1,0	6	<input type="checkbox"/>
03060342	JS720100D2R050.3Z6-HXT	2	D	10,0	10	26	72	0,5	6	<input type="checkbox"/>
03060344	JS720100D2R100.3Z6-HXT	2	D	10,0	10	26	72	1,0	6	<input type="checkbox"/>
03060345	JS720100D2R200.3Z6-HXT	2	D	10,0	10	26	72	2,0	6	<input type="checkbox"/>
03060346	JS720100D2R300.3Z6-HXT	2	D	10,0	10	26	72	3,0	6	<input type="checkbox"/>
03060347	JS720120D2R050.3Z6-HXT	2	D	12,0	12	30	83	0,5	6	<input type="checkbox"/>
03060349	JS720120D2R100.3Z6-HXT	2	D	12,0	12	30	83	1,0	6	<input type="checkbox"/>
03060350	JS720120D2R200.3Z6-HXT	2	D	12,0	12	30	83	2,0	6	<input type="checkbox"/>
03060351	JS720120D2R300.3Z6-HXT	2	D	12,0	12	30	83	3,0	6	<input type="checkbox"/>
03060352	JS720160D2R050.3Z6-HXT	2	D	16,0	16	44	99	0,5	6	<input type="checkbox"/>
03060354	JS720160D2R100.3Z6-HXT	2	D	16,0	16	44	99	1,0	6	<input type="checkbox"/>
03060355	JS720160D2R200.3Z6-HXT	2	D	16,0	16	44	99	2,0	6	<input type="checkbox"/>
03060356	JS720160D2R300.3Z6-HXT	2	D	16,0	16	44	99	3,0	6	<input type="checkbox"/>
03060357	JS720160D2R400.3Z6-HXT	2	D	16,0	16	44	99	4,0	6	<input type="checkbox"/>
03060358	JS720160D2R600.3Z6-HXT	2	D	16,0	16	44	99	6,0	6	<input type="checkbox"/>
03060359	JS720200D3R050.3Z6-HXT	3	D	20,0	20	62	121	0,5	6	<input type="checkbox"/>
03060361	JS720200D3R100.3Z6-HXT	3	D	20,0	20	62	121	1,0	6	<input type="checkbox"/>
03060362	JS720200D3R200.3Z6-HXT	3	D	20,0	20	62	121	2,0	6	<input type="checkbox"/>
03060363	JS720200D3R300.3Z6-HXT	3	D	20,0	20	62	121	3,0	6	<input checked="" type="checkbox"/>
03060364	JS720200D3R400.3Z6-HXT	3	D	20,0	20	62	121	4,0	6	<input type="checkbox"/>
03060365	JS720200D3R500.3Z6-HXT	3	D	20,0	20	62	121	5,0	6	<input type="checkbox"/>
03060366	JS720200D3R600.3Z6-HXT	3	D	20,0	20	62	121	6,0	6	<input type="checkbox"/>
03060367	JS720250D3R050.3Z6-HXT	3	D	25,0	25	78	146	0,5	6	<input type="checkbox"/>
03060368	JS720250D3R100.3Z6-HXT	3	D	25,0	25	78	146	1,0	6	<input type="checkbox"/>
03060369	JS720250D3R200.3Z6-HXT	3	D	25,0	25	78	146	2,0	6	<input type="checkbox"/>
03060370	JS720250D3R300.3Z6-HXT	3	D	25,0	25	78	146	3,0	6	<input type="checkbox"/>
03060371	JS720250D3R400.3Z6-HXT	3	D	25,0	25	78	146	4,0	6	<input checked="" type="checkbox"/>
03060372	JS720250D3R600.3Z6-HXT	3	D	25,0	25	78	146	6,0	6	<input type="checkbox"/>

■ Stock standard. Subject to change refer to current price- and stock-list Weldon available, delivery time is 3 days.

Cutting data – JS720 Side milling

SMG		a _e /DC	a _p /DC	f _z							
				6	8	10	12	16	20	25	
M1	E	0,40	1,1	0,030	0,040	0,050	0,060	0,075	0,085	0,095	110 (85 – 150)
M2	E	0,40	1,1	0,028	0,036	0,046	0,055	0,065	0,075	0,085	90 (70 – 120)
M3	E	0,40	1,1	0,030	0,040	0,050	0,060	0,075	0,085	0,095	70 (55 – 100)
M4	E	0,40	1,1	0,030	0,040	0,050	0,060	0,075	0,085	0,095	80 (60 – 100)
M5	E	0,40	1,1	0,030	0,040	0,050	0,060	0,075	0,085	0,095	65 (50 – 85)
S11	E	0,40	1,1	0,030	0,040	0,050	0,060	0,075	0,085	0,095	105 (80 – 130)
S12	E	0,40	1,1	0,030	0,040	0,050	0,060	0,075	0,085	0,095	80 (60 – 100)
S13	E	0,40	1,1	0,030	0,040	0,050	0,060	0,075	0,085	0,095	80 (60 – 100)

Cutting data – JS720 Side milling advanced roughing a_e/DC=0,07

SMG		a _p /DC	f _z							
			6	8	10	12	16	20	25	
M1	E	1,9	0,060	0,080	0,095	0,12	0,14	0,16	0,19	145 (110 – 190)
M2	E	1,9	0,055	0,070	0,090	0,10	0,13	0,15	0,17	120 (90 – 155)
M3	E	1,9	0,060	0,080	0,095	0,12	0,14	0,16	0,19	90 (70 – 130)
M4	E	1,9	0,060	0,080	0,095	0,12	0,14	0,16	0,19	105 (80 – 130)
M5	E	1,9	0,060	0,080	0,095	0,12	0,14	0,16	0,19	85 (65 – 110)
S11	E	1,9	0,060	0,080	0,095	0,12	0,14	0,16	0,19	135 (100 – 170)
S12	E	1,9	0,060	0,080	0,095	0,12	0,14	0,16	0,19	105 (80 – 130)
S13	E	1,9	0,060	0,080	0,095	0,12	0,14	0,16	0,19	105 (80 – 130)

For cutting data recalculations, see page 411-418.

SMG = Seco material group

Coolant = A=air D=dry E=emulsion M=mist spray

v_c = m/min

f_z = mm

a_p (mm)/DC (mm)= factor

a_e (mm)/DC (mm)= factor

All cutting data are target values

Cutting data – JS730 Side milling roughing

SMG		a _e /DC	a _p /DC	f _z							v _c
				6	8	10	12	16	20	25	
M1	E	0,10	1,8	0,048	0,065	0,080	0,095	0,12	0,14	0,15	135 (85 – 150)
M2	E	0,10	1,8	0,044	0,060	0,075	0,085	0,11	0,12	0,14	110 (70 – 120)
M3	E	0,10	1,8	0,048	0,065	0,080	0,095	0,12	0,14	0,15	85 (55 – 100)
M4	E	0,10	1,3	0,044	0,060	0,070	0,085	0,11	0,12	0,14	90 (60 – 105)
M5	E	0,10	1,3	0,044	0,060	0,070	0,085	0,11	0,12	0,14	75 (48 – 90)
S11	E	0,30	1,2	0,030	0,040	0,050	0,060	0,075	0,085	0,095	130 (80 – 130)
S12	E	0,30	1,2	0,030	0,040	0,050	0,060	0,075	0,085	0,095	100 (60 – 100)
S13	E	0,30	1,0	0,028	0,036	0,046	0,055	0,065	0,075	0,085	100 (60 – 105)

Cutting data – JS730 Side milling advanced roughing a_e/DC=0,07

SMG		a _p /DC	f _z							v _c
			6	8	10	12	16	20	25	
M1	E	1,9	0,055	0,075	0,095	0,11	0,14	0,16	0,18	145 (90 – 155)
M2	E	1,9	0,050	0,070	0,085	0,10	0,13	0,14	0,16	120 (75 – 125)
M3	E	1,9	0,055	0,075	0,095	0,11	0,14	0,16	0,18	90 (55 – 105)
M4	E	1,4	0,050	0,070	0,085	0,10	0,12	0,14	0,16	95 (60 – 110)
M5	E	1,4	0,050	0,070	0,085	0,10	0,12	0,14	0,16	80 (50 – 90)
S11	E	1,9	0,050	0,070	0,085	0,10	0,13	0,15	0,17	150 (95 – 155)
S12	E	1,9	0,050	0,070	0,085	0,10	0,13	0,15	0,17	115 (70 – 120)
S13	E	1,7	0,046	0,060	0,075	0,090	0,11	0,13	0,15	120 (75 – 125)

For cutting data recalculations, see page 411-418.

SMG = Seco material group

Coolant = A=air D=dry E=emulsion M=mist spray

v_c = m/min

f_z = mm

a_p (mm)/DC (mm)= factor

a_e (mm)/DC (mm)= factor

All cutting data are target values

JHP750 – High performance – Titanium – Square – 2-4 Flutes – Cylindrical – Corner radius



Tolerances:
 DMM=h5
 DC=-0,02/-0,04 mm
 RE= ±0,02 mm
 Regrind possible if DC is ≥Ø6

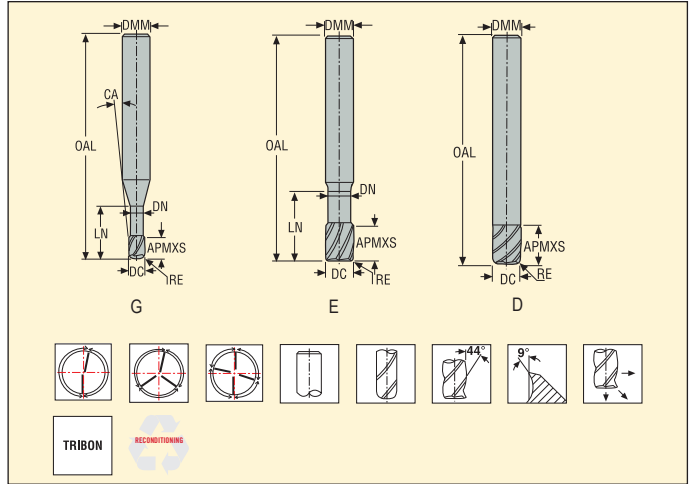

Ordering and Product No.	Designation	Length index	Tool shape	Dimensions in mm								RE	CA	PCE/DC	Cylindrical
				DC	DMM	APMXS	OAL	LN	DN	RE	CA				
02528232	750K080R040.0-TRIBON	1	D	8,0	8	16,0	55	-	-	0,4	-	4	■		
02528234	750K100R040.0-TRIBON	1	D	10,0	10	20,0	65	-	-	0,4	-	4	■		
02528236	750K100R150.0-TRIBON	1	D	10,0	10	20,0	65	-	-	1,5	-	4	■		
02528238	750K120R040.0-TRIBON	1	D	12,0	12	24,0	75	-	-	0,4	-	4	■		
02528242	750K120R150.0-TRIBON	1	D	12,0	12	24,0	75	-	-	1,5	-	4	■		
02528244	750K160R040.0-TRIBON	1	D	16,0	16	32,0	90	-	-	0,4	-	4	■		
02528250	750K160R150.0-TRIBON	1	D	16,0	16	32,0	90	-	-	1,5	-	4	■		
02528253	750K200R080.0-TRIBON	1	D	20,0	20	40,0	100	-	-	0,8	-	4	■		
02510010	750020R020.0-TRIBON	2	G	2,0	3	3,0	40	6	1,9	0,2	4,0	2	■		
02510012	750030R020.0-TRIBON	2	E	3,0	3	4,5	40	9	2,8	0,2	-	2	■		
02510013	750040R020.0-TRIBON	2	G	4,0	6	6,0	40	9	3,7	0,2	5,0	2	■		
02510043	750050R030.0-TRIBON	2	G	5,0	6	7,5	40	9	4,6	0,3	3,0	2	■		
02510044	750060R030.0-TRIBON	2	E	6,0	6	9,0	50	19	5,6	0,3	-	3	■		
02510045	750080R040.0-TRIBON	2	E	8,0	8	16,0	60	24	7,4	0,4	-	4	■		
02510046	750100R040.0-TRIBON	2	E	10,0	10	20,0	70	30	9,4	0,4	-	4	■		
02510049	750100R080.0-TRIBON	2	E	10,0	10	20,0	70	30	9,4	0,8	-	4	■		
02510053	750100R200.0-TRIBON	2	E	10,0	10	20,0	70	30	9,4	2,0	-	4	■		
02510057	750120R040.0-TRIBON	2	E	12,0	12	24,0	80	35	11,4	0,4	-	4	■		
02510060	750120R080.0-TRIBON	2	E	12,0	12	24,0	80	35	11,4	0,8	-	4	■		
02510063	750120R200.0-TRIBON	2	E	12,0	12	24,0	80	35	11,4	2,0	-	4	■		
02510065	750120R310.0-TRIBON	2	E	12,0	12	24,0	80	35	11,4	3,1	-	4	■		
02510067	750140R080.0-TRIBON	2	E	14,0	14	28,0	90	45	13,4	0,8	-	4	■		
02510071	750160R040.0-TRIBON	2	E	16,0	16	32,0	100	52	15,4	0,4	-	4	■		
02510073	750160R080.0-TRIBON	2	E	16,0	16	32,0	100	52	15,4	0,8	-	4	■		
02510077	750160R200.0-TRIBON	2	E	16,0	16	32,0	100	52	15,4	2,0	-	4	■		
02510079	750160R310.0-TRIBON	2	E	16,0	16	32,0	100	52	15,4	3,1	-	4	■		
02510081	750160R400.0-TRIBON	2	E	16,0	16	32,0	100	52	15,4	4,0	-	4	■		
02510085	750200R080.0-TRIBON	2	E	20,0	20	40,0	125	75	19,4	0,8	-	4	■		
02510087	750200R200.0-TRIBON	2	E	20,0	20	40,0	125	75	19,4	2,0	-	4	■		

■ Stock standard. Subject to change refer to current price- and stock-list

JHP750 – High performance – Titanium – Square – 2-4 Flutes – Weldon – Corner radius



Tolerances:
 DMM=h5
 DC= -0,02/-0,04 mm
 RE= ±0,02 mm
 Regrind possible if DC is ≥Ø6

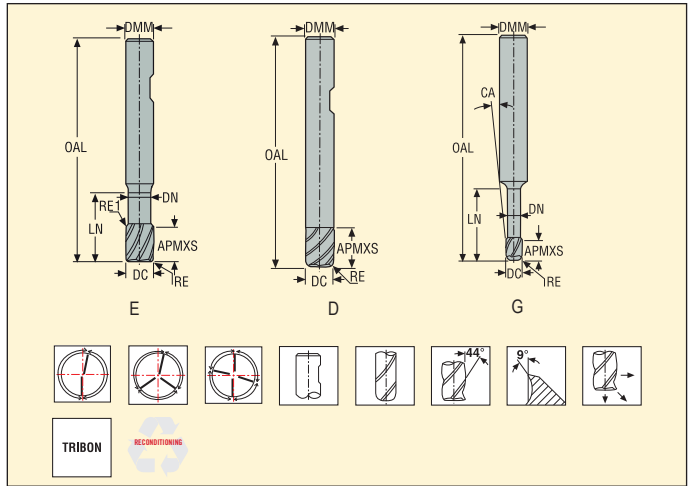

Ordering and Product No.	Designation	Length index	Tool shape	Dimensions in mm							RE	CA	PCEDC	Weldon
				DC	DMM	APMXS	OAL	LN	DN					
02528231	750K080R040-TRIBON	1	D	8,0	8	16	55	-	-	0,4	-	4	■	
02528233	750K100R040-TRIBON	1	D	10,0	10	20	65	-	-	0,4	-	4	■	
02528235	750K100R150-TRIBON	1	D	10,0	10	20	65	-	-	1,5	-	4	■	
02528237	750K120R040-TRIBON	1	D	12,0	12	24	75	-	-	0,4	-	4	■	
02528240	750K120R150-TRIBON	1	D	12,0	12	24	75	-	-	1,5	-	4	■	
02528243	750K160R040-TRIBON	1	D	16,0	16	32	90	-	-	0,4	-	4	■	
02528249	750K160R150-TRIBON	1	D	16,0	16	32	90	-	-	1,5	-	4	■	
02528251	750K200R080-TRIBON	1	D	20,0	20	40	100	-	-	0,8	-	4	■	
02669407	750040R020.0-TRIBONW	2	G	4,0	6	6	40	9	3,7	0,2	5,0	2	□	
02669408	750050R030.0-TRIBONW	2	G	5,0	6	8	40	9	4,6	0,3	3,0	2	□	
02669409	750060R030.0-TRIBONW	2	E	6,0	6	9	50	19	5,6	0,3	-	3	□	
02528258	750080R040-TRIBON	2	E	8,0	8	16	60	24	7,4	0,4	-	4	■	
02510047	750100R040-TRIBON	2	E	10,0	10	20	70	30	9,4	0,4	-	4	■	
02510048	750100R080-TRIBON	2	E	10,0	10	20	70	30	9,4	0,8	-	4	■	
02510052	750100R200-TRIBON	2	E	10,0	10	20	70	30	9,4	2,0	-	4	■	
02510056	750120R040-TRIBON	2	E	12,0	12	24	80	35	11,4	0,4	-	4	■	
02510058	750120R080-TRIBON	2	E	12,0	12	24	80	35	11,4	0,8	-	4	■	
02510062	750120R200-TRIBON	2	E	12,0	12	24	80	35	11,4	2,0	-	4	■	
02510064	750120R310-TRIBON	2	E	12,0	12	24	80	35	11,4	3,1	-	4	■	
02510066	750140R080-TRIBON	2	E	14,0	14	28	90	45	13,4	0,8	-	4	■	
02510070	750160R040-TRIBON	2	E	16,0	16	32	100	52	15,4	0,4	-	4	■	
02510072	750160R080-TRIBON	2	E	16,0	16	32	100	52	15,4	0,8	-	4	■	
02510076	750160R200-TRIBON	2	E	16,0	16	32	100	52	15,4	2,0	-	4	■	
02510078	750160R310-TRIBON	2	E	16,0	16	32	100	52	15,4	3,1	-	4	■	
02510080	750160R400-TRIBON	2	E	16,0	16	32	100	52	15,4	4,0	-	4	■	
02510084	750200R080-TRIBON	2	E	20,0	20	40	125	75	19,4	0,8	-	4	■	
02510086	750200R200-TRIBON	2	E	20,0	20	40	125	75	19,4	2,0	-	4	■	

Remark: if comerradius is >15% of DC then a_p=-30%, f_z=-20%

■ Stock standard. Subject to change refer to current price- and stock-list

Cutting data – JHP750 Slot milling

SMG		a _p /DC	f _z													v _c
			2	3	4	5	6	8	10	12	14	16	18	20	25	
S1	E/M/A	0,45	0,0075	0,011	0,015	0,019	0,022	0,030	0,038	0,044	0,050	0,055	0,060	0,065	0,075	31 (21 – 41)
S2	E/M/A	0,45	0,0075	0,011	0,015	0,019	0,022	0,030	0,038	0,044	0,050	0,055	0,060	0,065	0,075	25 (17 – 33)
S3	E/M/A	0,35	0,0046	0,0070	0,0095	0,012	0,014	0,019	0,024	0,028	0,032	0,034	0,036	0,040	0,044	21 (16 – 31)
S11	E/M/A	0,60	0,0085	0,013	0,017	0,022	0,026	0,034	0,042	0,050	0,055	0,065	0,070	0,075	0,080	95 (80 – 120)
S12	E/M/A	0,60	0,0085	0,013	0,017	0,022	0,026	0,034	0,042	0,050	0,055	0,065	0,070	0,075	0,080	70 (60 – 95)
S13	E/M/A	0,50	0,0075	0,011	0,015	0,019	0,022	0,030	0,038	0,044	0,050	0,055	0,060	0,065	0,070	55 (49 – 75)

Cutting data – JHP750 Side milling

SMG		a _e /DC	a _p /DC	f _z													v _c
				2	3	4	5	6	8	10	12	14	16	15	20	25	
S1	E/M/A	0,060	1,2	0,016	0,024	0,032	0,040	0,048	0,065	0,080	0,095	0,11	0,12	0,13	0,14	0,15	50 (33 – 65)
S2	E/M/A	0,060	1,2	0,016	0,024	0,032	0,040	0,048	0,065	0,080	0,095	0,11	0,12	0,13	0,14	0,15	40 (27 – 55)
S3	E/M/A	0,040	1,2	0,012	0,018	0,024	0,030	0,036	0,048	0,060	0,070	0,080	0,090	0,095	0,10	0,11	35 (26 – 50)
S11	E/M/A	0,080	1,2	0,016	0,024	0,032	0,040	0,048	0,065	0,080	0,095	0,11	0,12	0,13	0,14	0,15	145 (125 – 185)
S12	E/M/A	0,080	1,2	0,016	0,024	0,032	0,040	0,048	0,065	0,080	0,095	0,11	0,12	0,13	0,14	0,15	110 (95 – 145)
S13	E/M/A	0,080	1,2	0,014	0,020	0,028	0,034	0,042	0,055	0,070	0,085	0,095	0,10	0,11	0,12	0,13	90 (75 – 115)

For cutting data recalculations, see page 411-418.

SMG = Seco material group

Coolant = A=air D=dry E=emulsion M=mist spray

v_c = m/min

f_z = mm

a_p (mm)/DC (mm) = factor

a_e (mm)/DC (mm) = factor

All cutting data are target values

JHP760 - High performance - Superalloy - Square - 2-4 Flutes - Cylindrical - Corner radius - ICC



Tolerances:
 DMM=h5
 DC= -0,02/-0,04 mm
 RE= ±0,03 mm
 Regrind possible if DC is ≥Ø6

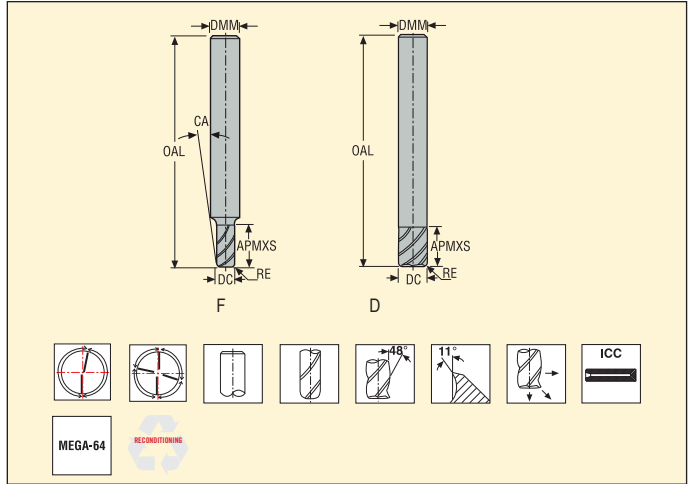

Ordering and Product No.	Designation	Length index	Tool shape	ICC	Dimensions in mm				RE	CA	PCEDC	Cylindrical
					DC	DMM	APMXS	OAL				
02623413	760040R040Z2.0A-MEGA-64	2	F	■	4,0	6	8	50	0,4	4,0	2	■
02734051	760040R020Z2.0A-MEGA-64	2	F	■	4,0	6	8	50	0,2	4,0	2	■
02734052	760050R020Z2.0A-MEGA-64	2	F	■	5,0	6	10	50	0,2	2,0	2	■
02623435	760050R040Z2.0A-MEGA-64	2	F	■	5,0	6	10	50	0,4	2,0	2	■
02734053	760060R020Z4.0A-MEGA-64	2	D	■	6,0	6	12	50	0,2	-	4	■
02623433	760060R040Z4.0A-MEGA-64	2	D	■	6,0	6	12	50	0,4	-	4	■
02623436	760080R040Z4.0A-MEGA-64	2	D	■	8,0	8	16	55	0,4	-	4	■
02623437	760080R100Z4.0A-MEGA-64	2	D	■	8,0	8	16	55	1,0	-	4	■
02623460	760100R040Z4.0A-MEGA-64	2	D	■	10,0	10	20	65	0,4	-	4	■
02623463	760100R100Z4.0A-MEGA-64	2	D	■	10,0	10	20	65	1,0	-	4	■
02623466	760100R150Z4.0A-MEGA-64	2	D	■	10,0	10	20	65	1,5	-	4	■
02623819	760120R040Z4.0A-MEGA-64	2	D	■	12,0	12	24	75	0,4	-	4	■
02623825	760120R100Z4.0A-MEGA-64	2	D	■	12,0	12	24	75	1,0	-	4	■
02623828	760120R150Z4.0A-MEGA-64	2	D	■	12,0	12	24	75	1,5	-	4	■
02623833	760120R310Z4.0A-MEGA-64	2	D	■	12,0	12	24	75	3,1	-	4	■
02734055	760200R040Z4.0A-MEGA-64	2	D	■	20,0	20	45	100	0,4	-	4	■
02623852	760200R080Z4.0A-MEGA-64	2	D	■	20,0	20	45	100	0,8	-	4	■
02623438	760L080R040Z4.0A-MEGA-64	3	D	■	8,0	8	28	65	0,4	-	4	■
02623461	760L100R040Z4.0A-MEGA-64	3	D	■	10,0	10	36	75	0,4	-	4	■
02623464	760L100R100Z4.0A-MEGA-64	3	D	■	10,0	10	36	75	1,0	-	4	■
02623467	760L100R150Z4.0A-MEGA-64	3	D	■	10,0	10	36	75	1,5	-	4	■
02623472	760L100R200Z4.0A-MEGA-64	3	D	■	10,0	10	36	75	2,0	-	4	■
02623807	760L100R310Z4.0A-MEGA-64	3	D	■	10,0	10	36	75	3,1	-	4	■
02623821	760L120R040Z4.0A-MEGA-64	3	D	■	12,0	12	42	90	0,4	-	4	■
02623826	760L120R100Z4.0A-MEGA-64	3	D	■	12,0	12	42	90	1,0	-	4	■
02623829	760L120R150Z4.0A-MEGA-64	3	D	■	12,0	12	42	90	1,5	-	4	■
02623831	760L120R200Z4.0A-MEGA-64	3	D	■	12,0	12	42	90	2,0	-	4	■
02623838	760L120R400Z4.0A-MEGA-64	3	D	■	12,0	12	42	90	4,0	-	4	■
02623840	760L160R040Z4.0A-MEGA-64	3	D	■	16,0	16	50	100	0,4	-	4	■
02623842	760L160R100Z4.0A-MEGA-64	3	D	■	16,0	16	50	100	1,0	-	4	■
02623844	760L160R150Z4.0A-MEGA-64	3	D	■	16,0	16	50	100	1,5	-	4	■
02623846	760L160R200Z4.0A-MEGA-64	3	D	■	16,0	16	50	100	2,0	-	4	■

ICC = Internal Coolant Channel

■ Stock standard. Subject to change refer to current price- and stock-list

JHP760 – High performance – Superalloy – Square – 2-4 Flutes – Weldon – Corner radius – ICC



Tolerances:
 DMM=h5
 DC=-0,02/-0,4 mm
 RE= ±0,03 mm
 Regrind possible if DC is ≥Ø6

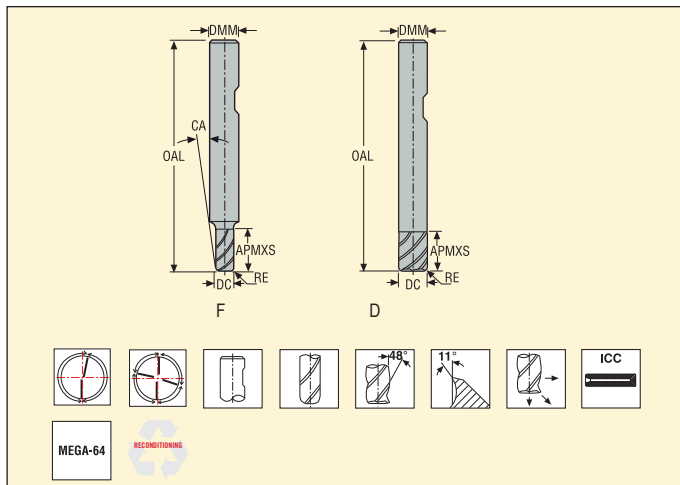

Ordering and Product No.	Designation	Length index	Tool shape	ICC	Dimensions in mm					CA	PCEDC	Weldon
					DC	DMM	APMXS	OAL	RE			
02734065	760040R020Z2.0A-MEGA-64W	2	F	■	4,0	6	8	50	0,2	-	2	□
02669339	760040R040Z2.0A-MEGA-64W	2	F	■	4,0	6	8	50	0,4	-	2	□
02734068	760050R020Z2.0A-MEGA-64W	2	F	■	5,0	6	10	50	0,2	-	2	□
02669340	760050R040Z2.0A-MEGA-64W	2	F	■	5,0	6	10	50	0,4	-	2	□
02734069	760060R020Z4.0A-MEGA-64W	2	D	■	6,0	6	12	50	0,2	-	4	□
02669341	760060R040Z4.0A-MEGA-64W	2	D	■	6,0	6	12	50	0,4	-	4	□
02669343	760080R040Z4.0A-MEGA-64W	2	D	■	8,0	8	16	55	0,4	-	4	□
02669344	760080R100Z4.0A-MEGA-64W	2	D	■	8,0	8	16	55	1,0	-	4	□
02623442	760100R040Z4A-MEGA-64	2	D	■	10,0	10	20	65	0,4	-	4	■
02623462	760100R100Z4A-MEGA-64	2	D	■	10,0	10	20	65	1,0	-	4	■
02623465	760100R150Z4A-MEGA-64	2	D	■	10,0	10	20	65	1,5	-	4	■
02623468	760100R200Z4A-MEGA-64	2	D	■	10,0	10	20	65	2,0	-	4	■
02623817	760120R040Z4A-MEGA-64	2	D	■	12,0	12	24	75	0,4	-	4	■
02623824	760120R100Z4A-MEGA-64	2	D	■	12,0	12	24	75	1,0	-	4	■
02623827	760120R150Z4A-MEGA-64	2	D	■	12,0	12	24	75	1,5	-	4	■
02623830	760120R200Z4A-MEGA-64	2	D	■	12,0	12	24	75	2,0	-	4	■
02623835	760120R400Z4A-MEGA-64	2	D	■	12,0	12	24	75	4,0	-	4	■
02623839	760160R040Z4A-MEGA-64	2	D	■	16,0	16	40	90	0,4	-	4	■
02623841	760160R100Z4A-MEGA-64	2	D	■	16,0	16	40	90	1,0	-	4	■
02623843	760160R150Z4A-MEGA-64	2	D	■	16,0	16	40	90	1,5	-	4	■
02623845	760160R200Z4A-MEGA-64	2	D	■	16,0	16	40	90	2,0	-	4	■
02734054	760200R040Z4A-MEGA-64	2	D	■	20,0	20	45	100	0,4	-	4	■
02623851	760200R080Z4A-MEGA-64	2	D	■	20,0	20	45	100	0,8	-	4	■
02734057	760250R050Z4A-MEGA-64	2	D	■	25,0	25	45	110	0,5	-	4	■
02720459	760L080R040Z4.0A-MEGA-64W	3	D	■	8,0	8	28	65	0,4	-	4	□
02669345	760L100R040Z4.0A-MEGA-64W	3	D	■	10,0	10	36	75	0,4	-	4	□
02669346	760L100R100Z4.0A-MEGA-64W	3	D	■	10,0	10	36	75	1,0	-	4	□
02669347	760L100R150Z4.0A-MEGA-64W	3	D	■	10,0	10	36	75	1,5	-	4	□
02669348	760L100R200Z4.0A-MEGA-64W	3	D	■	10,0	10	36	75	2,0	-	4	□
02669350	760L120R040Z4.0A-MEGA-64W	3	D	■	12,0	12	42	90	0,4	-	4	□
02669351	760L120R100Z4.0A-MEGA-64W	3	D	■	12,0	12	42	90	1,0	-	4	□
02669352	760L120R150Z4.0A-MEGA-64W	3	D	■	12,0	12	42	90	1,5	-	4	□
02669353	760L120R200Z4.0A-MEGA-64W	3	D	■	12,0	12	42	90	2,0	-	4	□
02669356	760L160R040Z4.0A-MEGA-64W	3	D	■	16,0	16	50	100	0,4	-	4	□
02669357	760L160R100Z4.0A-MEGA-64W	3	D	■	16,0	16	50	100	1,0	-	4	□
02669358	760L160R150Z4.0A-MEGA-64W	3	D	■	16,0	16	50	100	1,5	-	4	□
02669359	760L160R200Z4.0A-MEGA-64W	3	D	■	16,0	16	50	100	2,0	-	4	□

ICC = Internal Coolant Channel

■ Stock standard. Subject to change refer to current price- and stock-list □ Weldon available, delivery time is 3 days.

Cutting data – JHP760 Slot milling

SMG		a _p /DC	f _z										v _c
			4	5	6	8	10	12	16	20	25		
M1	E	1,0	0,016	0,020	0,024	0,032	0,040	0,050	0,065	0,080	0,10	110 (90 – 130)	
M2	E	1,0	0,016	0,020	0,024	0,032	0,040	0,050	0,065	0,080	0,10	90 (75 – 105)	
M3	E	0,80	0,013	0,016	0,019	0,026	0,032	0,038	0,050	0,065	0,080	60 (48 – 70)	
M4	E	0,60	0,013	0,016	0,019	0,026	0,032	0,038	0,050	0,065	0,080	45 (37 – 55)	
M5	E	0,60	0,013	0,016	0,019	0,026	0,032	0,038	0,050	0,065	0,080	37 (31 – 44)	

Cutting data – JHP760 Side milling

SMG		a _e /DC	a _p /DC	f _z										v _c
				4	5	6	8	10	12	16	20	25		
M1	E	0,30	1,5	0,032	0,040	0,048	0,065	0,080	0,095	0,12	0,13	0,15	120 (100 – 145)	
M2	E	0,30	1,5	0,028	0,036	0,044	0,060	0,070	0,085	0,11	0,12	0,14	100 (85 – 120)	
M3	E	0,30	1,4	0,026	0,032	0,038	0,050	0,065	0,075	0,095	0,11	0,12	65 (50 – 75)	
M4	E	0,30	1,1	0,022	0,028	0,034	0,046	0,055	0,065	0,085	0,095	0,11	49 (41 – 60)	
M5	E	0,30	1,1	0,022	0,028	0,034	0,046	0,055	0,065	0,085	0,095	0,11	41 (34 – 48)	

For cutting data recalculations, see page 411-418.

SMG = Seco material group

Coolant = A=air D=dry E=emulsion M=mist spray

v_c = m/min

f_z = mm

a_p (mm)/DC (mm)= factor

a_e (mm)/DC (mm)= factor

All cutting data are target values

JHP770 – High performance – Titanium – Square – 4-5 Flutes – Cylindrical – Corner radius – internal coolant channel



Tolerances:
 DMM= h5
 DC= e7
 RE= ±0,02 mm
 Regrind possible if DC is ≥Ø6

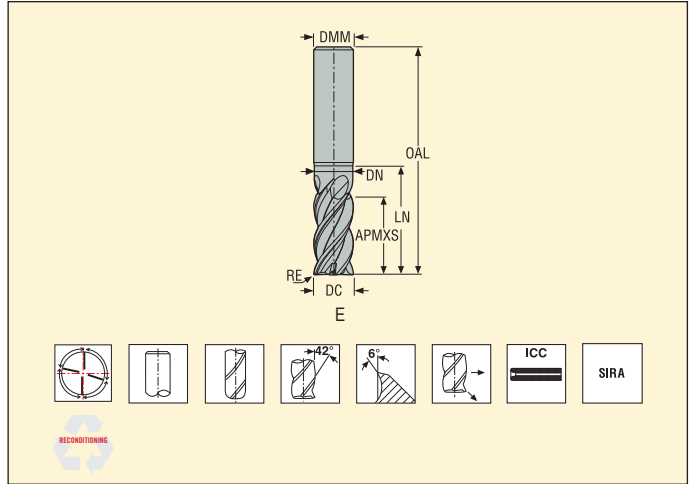

Ordering and Product No.	Designation	Length index	Tool shape	ICC	Dimensions in mm						RE	PCE/DC	Cylindrical
					DC	DMM	APMXS	OAL	LN	DN			
02760645	JHP770060E2R030.0Z4A-SIRA	2	E	■	6,0	6	12	60	18	5,6	0,3	4	■
02760653	JHP770080E2R040.0Z4A-SIRA	2	E	■	8,0	8	16	65	24	7,4	0,4	4	■
02823416	JHP770080E2R050.0Z4A-SIRA	2	E	■	8,0	8	16	65	24	7,4	0,5	4	■
02760654	JHP770100E2R040.0Z4A-SIRA	2	E	■	10,0	10	20	75	30	9,4	0,4	4	■
02823417	JHP770100E2R050.0Z4A-SIRA	2	E	■	10,0	10	20	75	30	9,4	0,5	4	■
02760655	JHP770100E2R080.0Z4A-SIRA	2	E	■	10,0	10	20	75	30	9,4	0,8	4	■
02823418	JHP770100E2R100.0Z4A-SIRA	2	E	■	10,0	10	20	75	30	9,4	1,0	4	■
02760656	JHP770120E2R040.0Z4A-SIRA	2	E	■	12,0	12	24	90	36	11,4	0,4	4	■
02823419	JHP770120E2R050.0Z4A-SIRA	2	E	■	12,0	12	24	90	36	11,4	0,5	4	■
02760657	JHP770120E2R080.0Z4A-SIRA	2	E	■	12,0	12	24	90	36	11,4	0,8	4	■
02823420	JHP770120E2R100.0Z4A-SIRA	2	E	■	12,0	12	24	90	36	11,4	1,0	4	■
02760659	JHP770120E2R250.0Z4A-SIRA	2	E	■	12,0	12	24	90	36	11,4	2,5	4	■
02823421	JHP770140E2R050.0Z4A-SIRA	2	E	■	14,0	14	28	95	42	13,4	0,5	4	■
02760661	JHP770160E2R040.0Z4A-SIRA	2	E	■	16,0	16	32	100	45	15,4	0,4	4	■
02823422	JHP770160E2R050.0Z4A-SIRA	2	E	■	16,0	16	32	100	45	15,4	0,5	4	■
02760662	JHP770160E2R080.0Z4A-SIRA	2	E	■	16,0	16	32	100	45	15,4	0,8	4	■
02823423	JHP770160E2R100.0Z4A-SIRA	2	E	■	16,0	16	32	100	45	15,4	1,0	4	■
02760663	JHP770160E2R250.0Z4A-SIRA	2	E	■	16,0	16	32	100	45	15,4	2,5	4	■
02760664	JHP770160E2R310.0Z4A-SIRA	2	E	■	16,0	16	32	100	45	15,4	3,1	4	■
02760665	JHP770160E2R400.0Z4A-SIRA	2	E	■	16,0	16	32	100	45	15,4	4,0	4	■
02823424	JHP770200E2R050.0Z4A-SIRA	2	E	■	20,0	20	40	115	55	19,4	0,5	4	■
02823425	JHP770200E2R100.0Z4A-SIRA	2	E	■	20,0	20	40	115	55	19,4	1,0	4	■
02760668	JHP770200E2R250.0Z4A-SIRA	2	E	■	20,0	20	40	115	55	19,4	2,5	4	■
02760669	JHP770200E2R310.0Z4A-SIRA	2	E	■	20,0	20	40	115	55	19,4	3,1	4	■
02760670	JHP770200E2R400.0Z4A-SIRA	2	E	■	20,0	20	40	115	55	19,4	4,0	4	■
02823427	JHP770250E2R100.0Z4A-SIRA	2	E	■	25,0	25	50	130	65	24,4	1,0	4	■
02760673	JHP770250E2R310.0Z4A-SIRA	2	E	■	25,0	25	50	130	65	24,4	3,1	4	■
02760674	JHP770250E2R400.0Z4A-SIRA	2	E	■	25,0	25	50	130	65	24,4	4,0	4	■

Remark: if corner radius is >15% of DC → $a_p = -30\%$, $f_z = -20\%$

ICC = Internal Coolant Channel

■ Stock standard. Subject to change refer to current price- and stock-list

JHP770 - High performance - Titanium - Square - 4-5 Flutes - Cylindrical - Corner radius - internal coolant channel



Tolerances:
 DMM= h5
 DC= e7
 RE= ±0,02 mm
 Regrind possible if DC is ≥ø6

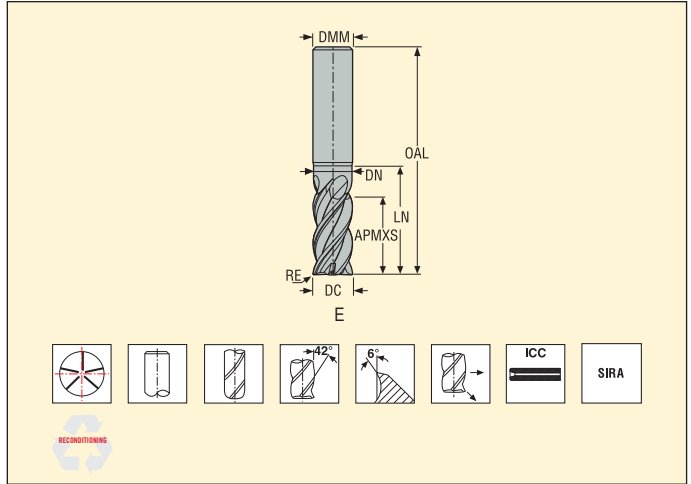

Ordering and Product No.	Designation	Length index	Tool shape	ICC	Dimensions in mm						RE	PCEDC	Cylindrical
					DC	DMM	APMXS	OAL	LN	DN			
02810129	JHP770160E2R050.0Z5A-SIRA	2	E	■	16,0	16	32	100	45	15,4	0,5	5	■
02810130	JHP770160E2R100.0Z5A-SIRA	2	E	■	16,0	16	32	100	45	15,4	1,0	5	■
02810131	JHP770160E2R250.0Z5A-SIRA	2	E	■	16,0	16	32	100	45	15,4	2,5	5	■
02810132	JHP770160E2R310.0Z5A-SIRA	2	E	■	16,0	16	32	100	45	15,4	3,1	5	■
02810133	JHP770160E2R400.0Z5A-SIRA	2	E	■	16,0	16	32	100	45	15,4	4,0	5	■
03093701	JHP770160E2R600.0Z5A-SIRA	2	E	■	16,0	16	32	100	45	15,4	6,0	5	■
02810134	JHP770200E2R050.0Z5A-SIRA	2	E	■	20,0	20	40	115	55	19,4	0,5	5	■
02810135	JHP770200E2R100.0Z5A-SIRA	2	E	■	20,0	20	40	115	55	19,4	1,0	5	■
02810136	JHP770200E2R250.0Z5A-SIRA	2	E	■	20,0	20	40	115	55	19,4	2,5	5	■
02810137	JHP770200E2R310.0Z5A-SIRA	2	E	■	20,0	20	40	115	55	19,4	3,1	5	■
02810138	JHP770200E2R400.0Z5A-SIRA	2	E	■	20,0	20	40	115	55	19,4	4,0	5	■
03093702	JHP770200E2R600.0Z5A-SIRA	2	E	■	20,0	20	40	115	55	19,4	6,0	5	■
02810139	JHP770250E2R050.0Z5A-SIRA	2	E	■	25,0	25	50	130	65	24,4	0,5	5	■
02810141	JHP770250E2R310.0Z5A-SIRA	2	E	■	25,0	25	50	130	65	24,4	3,1	5	■
02810142	JHP770250E2R400.0Z5A-SIRA	2	E	■	25,0	25	50	130	65	24,4	4,0	5	■
03093703	JHP770250E2R600.0Z5A-SIRA	2	E	■	25,0	25	50	130	65	24,4	6,0	5	■

Remark: if comerradius is >15% of DC → a_p=-30%, f_z=-20%
 ICC = Internal Coolant Channel
 ■ Stock standard. Subject to change refer to current price- and stock-list

JHP770 – High performance – Titanium – Square – 4-5 Flutes – Weldon – Corner radius – internal coolant channel



Tolerances:
 DMM= h5
 DC= e7
 RE= ±0,02 mm
 Regrind possible if DC is ≥Ø6

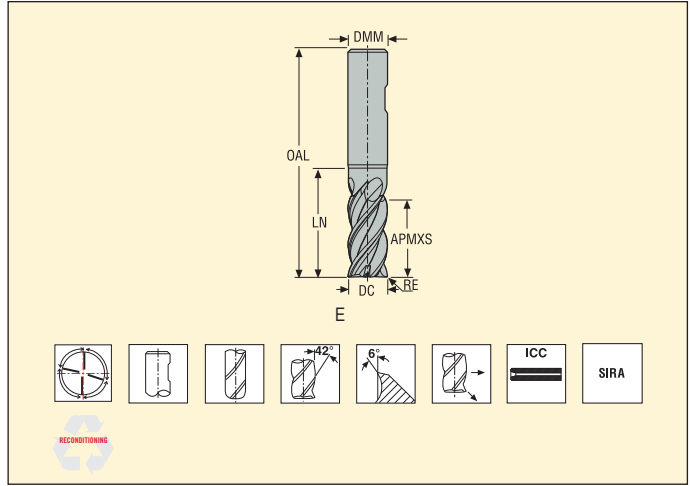

Ordering and Product No.	Designation	Length index	Tool shape	ICC	Dimensions in mm						RE	PCEDC	Weldon
					DC	DMM	APMXS	OAL	LN	DN			
02760796	JHP770060E2R030.3Z4A-SIRA	2	E	■	6,0	6	12	60	18	5,6	0,3	4	■
02760799	JHP770080E2R040.3Z4A-SIRA	2	E	■	8,0	8	16	65	24	7,4	0,4	4	□
02823428	JHP770080E2R050.3Z4A-SIRA	2	E	■	8,0	8	16	65	24	7,4	0,5	4	■
02760801	JHP770100E2R040.3Z4A-SIRA	2	E	■	10,0	10	20	75	30	9,4	0,4	4	□
02823429	JHP770100E2R050.3Z4A-SIRA	2	E	■	10,0	10	20	75	30	9,4	0,5	4	■
02760802	JHP770100E2R080.3Z4A-SIRA	2	E	■	10,0	10	20	75	30	9,4	0,8	4	□
02823430	JHP770100E2R100.3Z4A-SIRA	2	E	■	10,0	10	20	75	30	9,4	1,0	4	■
02760803	JHP770120E2R040.3Z4A-SIRA	2	E	■	12,0	12	24	90	36	11,4	0,4	4	□
02823431	JHP770120E2R050.3Z4A-SIRA	2	E	■	12,0	12	24	90	36	11,4	0,5	4	■
02760804	JHP770120E2R080.3Z4A-SIRA	2	E	■	12,0	12	24	90	36	11,4	0,8	4	□
02823432	JHP770120E2R100.3Z4A-SIRA	2	E	■	12,0	12	24	90	36	11,4	1,0	4	■
02760805	JHP770120E2R250.3Z4A-SIRA	2	E	■	12,0	12	24	90	36	11,4	2,5	4	□
02823433	JHP770140E2R050.3Z4A-SIRA	2	E	■	14,0	14	28	95	42	13,4	0,5	4	■
02760807	JHP770160E2R040.3Z4A-SIRA	2	E	■	16,0	16	32	100	45	15,4	0,4	4	□
02823434	JHP770160E2R050.3Z4A-SIRA	2	E	■	16,0	16	32	100	45	15,4	0,5	4	■
02760809	JHP770160E2R080.3Z4A-SIRA	2	E	■	16,0	16	32	100	45	15,4	0,8	4	□
02823435	JHP770160E2R100.3Z4A-SIRA	2	E	■	16,0	16	32	100	45	15,4	1,0	4	■
02760810	JHP770160E2R250.3Z4A-SIRA	2	E	■	16,0	16	32	100	45	15,4	2,5	4	■
02760811	JHP770160E2R310.3Z4A-SIRA	2	E	■	16,0	16	32	100	45	15,4	3,1	4	□
02760817	JHP770160E2R400.3Z4A-SIRA	2	E	■	16,0	16	32	100	45	15,4	4,0	4	□
02823436	JHP770200E2R050.3Z4A-SIRA	2	E	■	20,0	20	40	115	55	19,4	0,5	4	■
02823437	JHP770200E2R100.3Z4A-SIRA	2	E	■	20,0	20	40	115	55	19,4	1,0	4	■
02760823	JHP770200E2R250.3Z4A-SIRA	2	E	■	20,0	20	40	115	55	19,4	2,5	4	□
02760824	JHP770200E2R310.3Z4A-SIRA	2	E	■	20,0	20	40	115	55	19,4	3,1	4	□
02760825	JHP770200E2R400.3Z4A-SIRA	2	E	■	20,0	20	40	115	55	19,4	4,0	4	□
02760828	JHP770250E2R310.3Z4A-SIRA	2	E	■	25,0	25	50	130	65	24,4	3,1	4	□
02760829	JHP770250E2R400.3Z4A-SIRA	2	E	■	25,0	25	50	130	65	24,4	4,0	4	□

Remark: if corner radius is >15% of DC → a_p=-30%, f_z=-20%

ICC = Internal Coolant Channel

■ Stock standard. Subject to change refer to current price- and stock-list □ Weldon available, delivery time is 3 days.

JHP770 – High performance – Titanium – Square – 4-5 Flutes – Weldon – Corner radius – internal coolant channel



Tolerances:
 DMM= h5
 DC= e7
 RE= ±0,02 mm
 Regrind possible if DC is ≥Ø6

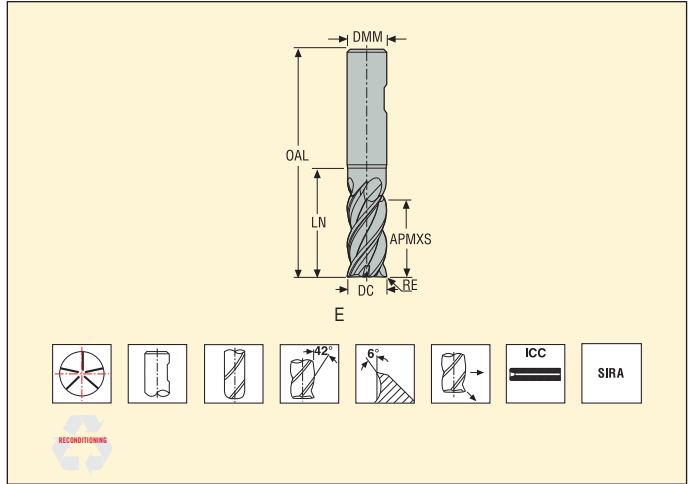

Ordering and Product No.	Designation	Length index	Tool shape	ICC	Dimensions in mm						RE	PCEDC	Weldon
					DC	DMM	APMXS	OAL	LN	DN			
02810143	JHP770160E2R050.3Z5A-SIRA	2	E	■	16,0	16	32	100	45	15,4	0,5	5	■
02810144	JHP770160E2R100.3Z5A-SIRA	2	E	■	16,0	16	32	100	45	15,4	1,0	5	■
02810145	JHP770160E2R250.3Z5A-SIRA	2	E	■	16,0	16	32	100	45	15,4	2,5	5	□
02810146	JHP770160E2R310.3Z5A-SIRA	2	E	■	16,0	16	32	100	45	15,4	3,1	5	■
02810147	JHP770160E2R400.3Z5A-SIRA	2	E	■	16,0	16	32	100	45	15,4	4,0	5	□
03093711	JHP770160E2R600.3Z5A-SIRA	2	E	■	16,0	16	32	100	45	15,4	6,0	5	□
02810148	JHP770200E2R050.3Z5A-SIRA	2	E	■	20,0	20	40	115	55	19,4	0,5	5	■
02810149	JHP770200E2R100.3Z5A-SIRA	2	E	■	20,0	20	40	115	55	19,4	1,0	5	■
02810150	JHP770200E2R250.3Z5A-SIRA	2	E	■	20,0	20	40	115	55	19,4	2,5	5	□
02810151	JHP770200E2R310.3Z5A-SIRA	2	E	■	20,0	20	40	115	55	19,4	3,1	5	■
02810152	JHP770200E2R400.3Z5A-SIRA	2	E	■	20,0	20	40	115	55	19,4	4,0	5	■
03093713	JHP770200E2R600.3Z5A-SIRA	2	E	■	20,0	20	40	115	55	19,4	6,0	5	□
02810153	JHP770250E2R050.3Z5A-SIRA	2	E	■	25,0	25	50	130	65	24,4	0,5	5	■
02810154	JHP770250E2R100.3Z5A-SIRA	2	E	■	25,0	25	50	130	65	24,4	1,0	5	■
02810155	JHP770250E2R310.3Z5A-SIRA	2	E	■	25,0	25	50	130	65	24,4	3,1	5	□
02810156	JHP770250E2R400.3Z5A-SIRA	2	E	■	25,0	25	50	130	65	24,4	4,0	5	□
03093715	JHP770250E2R600.3Z5A-SIRA	2	E	■	25,0	25	50	130	65	24,4	6,0	5	□

Remark: if comerradius is >15% of DC → a_p=-30%, f_z=-20%
 ICC = Internal Coolant Channel
■ Stock standard. **Subject to change refer to current price- and stock-list** □ Weldon available, delivery time is 3 days.



JHP770 – High performance – Titanium – Square – 4-5 Flutes – Safelock – Corner radius – internal coolant channel



Tolerances:
 DMM= h5
 DC= e7
 RE= ±0,02 mm
 Regrind possible if DC is ≥06

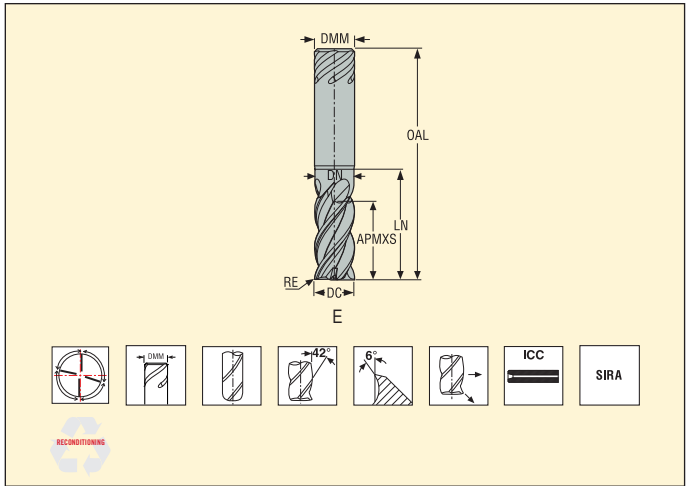

Ordering and Product No.	Designation	Length index	Tool shape	ICC	Dimensions in mm						PCEDC	Safelock	
					DC	DMM	APMXS	OAL	LN	DN			RE
02927936	JHP770060E2R030.9Z4A-SIRA	2	E	■	6,0	6	12	60	18	6	0,3	4	<input type="checkbox"/>
02927937	JHP770080E2R040.9Z4A-SIRA	2	E	■	8,0	8	16	65	24	7	0,4	4	<input type="checkbox"/>
02927938	JHP770080E2R050.9Z4A-SIRA	2	E	■	8,0	8	16	65	24	7	0,5	4	<input type="checkbox"/>
02927939	JHP770100E2R040.9Z4A-SIRA	2	E	■	10,0	10	20	75	30	9	0,4	4	<input type="checkbox"/>
02927940	JHP770100E2R050.9Z4A-SIRA	2	E	■	10,0	10	20	75	30	9	0,5	4	<input type="checkbox"/>
02927941	JHP770100E2R080.9Z4A-SIRA	2	E	■	10,0	10	20	75	30	9	0,8	4	<input type="checkbox"/>
02927942	JHP770100E2R100.9Z4A-SIRA	2	E	■	10,0	10	20	75	30	9	1,0	4	<input type="checkbox"/>
02927943	JHP770120E2R040.9Z4A-SIRA	2	E	■	12,0	12	24	90	36	11	0,4	4	<input type="checkbox"/>
02927944	JHP770120E2R050.9Z4A-SIRA	2	E	■	12,0	12	24	90	36	11	0,5	4	<input type="checkbox"/>
02927945	JHP770120E2R080.9Z4A-SIRA	2	E	■	12,0	12	24	90	36	11	0,8	4	<input type="checkbox"/>
02927946	JHP770120E2R100.9Z4A-SIRA	2	E	■	12,0	12	24	90	36	11	1,0	4	<input type="checkbox"/>
02927947	JHP770120E2R250.9Z4A-SIRA	2	E	■	12,0	12	24	90	36	11	2,5	4	<input type="checkbox"/>
02927950	JHP770140E2R050.9Z4A-SIRA	2	E	■	14,0	14	28	95	42	13	0,5	4	<input type="checkbox"/>
02927948	JHP770160E2R040.9Z4A-SIRA	2	E	■	16,0	16	32	100	45	15	0,4	4	<input type="checkbox"/>
02927951	JHP770160E2R080.9Z4A-SIRA	2	E	■	16,0	16	32	100	45	15	0,8	4	<input type="checkbox"/>
02927952	JHP770160E2R100.9Z4A-SIRA	2	E	■	16,0	16	32	100	45	15	1,0	4	<input type="checkbox"/>
02927954	JHP770160E2R250.9Z4A-SIRA	2	E	■	16,0	16	32	100	45	15	2,5	4	<input type="checkbox"/>
02927956	JHP770160E2R310.9Z4A-SIRA	2	E	■	16,0	16	32	100	45	15	3,1	4	<input type="checkbox"/>
02927957	JHP770160E2R400.9Z4A-SIRA	2	E	■	16,0	16	32	100	45	15	4,0	4	<input type="checkbox"/>
02927960	JHP770200E2R050.9Z4A-SIRA	2	E	■	20,0	20	40	115	55	19	0,5	4	<input type="checkbox"/>
02927962	JHP770200E2R100.9Z4A-SIRA	2	E	■	20,0	20	40	115	55	19	1,0	4	<input type="checkbox"/>
02927964	JHP770200E2R250.9Z4A-SIRA	2	E	■	20,0	20	40	115	55	19	2,5	4	<input type="checkbox"/>
02927966	JHP770200E2R310.9Z4A-SIRA	2	E	■	20,0	20	40	115	55	19	3,1	4	<input type="checkbox"/>
02927968	JHP770200E2R400.9Z4A-SIRA	2	E	■	20,0	20	40	115	55	19	4,0	4	<input type="checkbox"/>
02927972	JHP770250E2R100.9Z4A-SIRA	2	E	■	25,0	25	50	130	65	24	1,0	4	<input type="checkbox"/>
02927975	JHP770250E2R310.9Z4A-SIRA	2	E	■	25,0	25	50	130	65	24	3,1	4	<input type="checkbox"/>
02927976	JHP770250E2R400.9Z4A-SIRA	2	E	■	25,0	25	50	130	65	24	4,0	4	<input type="checkbox"/>
02927978	JHP770160E2R050.9Z4A-SIRA	2	E	■	16,0	16	32	100	45	15	0,5	4	<input type="checkbox"/>

Remark: if comerradius is >15% of DC → $a_p = -30\%$, $f_z = -20\%$

ICC = Internal Coolant Channel

Safelock available. Subject to change, refer to current Price and Stock List.

JHP770 - High performance - Titanium - Square - 4-5 Flutes - Safelock - Corner radius - internal coolant channel



Tolerances:
 DMM= h5
 DC= e7
 RE= ±0,02 mm
 Regrind possible if DC is ≥ø6

Ordering and Product No.	Designation	Length index	Tool shape	ICC	Dimensions in mm						RE	PCEDC	Safelock
					DC	DMM	APMXS	OAL	LN	DN			
02927949	JHP770160E2R050.9Z5A-SIRA	2	E	■	16,0	16	32	100	45	15	0,5	5	<input type="checkbox"/>
02927953	JHP770160E2R100.9Z5A-SIRA	2	E	■	16,0	16	32	100	45	15	1,0	5	<input type="checkbox"/>
02927955	JHP770160E2R250.9Z5A-SIRA	2	E	■	16,0	16	32	100	45	15	2,5	5	<input type="checkbox"/>
02927957	JHP770160E2R310.9Z5A-SIRA	2	E	■	16,0	16	32	100	45	15	3,1	5	<input type="checkbox"/>
02927959	JHP770160E2R400.9Z5A-SIRA	2	E	■	16,0	16	32	100	45	15	4,0	5	<input type="checkbox"/>
03093712	JHP770160E2R600.9Z5A-SIRA	2	E	■	16,0	16	32	100	45	15	6,0	5	<input type="checkbox"/>
02927961	JHP770200E2R050.9Z5A-SIRA	2	E	■	20,0	20	40	115	55	19	0,5	5	<input type="checkbox"/>
02927963	JHP770200E2R100.9Z5A-SIRA	2	E	■	20,0	20	40	115	55	19	1,0	5	<input type="checkbox"/>
02927965	JHP770200E2R250.9Z5A-SIRA	2	E	■	20,0	20	40	115	55	19	2,5	5	<input type="checkbox"/>
02927967	JHP770200E2R310.9Z5A-SIRA	2	E	■	20,0	20	40	115	55	19	3,1	5	<input type="checkbox"/>
02927969	JHP770200E2R400.9Z5A-SIRA	2	E	■	20,0	20	40	115	55	19	4,0	5	<input type="checkbox"/>
03093714	JHP770200E2R600.9Z5A-SIRA	2	E	■	20,0	20	40	115	55	19	6,0	5	<input type="checkbox"/>
02927971	JHP770250E2R050.9Z5A-SIRA	2	E	■	25,0	25	50	130	65	24	0,5	5	<input type="checkbox"/>
02927974	JHP770250E2R310.9Z5A-SIRA	2	E	■	25,0	25	50	130	65	24	3,1	5	<input type="checkbox"/>
02927977	JHP770250E2R400.9Z5A-SIRA	2	E	■	25,0	25	50	130	65	24	4,0	5	<input type="checkbox"/>
03093716	JHP770250E2R600.9Z5A-SIRA	2	E	■	25,0	25	50	130	65	24	6,0	5	<input type="checkbox"/>

Remark: if corner radius is >15% of DC → a_p=-30%, f_z=-20%
 ICC = Internal Coolant Channel
 Safelock available. Subject to change, refer to current Price and Stock List.

Cutting data – JHP770 Slot milling

SMG		a_p/DC	f_z								v_c
			6	8	10	12	14	16	20	25	
S11	E	1,6	0,030	0,040	0,050	0,060	0,070	0,080	0,10	0,11	90 (90 – 120)
S12	E	1,6	0,030	0,040	0,050	0,060	0,070	0,080	0,10	0,11	70 (70 – 90)
S13	E	1,4	0,030	0,040	0,050	0,060	0,070	0,080	0,10	0,11	55 (55 – 70)

Cutting data – JHP770 Slot milling Internal coolant *

SMG		a_p/DC	f_z								v_c
			6	8	10	12	14	16	20	25	
S11	E	1,6	0,030	0,040	0,050	0,060	0,070	0,080	0,10	0,13	105 (95 – 120)
S12	E	1,6	0,030	0,040	0,050	0,060	0,070	0,080	0,10	0,13	80 (70 – 90)
S13	E	1,4	0,030	0,040	0,050	0,060	0,070	0,080	0,10	0,13	65 (55 – 70)

Cutting data – JHP770 Side milling

SMG		a_g/DC	a_p/DC	f_z								v_c
				6	8	10	12	14	16	20	25	
S11	E	0,40	1,8	0,050	0,065	0,080	0,095	0,11	0,12	0,14	0,14	100 (105 – 135)
S12	E	0,40	1,8	0,050	0,065	0,080	0,095	0,11	0,12	0,14	0,14	80 (80 – 100)
S13	E	0,40	1,8	0,042	0,055	0,070	0,085	0,095	0,11	0,12	0,12	65 (65 – 80)

For cutting data recalculations, see page 411-418.

SMG = Seco material group

Coolant = A=air D=dry E=emulsion M=mist spray

v_c = m/min

f_z = mm

a_p (mm)/DC (mm)= factor

a_g (mm)/DC (mm)= factor

All cutting data are target values

JHP780 – High performance – Superalloy – Square – 4-Flutes – Cylindrical – Corner radius – ICC



Tolerances:

DMM=h5

DC=e7

RE= ±0,02 mm

Regrind possible if DC is ≥Ø6

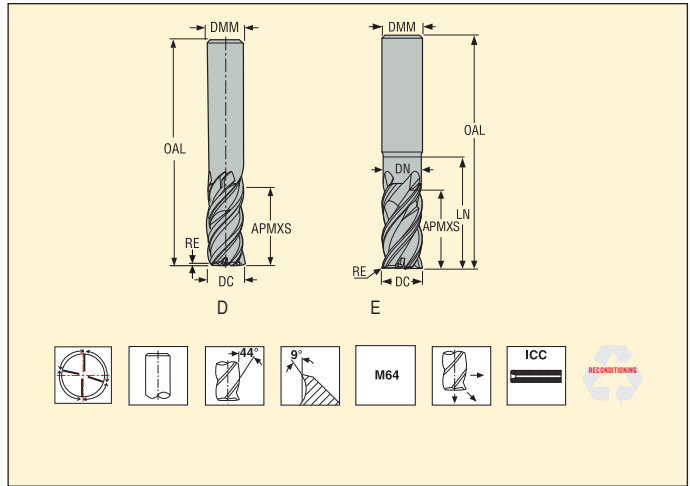

Ordering and Product No.	Designation	Length index	Tool shape	ICC	Dimensions in mm				LN	DN	RE	PCEDC	Cylindrical
					DC	DMM	APMXS	OAL					
03134984	JHP780060D1R030.0Z4A-M64	1	D	■	6,0	6	7,5	47	-	-	0,3	4	■
03134985	JHP780060D1R080.0Z4A-M64	1	D	■	6,0	6	7,5	47	-	-	0,8	4	■
03134986	JHP780080D1R040.0Z4A-M64	1	D	■	8,0	8	10,0	50	-	-	0,4	4	■
03134987	JHP780080D1R080.0Z4A-M64	1	D	■	8,0	8	10,0	50	-	-	0,8	4	■
03134988	JHP780100D1R040.0Z4A-M64	1	D	■	10,0	10	12,5	57	-	-	0,4	4	■
03134989	JHP780100D1R080.0Z4A-M64	1	D	■	10,0	10	12,5	57	-	-	0,8	4	■
03134990	JHP780120D1R040.0Z4A-M64	1	D	■	12,0	12	15,0	65	-	-	0,4	4	■
03134991	JHP780120D1R080.0Z4A-M64	1	D	■	12,0	12	15,0	65	-	-	0,8	4	■
03134992	JHP780060E2R030.0Z4A-M64	2	E	■	6,0	6	12,0	60	18,0	5,6	0,3	4	■
02760834	JHP780060E2R030.0Z4-M64	2	E	■	6,0	6	12,0	60	18,0	5,6	0,3	4	■
03134993	JHP780080E2R040.0Z4A-M64	2	E	■	8,0	8	16,0	65	24,0	7,4	0,4	4	■
02760842	JHP780080E2R040.0Z4-M64	2	E	■	8,0	8	16,0	65	24,0	7,4	0,4	4	■
03134994	JHP780100E2R040.0Z4A-M64	2	E	■	10,0	10	20,0	75	30,0	9,4	0,4	4	■
02760846	JHP780100E2R040.0Z4-M64	2	E	■	10,0	10	20,0	75	30,0	9,4	0,4	4	■
03134995	JHP780100E2R080.0Z4A-M64	2	E	■	10,0	10	20,0	75	30,0	9,4	0,8	4	■
02760847	JHP780100E2R080.0Z4-M64	2	E	■	10,0	10	20,0	75	30,0	9,4	0,8	4	■
03134996	JHP780120E2R040.0Z4A-M64	2	E	■	12,0	12	24,0	90	36,0	11,4	0,4	4	■
02760848	JHP780120E2R040.0Z4-M64	2	E	■	12,0	12	24,0	90	36,0	11,4	0,4	4	■
03134997	JHP780120E2R080.0Z4A-M64	2	E	■	12,0	12	24,0	90	36,0	11,4	0,8	4	■
02760849	JHP780120E2R080.0Z4-M64	2	E	■	12,0	12	24,0	90	36,0	11,4	0,8	4	■
02760850	JHP780120E2R150.0Z4-M64	2	E	■	12,0	12	24,0	90	36,0	11,4	1,5	4	■
02760851	JHP780120E2R250.0Z4-M64	2	E	■	12,0	12	24,0	90	36,0	11,4	2,5	4	■
02760852	JHP780140E2R040.0Z4-M64	2	E	■	14,0	14	28,0	95	42,0	13,4	0,4	4	■
03135000	JHP780160E2R040.0Z4A-M64	2	E	■	16,0	16	32,0	100	45,0	15,4	0,4	4	■
02760853	JHP780160E2R040.0Z4-M64	2	E	■	16,0	16	32,0	100	45,0	15,4	0,4	4	■
03135001	JHP780160E2R080.0Z4A-M64	2	E	■	16,0	16	32,0	100	45,0	15,4	0,8	4	■
02760861	JHP780160E2R080.0Z4-M64	2	E	■	16,0	16	32,0	100	45,0	15,4	0,8	4	■
02760862	JHP780160E2R310.0Z4-M64	2	E	■	16,0	16	32,0	100	45,0	15,4	3,1	4	■
02760863	JHP780160E2R400.0Z4-M64	2	E	■	16,0	16	32,0	100	45,0	15,4	4,0	4	■
03093704	JHP780160E2R600.0Z4-M64	2	E	■	16,0	16	32,0	100	45,0	15,4	6,0	4	■
02760865	JHP780200E2R040.0Z4-M64	2	E	■	20,0	20	40,0	115	55,0	19,4	0,4	4	■
02760866	JHP780200E2R080.0Z4-M64	2	E	■	20,0	20	40,0	115	55,0	19,4	0,8	4	■
02760867	JHP780200E2R310.0Z4-M64	2	E	■	20,0	20	40,0	115	55,0	19,4	3,1	4	■
02760868	JHP780200E2R400.0Z4-M64	2	E	■	20,0	20	40,0	115	55,0	19,4	4,0	4	■
03093706	JHP780200E2R600.0Z4-M64	2	E	■	20,0	20	40,0	115	55,0	19,4	6,0	4	■
02760870	JHP780250E2R080.0Z4-M64	2	E	■	25,0	25	50,0	130	65,0	24,4	0,8	4	■
02760874	JHP780250E2R400.0Z4-M64	2	E	■	25,0	25	50,0	130	65,0	24,4	4,0	4	■
03093707	JHP780250E2R600.0Z4-M64	2	E	■	25,0	25	50,0	130	65,0	24,4	6,0	4	■

ICC = Internal Coolant Channel

■ Stock standard. Subject to change refer to current price- and stock-list

JHP780 - High performance - Superalloy - Square - 4-Flutes - Weldon - Corner radius - ICC



Tolerances:
 DMM=h5
 DC=e7
 RE= ±0,02 mm
 Regrind possible if DC is ≥Ø6

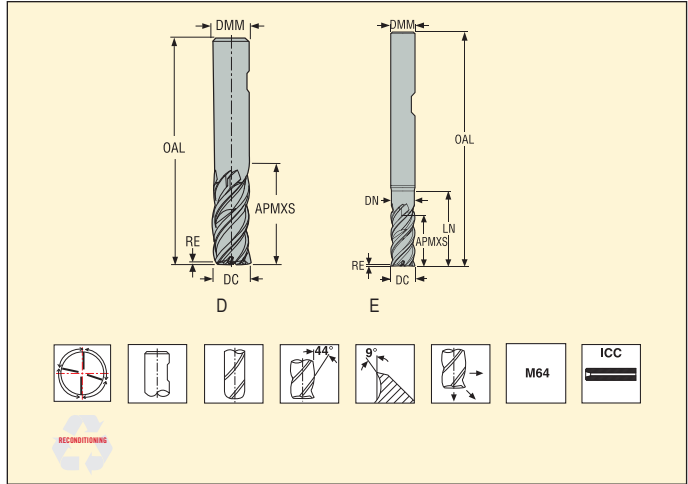

Ordering and Product No.	Designation	Length index	Tool shape	ICC	Dimensions in mm							PCEDC	Weldon
					DC	DMM	APMXS	OAL	LN	DN	RE		
03135445	JHP780060D1R030.3Z4A-M64	1	D	■	6,0	6	7,5	47	-	-	0,3	4	■
03135446	JHP780060D1R080.3Z4A-M64	1	D	■	6,0	6	7,5	47	-	-	0,8	4	■
03135447	JHP780080D1R040.3Z4A-M64	1	D	■	8,0	8	10,0	50	-	-	0,4	4	■
03135449	JHP780080D1R080.3Z4A-M64	1	D	■	8,0	8	10,0	50	-	-	0,8	4	■
03135450	JHP780100D1R040.3Z4A-M64	1	D	■	10,0	10	12,5	57	-	-	0,4	4	■
03135451	JHP780100D1R080.3Z4A-M64	1	D	■	10,0	10	12,5	57	-	-	0,8	4	■
03135452	JHP780120D1R040.3Z4A-M64	1	D	■	12,0	12	15,0	65	-	-	0,4	4	■
03135453	JHP780120D1R080.3Z4A-M64	1	D	■	12,0	12	15,0	65	-	-	0,8	4	■
03135454	JHP780060E2R030.3Z4A-M64	2	E	■	6,0	6	12,0	60	18,0	5,6	0,3	4	■
02760878	JHP780060E2R030.3Z4-M64	2	E	■	6,0	6	12,0	60	18,0	5,6	0,3	4	■
03135455	JHP780080E2R040.3Z4A-M64	2	E	■	8,0	8	16,0	65	24,0	7,4	0,4	4	■
02760879	JHP780080E2R040.3Z4-M64	2	E	■	8,0	8	16,0	65	24,0	7,4	0,4	4	■
03135456	JHP780100E2R040.3Z4A-M64	2	E	■	10,0	10	20,0	75	30,0	9,4	0,4	4	■
02760880	JHP780100E2R040.3Z4-M64	2	E	■	10,0	10	20,0	75	30,0	9,4	0,4	4	■
03135457	JHP780100E2R080.3Z4A-M64	2	E	■	10,0	10	20,0	75	30,0	9,4	0,8	4	■
02760881	JHP780100E2R080.3Z4-M64	2	E	■	10,0	10	20,0	75	30,0	9,4	0,8	4	■
03134998	JHP780120E2R040.3Z4A-M64	2	E	■	12,0	12	24,0	90	36,0	11,4	0,4	4	■
02760883	JHP780120E2R040.3Z4-M64	2	E	■	12,0	12	24,0	90	36,0	11,4	0,4	4	■
03134999	JHP780120E2R080.3Z4A-M64	2	E	■	12,0	12	24,0	90	36,0	11,4	0,8	4	■
02760885	JHP780120E2R080.3Z4-M64	2	E	■	12,0	12	24,0	90	36,0	11,4	0,8	4	■
02760887	JHP780120E2R150.3Z4-M64	2	E	■	12,0	12	24,0	90	36,0	11,4	1,5	4	■
02766989	JHP780120E2R250.3Z4-M64	2	E	■	12,0	12	24,0	90	36,0	11,4	2,5	4	■
02760888	JHP780140E2R040.3Z4-M64	2	E	■	14,0	14	28,0	95	42,0	13,4	0,4	4	■
03135002	JHP780160E2R040.3Z4A-M64	2	E	■	16,0	16	32,0	100	45,0	15,4	0,4	4	■
02760889	JHP780160E2R040.3Z4-M64	2	E	■	16,0	16	32,0	100	45,0	15,4	0,4	4	■
03135003	JHP780160E2R080.3Z4A-M64	2	E	■	16,0	16	32,0	100	45,0	15,4	0,8	4	■
02760890	JHP780160E2R080.3Z4-M64	2	E	■	16,0	16	32,0	100	45,0	15,4	0,8	4	■
02760893	JHP780160E2R400.3Z4-M64	2	E	■	16,0	16	32,0	100	45,0	15,4	4,0	4	■
03093717	JHP780160E2R600.3Z4-M64	2	E	■	16,0	16	32,0	100	45,0	15,4	6,0	4	□

ICC = Internal Coolant Channel

■ Stock standard. Subject to change refer to current price- and stock-list

JHP780 – High performance – Superalloy – Square – 4-Flutes – Weldon – Corner radius



Tolerances:
 DMM=h5
 DC=e7
 RE= ±0,02 mm
 Regrind possible if DC is ≥Ø6

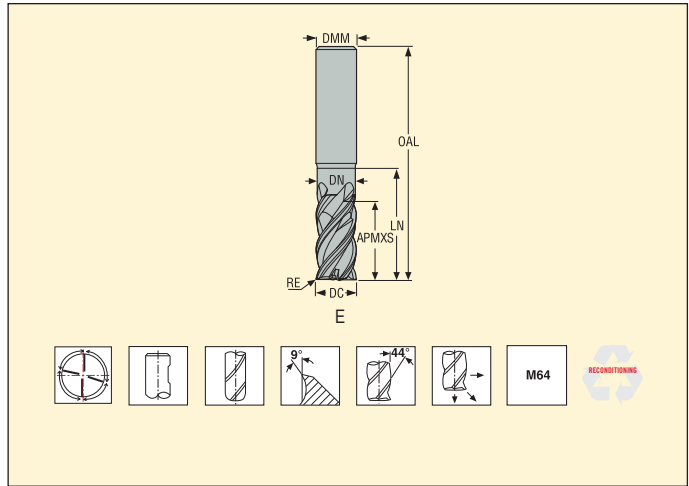

Ordering and Product No.	Designation	Length index	Tool shape	Dimensions in mm				LN	DN	RE	PCEDC	Weldon
				DC	DMM	APMXS	OAL					
02760894	JHP780200E2R040.3Z4-M64	2	E	20,0	20	40,0	115	55,0	19,4	0,4	4	■
02760896	JHP780200E2R080.3Z4-M64	2	E	20,0	20	40,0	115	55,0	19,4	0,8	4	■
02760900	JHP780250E2R040.3Z4-M64	2	E	25,0	25	50,0	130	65,0	24,4	0,4	4	■
02760901	JHP780250E2R080.3Z4-M64	2	E	25,0	25	50,0	130	65,0	24,4	0,8	4	■
02760903	JHP780250E2R400.3Z4-M64	2	E	25,0	25	50,0	130	65,0	24,4	4,0	4	■
03093709	JHP780250E2R600.3Z4-M64	2	E	25,0	25	50,0	130	65,0	24,4	6,0	4	□
02760897	JHP780200E2R310.3Z4-M64	2	E	20,0	20	40,0	115	55,0	19,4	3,1	4	■
02760898	JHP780200E2R400.3Z4-M64	2	E	20,0	20	40,0	115	55,0	19,4	4,0	4	■
03093719	JHP780200E2R600.3Z4-M64	2	E	20,0	20	40,0	115	55,0	19,4	6,0	4	□

■ Stock standard. Subject to change refer to current price- and stock-list □ Weldon available, delivery time is 3 days.

JHP780 – High performance – Superalloy – Square – 4 Flutes – Safelock



Tolerances:

DMM= h5

DC= e7

RE= $\pm 0,02$ mm

Regrind possible if DC is $\geq \varnothing 6$

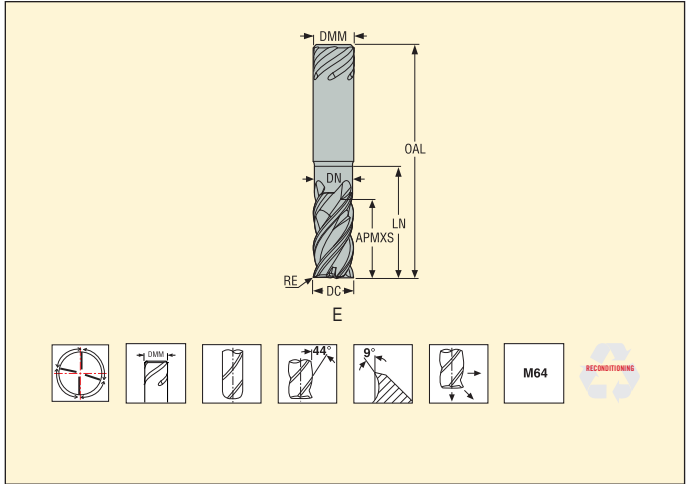

Ordering and Product No.	Designation	Length index	Tool shape	Dimensions in mm				LN	DN	RE	PCEDC	Safelock
				DC	DMM	APMXS	OAL					
03093718	JHP780160E2R600.9Z4-M64	2	E	16,0	16	32,0	100	45,0	15,4	6,0	4	<input type="checkbox"/>
03093720	JHP780200E2R600.9Z4-M64	2	E	20,0	20	40,0	115	55,0	19,4	6,0	4	<input type="checkbox"/>
03093710	JHP780250E2R600.9Z4-M64	2	E	25,0	25	50,0	130	65,0	24,4	6,0	4	<input type="checkbox"/>

■ Stock standard. Subject to change refer to current price- and stock-list

Cutting data – JHP780 Slot milling

SMG		a_p/DC	f_z									v_c
			6	8	10	12	14	16	20	25		
S1	E	0,80	0,020	0,028	0,034	0,042	0,048	0,055	0,070	0,085	44 (37 – 50)	
S2	E	0,80	0,020	0,028	0,034	0,042	0,048	0,055	0,070	0,085	35 (30 – 40)	
S3	E	0,60	0,012	0,016	0,020	0,024	0,028	0,032	0,040	0,050	25 (20 – 30)	

Cutting data – JHP780 Side milling

SMG		a_e/DC	a_p/DC	f_z									v_c
				6	8	10	12	14	16	20	25		
S1	E	0,30	1,0	0,036	0,048	0,060	0,070	0,080	0,090	0,10	0,12	50 (45 – 60)	
S2	E	0,30	1,0	0,036	0,048	0,060	0,070	0,080	0,090	0,10	0,12	42 (36 – 48)	
S3	E	0,30	0,80	0,036	0,048	0,060	0,070	0,080	0,090	0,10	0,11	28 (22 – 33)	

For cutting data recalculations, see page 411-418.

SMG = Seco material group

Coolant = A=air D=dry E=emulsion M=mist spray

v_c = m/min

f_z = mm

a_p (mm)/DC (mm) = factor

a_e (mm)/DC (mm) = factor

All cutting data are target values

JH770 – High speed – CoCr/Titanium – Square – 3-4-5-6 Flutes – Cylindrical – Corner radius



Tolerances:
 DMM= h5
 DC= e7
 RE= ±0,02 mm
 Regrind possible if DC is ≥Ø6

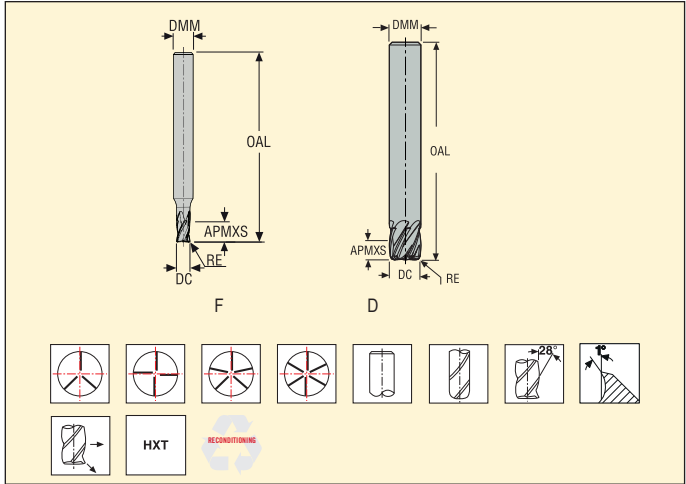

Ordering and Product No.	Designation	Length index	Tool shape	Dimensions in mm				RE	PCEDC	Cylindrical
				DC	DMM	APMXS	OAL			
03320783	JH770030F2R020.0Z3-HXT	2	F	3,0	6	5	58	0,2	3	■
03320784	JH770040F2R020.0Z4-HXT	2	F	4,0	6	6	58	0,2	4	■
10000170	JH770050F2R020.0Z4-HXT	2	F	5,0	6	7	58	0,2	4	■
03127351	JH770060D2R050.0Z4-HXT	2	D	6,0	6	8	50	0,5	4	■
03127352	JH770080D2R050.0Z4-HXT	2	D	8,0	8	10	58	0,5	4	■
03127354	JH770080D2R050.0Z5-HXT	2	D	8,0	8	10	58	0,5	5	■
03127353	JH770080D2R100.0Z4-HXT	2	D	8,0	8	10	58	1,0	4	■
03127355	JH770080D2R100.0Z5-HXT	2	D	8,0	8	10	58	1,0	5	■
03127356	JH770080D2R100.0Z6-HXT	2	D	8,0	8	10	58	1,0	6	■
03127357	JH770100D2R100.0Z5-HXT	2	D	10,0	10	12	66	1,0	5	■
03127358	JH770100D2R100.0Z6-HXT	2	D	10,0	10	12	66	1,0	6	■

■ Stock standard. Subject to change refer to current price- and stock-list

Cutting data – JH770 Side milling roughing PCEDC 3 and 4

SMG		a _e /DC	a _p /DC	f _z				
				3	4	6	8	
S2	E	0,75	0,12	0,015	0,020	0,030	0,040	v _c 50 (42 – 62)
S11	E	0,25	0,32	0,0075	0,010	0,015	0,020	65 (53 – 91)
S12	E	0,25	0,32	0,0075	0,010	0,015	0,020	50 (41 – 70)

Cutting data – JH770 Side milling roughing PCEDC 5

SMG		a _e /DC	a _p /DC	f _z		
				8	10	
S2	E	0,75	0,13	0,040	0,048	v _c 50 (41 – 60)
S11	E	0,25	0,31	0,020	0,024	65 (50 – 90)
S12	E	0,25	0,31	0,020	0,024	50 (40 – 70)

Cutting data – JH770 Side milling roughing PCEDC 6

SMG		a _e /DC	a _p /DC	f _z		
				8	10	
S2	E	0,75	0,13	0,050	0,060	v _c 55 (43 – 65)
S11	E	0,25	0,31	0,022	0,026	65 (55 – 95)
S12	E	0,25	0,31	0,022	0,026	50 (41 – 70)

For cutting data recalculations, see page 411-418.

SMG = Seco material group

Coolant = A=air D=dry E=emulsion M=mist spray

v_c = m/min

f_z = mm

a_p (mm)/DC (mm)= factor

a_e (mm)/DC (mm)= factor

All cutting data are target values

JH740 – High speed – CoCr/Titanium – Bottom finisher – 4-5 Flutes – Cylindrical – Corner radius

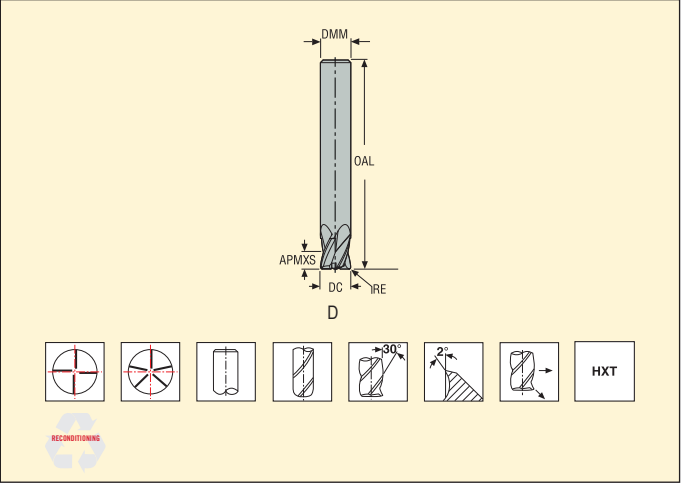

Tolerances:
DMM=h5
DC=e7
RE= ±0,02 mm
Regrind possible if DC is ≥Ø6

Table with 11 columns: Ordering and Product No., Designation, Length index, Tool shape, Dimensions in mm (DC, DMM, APMXS, OAL), RE, PCEDC, Cylindrical. Contains 5 data rows and empty rows below.

■ Stock standard. Subject to change refer to current price- and stock-list

Cutting data – JH740 Face finishing PCEDC 4

SMG		a_e/DC	a_p/DC	f_z		 v_c
				6	8	
S2	E	0,50	0,0063	0,044	0,060	50 (40 – 60)
S11	E	0,50	0,0063	0,044	0,060	65 (50 – 80)
S12	E	0,50	0,0063	0,044	0,060	50 (40 – 60)

Cutting data – JH740 Face finishing PCEDC 5

SMG		a_e/DC	a_p/DC	f_z	 v_c
				10	
S2	E	0,50	0,0065	0,046	48 (39 – 60)
S11	E	0,50	0,0065	0,046	65 (50 – 75)
S12	E	0,50	0,0065	0,046	48 (39 – 60)

SMG = Seco material group

Coolant = A=air D=dry E=emulsion M=mist spray

v_c = m/min

f_z = mm

a_p (mm)/DC (mm)= factor

a_e (mm)/DC (mm)= factor

All cutting data are target values

JH710 – High speed – CoCr/Titanium – Square – 5 Flutes – Cylindrical – Corner radius



Tolerances:

DMM=h5

DC=e7

RE= ±0,02 mm

Regrind possible if DC is ≥Ø6

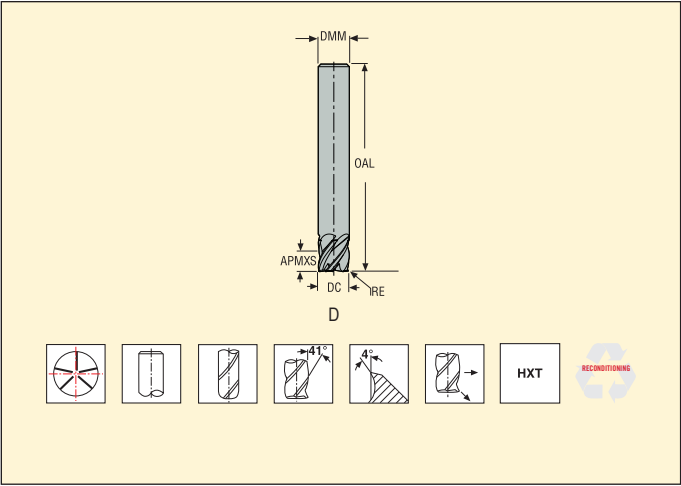

Ordering and Product No.	Designation	Length index	Tool shape	Dimensions in mm					PCEDC	Cylindrical
				DC	DMM	APMXS	OAL	RE		
03127365	JH710060D2R025.0Z5-HXT	2	D	6,0	6	6	57	0,25	5	■
03127366	JH710060D2R050.0Z5-HXT	2	D	6,0	6	6	57	0,5	5	■
03127367	JH710080D2R025.0Z5-HXT	2	D	8,0	8	8	63	0,25	5	■
03127368	JH710080D2R050.0Z5-HXT	2	D	8,0	8	8	63	0,5	5	■
03127369	JH710080D2R100.0Z5-HXT	2	D	8,0	8	8	63	1,0	5	■

■ Stock standard. Subject to change refer to current price- and stock-list

Cutting data – JH710 Side milling finishing

SMG		a_e/DC	a_p/DC	f_z		 v_c
				6	8	
S2	E	0,0081	0,63	0,034	0,044	100 (80 – 120)
S11	E	0,0081	0,63	0,036	0,046	180 (155 – 205)
S12	E	0,0081	0,63	0,036	0,046	135 (120 – 155)

SMG = Seco material group

Coolant = A=air D=dry E=emulsion M=mist spray

v_c = m/min

f_z = mm

a_p (mm)/DC (mm)= factor

a_e (mm)/DC (mm)= factor

All cutting data are target values

JH790 – High speed – CoCr/Titanium – T Cutter – 6 Flutes – Cylindrical



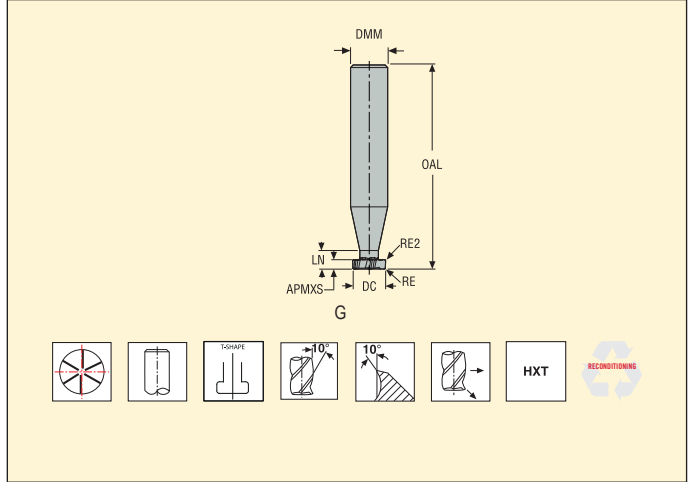

Tolerances:
 DMM=h5
 DC= $\pm 0,02$ mm
 RE= $\pm 0,02$ mm
 Re grind possible if DC is $\geq \varnothing 6$



Ordering and Product No.	Designation	Length index	Tool shape	Dimensions in mm					RE	RE2	PCEDC	Cylindrical
				DC	DMM	APMXS	OAL	LN				
03127370	JH790095G2R025.0Z6-HXT	2	G	9,5	10	2,00	66	5	0,25	0,25	6	■
03127371	JH790095G2R050.0Z6-HXT	2	G	9,5	10	2,00	66	5	0,5	0,5	6	■
03127372	JH790095G3R025.0Z6-HXT	3	G	9,5	10	2,54	66	5	0,25	0,25	6	■
03127373	JH790095G3R050.0Z6-HXT	3	G	9,5	10	2,54	66	5	0,5	0,5	6	■

■ Stock standard. Subject to change refer to current price- and stock-list

Cutting data – JH790 (T) Side milling roughing

SMG		a_e/DC	a_p/DC	f_z	
				9,5	v_c
S2	E	0,19	0,19	0,030	39 (30 – 50)
S11	E	0,19	0,19	0,022	85 (65 – 105)
S12	E	0,19	0,19	0,022	65 (50 – 80)

SMG = Seco material group

Coolant = A=air D=dry E=emulsion M=mist spray

v_c = m/min

f_z = mm

a_p (mm)/DC (mm)= factor

a_e (mm)/DC (mm)= factor

All cutting data are target values

JH730 – High speed – CoCr/Titanium – Square – 6-7 Flutes – Cylindrical – Corner radius

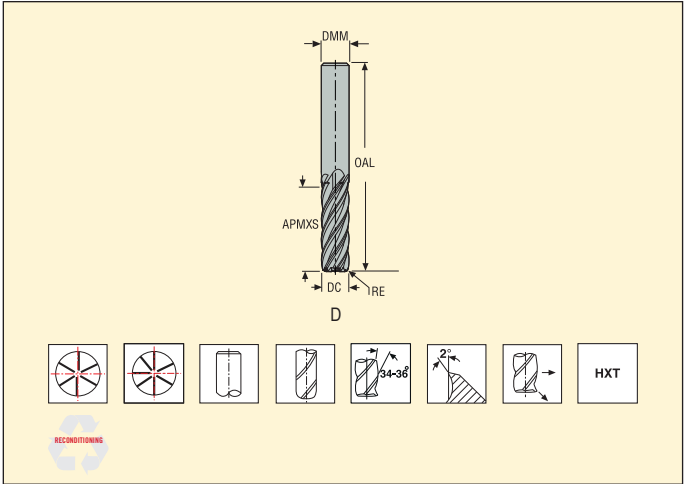

Tolerances:

DMM=h5

DC=e7

RE= ±0,02 mm

Regrind possible if DC is ≥∅6

Ordering and Product No.	Designation	Length index	Tool shape	Dimensions in mm				RE	PCEDC	Cylindrical
				DC	DMM	APMXS	OAL			
03127375	JH730080D2R050.0Z6-HXT	2	D	8,0	8	25	63	0,5	6	■
03127377	JH730080D2R100.0Z6-HXT	2	D	8,0	8	25	63	1,0	6	■
03127378	JH730080D2R150.0Z6-HXT	2	D	8,0	8	25	63	1,5	6	■
03127379	JH730080D2R200.0Z6-HXT	2	D	8,0	8	25	63	2,0	6	■
03127380	JH730100D2R100.0Z7-HXT	2	D	10,0	10	31	72	1,0	7	■
03127381	JH730100D2R250.0Z7-HXT	2	D	10,0	10	31	72	2,5	7	■

■ Stock standard. Subject to change refer to current price- and stock-list

Cutting data – JH730 Side milling finishing

SMG		a_p/DC	a_e/DC	f_z		 v_c
				8	10	
S2	E	0,063	1,8	0,020	0,026	80 (60 – 95)
S11	E	0,063	1,8	0,016	0,020	135 (105 – 160)
S12	E	0,063	1,8	0,016	0,020	105 (80 – 125)

For cutting data recalculations, see page 411-418.

SMG = Seco material group

Coolant = A=air D=dry E=emulsion M=mist spray

v_c = m/min

f_z = mm

a_p (mm)/DC (mm)= factor

a_e (mm)/DC (mm)= factor

All cutting data are target values

JHP994 - High performance - CoCr/Titanium - Square - 4 Flutes - Cylindrical - Chamfer



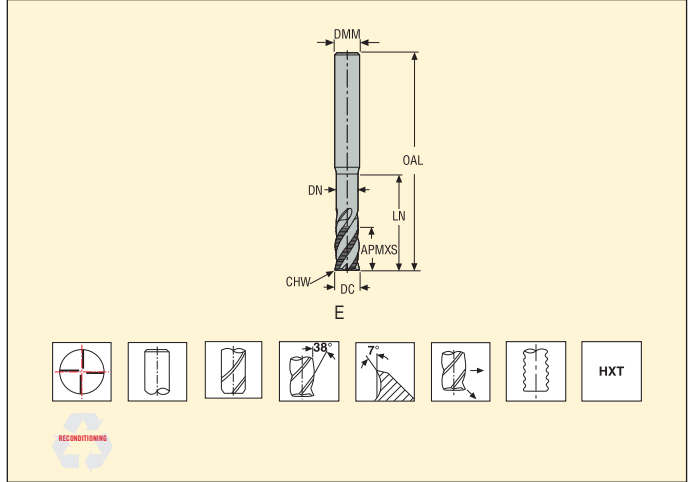

Tolerances:
DMM=h5
DC= -0,02/-0,1 mm
CHW=0/-0,1 mm
Regrind possible if DC is $\geq \varnothing 6$



Ordering and Product No.	Designation	Length index	Tool shape	Dimensions in mm							PCEDC	Cylindrical
				DC	DMM	APMXS	OAL	LN	DN	CHW		
03127382	JHP994060E3C.0Z4-HXT	3	E	6,0	6	14	63	24	5,6	0,2	4	■
03127383	JHP994080E3C.0Z4-HXT	3	E	8,0	8	18	69	32	7,4	0,2	4	■
03127384	JHP994100E3C.0Z4-HXT	3	E	10,0	10	22	88	40	9,4	0,2	4	■

■ Stock standard. Subject to change refer to current price- and stock-list

Cutting data - JHP994 Side milling roughing

SMG		a_e/DC	a_p/DC	f_z		 v_c
				8	10	
S2	E	0,048	2,0	0,030	0,036	55 (40 — 70)
S11	E	0,44	0,63	0,034	0,042	50 (39 — 80)
S12	E	0,44	0,63	0,034	0,042	40 (30 — 60)

SMG = Seco material group

Coolant = A=air D=dry E=emulsion M=mist spray

v_c = m/min

f_z = mm

a_p (mm)/DC (mm)= factor

a_e (mm)/DC (mm)= factor

All cutting data are target values

JH780 – High speed – CoCr/Titanium – Tapered ball nose – 4 Flutes – Cylindrical



Tolerances:

DMM=h5

DC= ±0,04 mm

RE= ±0,01 mm

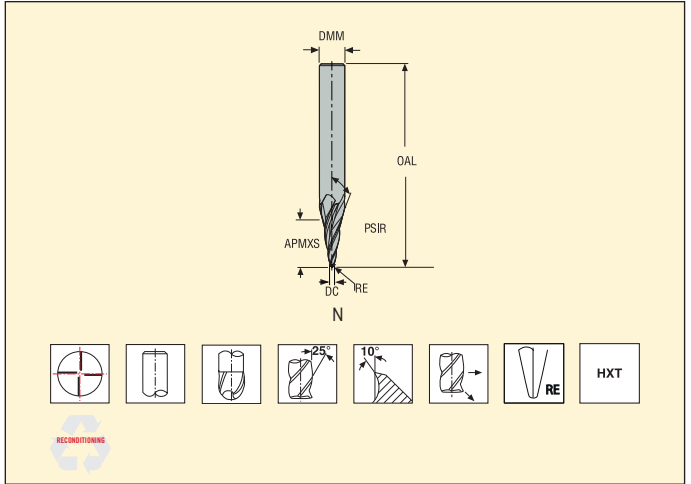

Regrind possible if DMM is ≥Ø6



Ordering and Product No.	Designation	Length index	Tool shape	Dimensions in mm				RE	PSIR	PCEDC	Cylindrical
				DC	DMM	APMXS	OAL				
03127386	JH780018N2R100.0Z4-HXT	2	N	1,827	8	23,5	63	1,0	5,18	4	■
03127387	JH780028N2R150.0Z4-HXT	2	N	2,803	8	23,5	63	1,5	3,89	4	■
03127388	JH780038N2R200.0Z4-HXT	2	N	3,823	8	23,5	63	2,0	2,60	4	■
03127389	JH780049N2R250.0Z4-HXT	2	N	4,888	8	23,5	63	2,5	1,30	4	■

■ Stock standard. Subject to change refer to current price- and stock-list

Cutting data – JH780 Copy milling

SMG		a_e/DC	a_p/DC	f_z				
				1,8	2,8	3,8	4,9	
S2	E	0,049	4,3	0,0075	0,012	0,016	0,020	65 (50 — 85)
S12	E	0,049	4,3	0,0055	0,0085	0,012	0,015	90 (70 — 115)

For cutting data recalculations, see page 411-418.

SMG = Seco material group

Coolant = A=air D=dry E=emulsion M=mist spray

v_c = m/min

f_z = mm

a_p (mm)/DC (mm)= factor

a_e (mm)/DC (mm)= factor

All cutting data are target values

JH720 - High speed - Titanium - Ball nose - 3 Flutes - Cylindrical



Tolerances:
 DMM=h5
 DC=-0,02/-0,04 mm
 RE= ±0,01 mm
 Regrind possible if DC is ≥Ø6

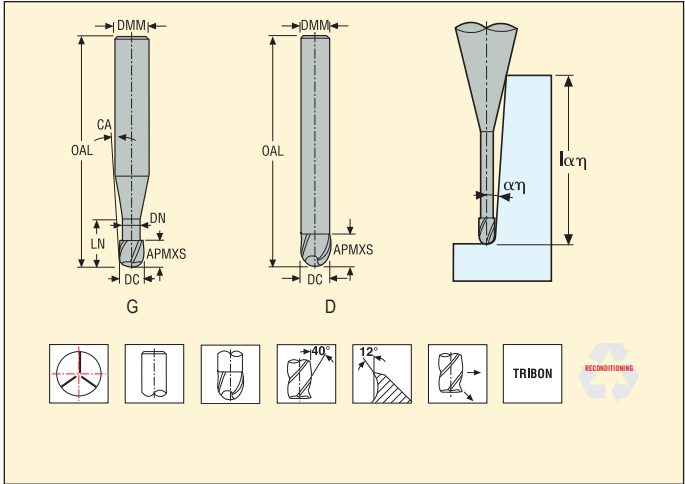

Ordering and Product No.	Designation	Length index	Tool shape	Dimensions in mm								P/CEDC	Max. cut depth rel. to αη (lαη, ref)*					
				DC	DMM	APMXS	OAL	LN	LN2	DN	CA		WDX0	WDX05	WDX1	WDX15	WDX2	WDX3
00019845	720020-TRIBON	2	G	2,0	6	3,0	60	6,0	18,1	1,9	7,0	3	6,5	7,0	7,4	7,7	8,2	9,2
00019867	720025-TRIBON	2	G	2,5	6	4,0	60	6,0	16,7	2,4	6,5	3	6,5	7,0	7,3	7,7	8,1	9,1
00019906	720030-TRIBON	2	G	3,0	6	4,5	60	6,5	19,1	2,8	5,0	3	7,0	8,2	8,7	9,3	10,0	11,9
00019909	720035-TRIBON	2	G	3,5	6	5,0	65	7,0	23,5	3,2	3,5	3	7,5	10,0	11,0	12,4	14,1	20,4
00019918	720040-TRIBON	2	G	4,0	6	6,0	65	8,0	21,6	3,7	3,0	3	8,5	11,1	12,2	13,7	15,6	∞
00019965	720050-TRIBON	2	G	5,0	6	7,5	65	10,0	18,5	4,6	2,0	3	10,5	13,9	15,3	17,1	∞	∞
00019990	720060-TRIBON	2	D	6,0	6	9,0	75	-	-	-	-	3	9,0	∞	∞	∞	∞	∞
00020040	720080-TRIBON	2	D	8,0	8	12,0	75	-	-	-	-	3	12,0	∞	∞	∞	∞	∞
00020043	720100-TRIBON	2	D	10,0	10	15,0	80	-	-	-	-	3	15,0	∞	∞	∞	∞	∞
00020045	720120-TRIBON	2	D	12,0	12	18,0	90	-	-	-	-	3	18,0	∞	∞	∞	∞	∞
00020048	720160-TRIBON	2	D	16,0	16	24,0	100	-	-	-	-	3	24,0	∞	∞	∞	∞	∞

* The effective under -neck length for the various draft angles. Remark ∞ = infinity, no collision in projection length area.

Cutting data – JH720 Side milling roughing

SMG		a _e /DC	a _p /DC	f _z													v _c
				2	2,5	3	3,5	4	5	6	8	10	12	16			
M1	M/E/A	0,20	1,2	0,0080	0,010	0,012	0,014	0,016	0,020	0,024	0,032	0,040	0,048	0,060	85 (62 – 110)		
M2	M/E/A	0,20	1,2	0,0070	0,0090	0,011	0,013	0,014	0,018	0,022	0,028	0,036	0,044	0,055	70 (51 – 91)		
M3	M/E/A	0,20	1,2	0,0080	0,010	0,012	0,014	0,016	0,020	0,024	0,032	0,040	0,048	0,060	65 (46 – 84)		
M4	M/E/A	0,20	0,90	0,0075	0,0095	0,011	0,013	0,015	0,018	0,022	0,030	0,036	0,044	0,055	50 (36 – 66)		
M5	M/E/A	0,20	0,90	0,0075	0,0095	0,011	0,013	0,015	0,018	0,022	0,030	0,036	0,044	0,055	42 (30 – 55)		
N1	E/M/A	0,40	1,2	0,020	0,025	0,030	0,036	0,040	0,050	0,060	0,080	0,10	0,12	0,15	600 (500 – 690)		
N2	E/M/A	0,40	1,2	0,016	0,020	0,024	0,028	0,032	0,040	0,048	0,065	0,080	0,095	0,12	500 (400 – 600)		
N11	E/M/A	0,30	1,2	0,012	0,015	0,018	0,022	0,024	0,030	0,036	0,048	0,060	0,070	0,090	300 (260 – 340)		
S1	E/M/A	0,10	1,2	0,0065	0,0080	0,0095	0,011	0,013	0,016	0,019	0,026	0,032	0,038	0,048	43 (29 – 57)		
S2	E/M/A	0,10	1,2	0,0065	0,0080	0,0095	0,011	0,013	0,016	0,019	0,026	0,032	0,038	0,048	35 (24 – 46)		
S3	E/M/A	0,10	1,2	0,0060	0,0075	0,0090	0,011	0,012	0,015	0,018	0,024	0,030	0,036	0,044	30 (21 – 39)		
S11	E/M/A	0,30	1,2	0,010	0,013	0,015	0,018	0,020	0,025	0,030	0,040	0,050	0,060	0,075	90 (79 – 100)		
S12	E/M/A	0,30	1,2	0,010	0,013	0,015	0,018	0,020	0,025	0,030	0,040	0,050	0,060	0,075	70 (61 – 80)		
S13	E/M/A	0,30	1,0	0,0090	0,011	0,014	0,016	0,018	0,022	0,028	0,036	0,046	0,055	0,065	55 (49 – 64)		
TS1	A	0,40	1,2	0,020	0,025	0,030	0,036	0,040	0,050	0,060	0,080	0,10	0,12	0,15	500 (400 – 600)		
TP1	M	0,40	1,2	0,020	0,025	0,030	0,036	0,040	0,050	0,060	0,080	0,10	0,12	0,15	500 (400 – 600)		

For cutting data recalculations, see page 411-418.

SMG = Seco material group

Coolant = A=air D=dry E=emulsion M=mist spray

v_c = m/min



f_z = mm

a_p (mm)/DC (mm)= factor

a_e (mm)/DC (mm)= factor

All cutting data are target values

Cutting data – JH72I Copy milling finishing

SMG		a_e/DC	a_p/DC	f_z		 v_c
				6	6	
S2	E	0,043	0,040	0,022	0,022	120 (100 – 140)
S11	E	0,043	0,040	0,022	0,022	210 (130 – 235)
S12	E	0,043	0,040	0,022	0,022	160 (100 – 180)

SMG = Seco material group

Coolant = A=air D=dry E=emulsion M=mist spray

v_c = m/min



f_z = mm

a_p (mm)/DC (mm)= factor

a_e (mm)/DC (mm)= factor

All cutting data are target values

Cutting data – JH722 Copy milling finishing

SMG		a_e/DC	a_p/DC	f_z	
				10	v_c
S2	E	0,050	0,15	0,040	130 (105 – 155)
S11	E	0,050	0,15	0,030	215 (185 – 240)
S12	E	0,050	0,15	0,030	165 (145 – 185)

SMG = Seco material group

Coolant = A=air D=dry E=emulsion M=mist spray

v_c = m/min

f_z = mm

a_p (mm)/DC (mm)= factor

a_e (mm)/DC (mm)= factor

All cutting data are target values

JCO710 - High performance - Titanium - Square - 4-6 Flutes - Weldon - Corner radius

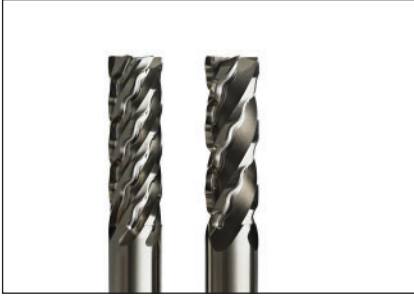

Tolerances:
 DMM= h6
 DC= k10
 RE= ±0,05 mm
 Regrind possible if DC is ≥Ø6

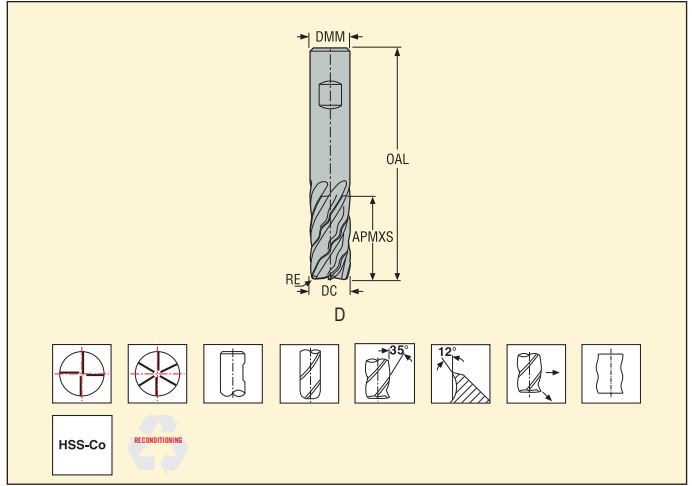

Ordering and Product No.	Designation	Length index	Tool shape	Dimensions in mm				RE	PCEDC	Weldon
				DC	DMM	APMXS	OAL			
02810493	JCO710160D2R100.3Z4	2	D	16,0	16	32	92	1,0	4	■
02810494	JCO710160D2R250.3Z4	2	D	16,0	16	32	92	2,5	4	■
02810496	JCO710160D2R400.3Z4	2	D	16,0	16	32	92	4,0	4	■
02810497	JCO710200D2R100.3Z4	2	D	20,0	20	38	114	1,0	4	■
02810498	JCO710200D2R250.3Z4	2	D	20,0	20	38	114	2,5	4	■
02810500	JCO710200D2R400.3Z4	2	D	20,0	20	38	114	4,0	4	■
02905391	JCO710250D2R400.3Z4	2	D	25,0	25	45	121	4,0	4	■
02905392	JCO710320D2R100.3Z4	2	D	32,0	32	53	132	1,0	4	■
02905393	JCO710320D2R400.3Z4	2	D	32,0	32	53	132	4,0	4	■
02810501	JCO710250D2R100.3Z6	2	D	25,0	25	45	121	1,0	6	■
02810503	JCO710250D2R400.3Z6	2	D	25,0	25	45	121	4,0	6	■
02810504	JCO710320D2R100.3Z6	2	D	32,0	32	53	132	1,0	6	■
02810505	JCO710320D2R400.3Z6	2	D	32,0	32	53	132	4,0	6	■
02810506	JCO710400D2R100.3Z6	2	D	40,0	40	63	155	1,0	6	■
02810507	JCO710400D2R400.3Z6	2	D	40,0	40	63	155	4,0	6	■

■ Stock standard. Subject to change refer to current price- and stock-list

JCO710 - High performance - Titanium - Square - 4-6 Flutes - Weldon - Corner radius

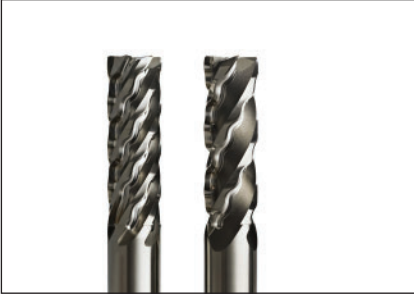

Tolerances:
 DMM= h6
 DC= k10
 RE= ±0,05 mm
 Regrind possible if DC is ≥Ø6

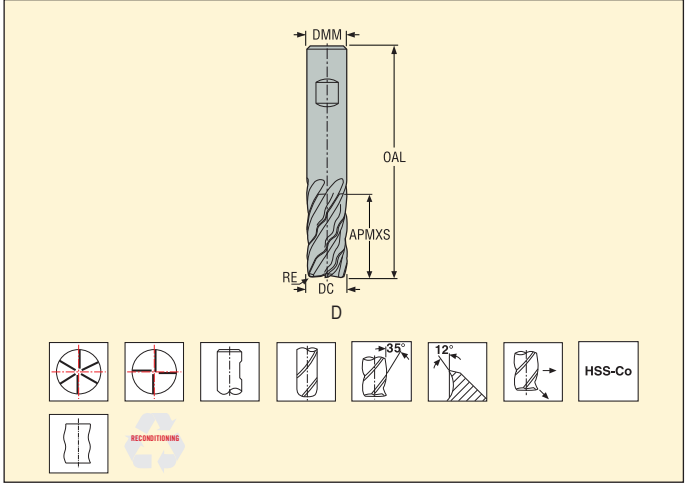

Ordering and Product No.	Designation	Length index	Tool shape	Dimensions in mm				RE	PCEDC	Weldon
				DC	DMM	APMXS	OAL			
02905373	JCO710160D4R100.3Z4	4	D	16,0	16	65	127	1,0	4	■
02905375	JCO710160D4R400.3Z4	4	D	16,0	16	65	127	4,0	4	■
02905376	JCO710200D4R100.3Z6	4	D	20,0	20	80	146	1,0	6	■
02905377	JCO710200D4R250.3Z6	4	D	20,0	20	80	146	2,5	6	■
02905379	JCO710250D4R100.3Z6	4	D	25,0	25	110	178	1,0	6	■
02905380	JCO710250D4R250.3Z6	4	D	25,0	25	110	178	2,5	6	■
02905381	JCO710250D4R400.3Z6	4	D	25,0	25	110	178	4,0	6	■
02905385	JCO710400D4R400.3Z6	4	D	40,0	40	160	240	4,0	6	■

■ Stock standard. Subject to change refer to current price- and stock-list.

JCO710 – High performance – Titanium – Square – 4-6 Flutes – Weldon – Corner radius



Tolerances:

DMM= h6

DC= k10

RE= ±0,05 mm

Regrind possible if DC is ≥06

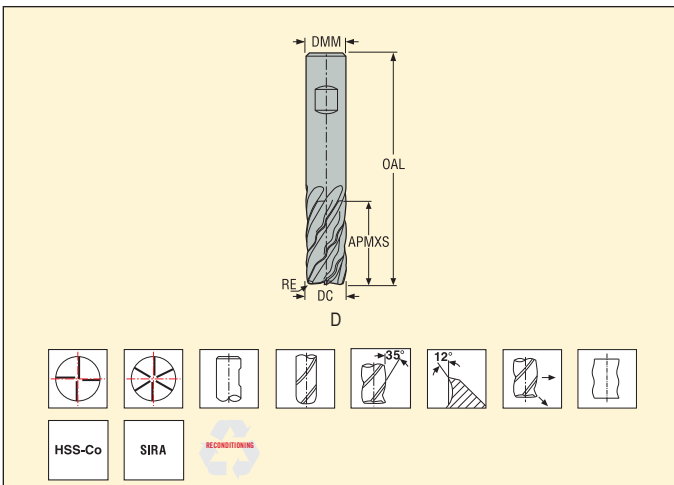

Ordering and Product No.	Designation	Length index	Tool shape	Dimensions in mm				RE	PCEDC	Weldon
				DC	DMM	APMXS	OAL			
03094462	JCO710160D2R100.3Z4-SIRA	2	D	16,0	16	32	92	1,0	4	<input type="checkbox"/>
03094463	JCO710160D2R250.3Z4-SIRA	2	D	16,0	16	32	92	2,5	4	<input type="checkbox"/>
03094465	JCO710160D2R400.3Z4-SIRA	2	D	16,0	16	32	92	4,0	4	<input type="checkbox"/>
03094469	JCO710200D2R100.3Z4-SIRA	2	D	20,0	20	38	114	1,0	4	<input type="checkbox"/>
03094470	JCO710200D2R250.3Z4-SIRA	2	D	20,0	20	38	114	2,5	4	<input type="checkbox"/>
03094472	JCO710200D2R400.3Z4-SIRA	2	D	20,0	20	38	114	4,0	4	<input type="checkbox"/>
03094481	JCO710250D2R400.3Z4-SIRA	2	D	25,0	25	45	121	4,0	4	<input type="checkbox"/>
03094486	JCO710320D2R100.3Z4-SIRA	2	D	32,0	32	53	132	1,0	4	<input type="checkbox"/>
03094488	JCO710320D2R400.3Z4-SIRA	2	D	32,0	32	53	132	4,0	4	<input type="checkbox"/>
03094477	JCO710250D2R100.3Z6-SIRA	2	D	25,0	25	45	121	1,0	6	<input type="checkbox"/>
03094482	JCO710250D2R400.3Z6-SIRA	2	D	25,0	25	45	121	4,0	6	<input type="checkbox"/>
03094487	JCO710320D2R100.3Z6-SIRA	2	D	32,0	32	53	132	1,0	6	<input type="checkbox"/>
03094489	JCO710320D2R400.3Z6-SIRA	2	D	32,0	32	53	132	4,0	6	<input type="checkbox"/>
03094492	JCO710400D2R100.3Z6-SIRA	2	D	40,0	40	63	155	1,0	6	<input type="checkbox"/>
03094493	JCO710400D2R400.3Z6-SIRA	2	D	40,0	40	63	155	4,0	6	<input type="checkbox"/>

■ Stock standard. Subject to change refer to current price- and stock-list Weldon available, delivery time is 3 days.

JCO710 - High performance - Titanium - Square - 4-6 Flutes - Weldon - Corner radius



Tolerances:
 DMM= h6
 DC= k10
 RE= ±0,05 mm
 Regrind possible if DC is ≥Ø6

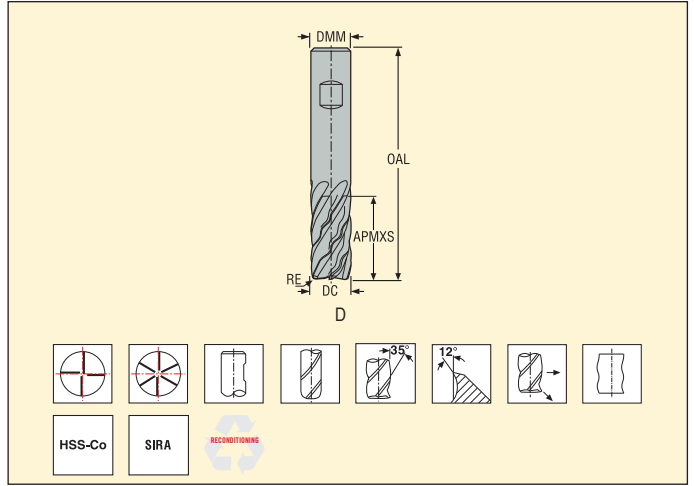

Ordering and Product No.	Designation	Length index	Tool shape	Dimensions in mm				RE	PCEDC	Weldon
				DC	DMM	APMXS	OAL			
03094466	JCO710160D4R100.3Z4-SIRA	4	D	16,0	16	65	127	1,0	4	<input type="checkbox"/>
03094468	JCO710160D4R400.3Z4-SIRA	4	D	16,0	16	65	127	4,0	4	<input type="checkbox"/>
03094473	JCO710200D4R100.3Z6-SIRA	4	D	20,0	20	80	146	1,0	6	<input type="checkbox"/>
03094474	JCO710200D4R250.3Z6-SIRA	4	D	20,0	20	80	146	2,5	6	<input type="checkbox"/>
03094483	JCO710250D4R100.3Z6-SIRA	4	D	25,0	25	110	178	1,0	6	<input type="checkbox"/>
03094484	JCO710250D4R250.3Z6-SIRA	4	D	25,0	25	110	178	2,5	6	<input type="checkbox"/>
03094485	JCO710250D4R400.3Z6-SIRA	4	D	25,0	25	110	178	4,0	6	<input type="checkbox"/>
03094495	JCO710400D4R400.3Z6-SIRA	4	D	40,0	40	160	240	4,0	6	<input type="checkbox"/>

■ Stock standard. Subject to change refer to current price- and stock-list Weldon available, delivery time is 3 days.

Cutting data – JCO710 Slot milling PCEDC4 LV2

SMG		a _p /DC	f _z						v _c
			16	20	25	32	40	50	
M1	E	1,0	0,055	0,065	0,080	0,11	0,13	0,16	20 (14 – 27)
M2	E	1,0	0,055	0,065	0,080	0,11	0,13	0,15	17 (11 – 22)
M3	E	0,50	0,046	0,055	0,070	0,090	0,11	0,14	11 (8 – 17)
M4	E	0,38	0,046	0,055	0,070	0,090	0,10	0,12	9 (6 – 13)
M5	E	0,38	0,046	0,055	0,070	0,090	0,10	0,12	7 (5 – 11)
S11	E	0,75	0,046	0,055	0,070	0,090	0,11	0,14	12 (9 – 18)
S12	E	0,75	0,046	0,055	0,070	0,090	0,11	0,14	9 (7 – 14)
S13	E	0,63	0,046	0,055	0,070	0,090	0,11	0,13	7 (5 – 11)

Cutting data – JCO710 Side milling roughing PCEDC4 LV2

SMG		a _e /DC	a _p /DC	f _z						v _c
				16	20	25	32	40	50	
M1	E	0,50	1,3	0,065	0,080	0,10	0,12	0,15	0,17	23 (16 – 31)
M2	E	0,50	1,3	0,060	0,075	0,090	0,11	0,13	0,15	19 (13 – 26)
S11	E	0,50	1,1	0,060	0,070	0,090	0,11	0,13	0,15	13 (10 – 20)
S12	E	0,50	1,1	0,060	0,070	0,090	0,11	0,13	0,15	10 (8 – 15)
S13	E	0,50	0,88	0,050	0,065	0,080	0,10	0,12	0,13	8 (6 – 12)

Cutting data – JCO710 Side milling roughing PCEDC6 LV4

SMG		a _p /DC	a _p /DC	f _z						v _c
				16	20	25	32	40	50	
M1	E	0,10	3,1	0,034	0,042	0,048	0,055	0,065	0,070	19 (13 – 25)
M2	E	0,10	3,1	0,030	0,038	0,044	0,050	0,060	0,065	16 (10 – 21)
S11	E	0,063	3,2	0,055	0,070	0,080	0,095	0,11	0,12	10 (8 – 15)
S12	E	0,063	3,2	0,055	0,070	0,080	0,095	0,11	0,12	8 (6 – 12)
S13	E	0,063	2,7	0,048	0,060	0,070	0,085	0,095	0,10	6 (5 – 9)

When JCO + SIRA is applied: v_c table * 1.2

For cutting data recalculations, see page 411-418.

SMG = Seco material group

Coolant = A=air D=dry E=emulsion M=mist spray

v_c = m/min

f_z = mm

a_p (mm)/DC (mm)= factor

a_e (mm)/DC (mm)= factor

























All cutting data are target values



Name		JS412	JS413	JS452	JS453	JHP490
Page(s)		265-267	268-270	271-275	276-280	281-284
Family name		JS ²	JS ²	JS ²	JS ²	HPM
Type of mill						
Shank	Cylindrical	■	■	■	■	■
	Weldon	■	■	□	□	■
Number of Flutes		2	3	2	3	2-3
ICC						■
Diameter range	Metric	2-20	2-20	2-20	2-20	10-25
	Inch					
Length availability		 2	 2,3	 2,3	 2,3	 2,3,4
Operation		 	 	 	 	
SMG						
N1		●	●	●	●	●
N2		●	●	●	●	●
N3			●	●	●	●
TS1		●	●	●	●	
TP1		●	●	●	●	

■ Stock standard □ Weldon available, delivery time is 3 days.

● Preferred choice ○ Alternative choice

					
					
Name		JH40	JH421	JH410	JH830
Page(s)		285-287	288-291	292-293	294-295
Family name		HSM/TORNADO	HSM/TORNADO	HSM/TORNADO	HSM/TORNADO
Type of mill					
Shank	Cylindrical	■	■	■	■
	Weldon				
Number of Flutes		2	2-3	1	3
ICC			■		
Diameter range	Metric	2-20	3-25	2-17	2-12
	Inch				
Length availability		 1,2	 2,3	 2,3	 2
Operation					
					
SMG					
N1		●	●	●	
N2					●
N3					●
N11		●	●	●	
TS1		●	●	●	
TP1			●		

■ Stock standard □ Weldon available, delivery time is 3 days.

● Preferred choice ○ Alternative choice

Name		JH440	JH450	JH460	JM403/404/406	JM413/416
Page(s)		296-297	298-299	300-301	302-303	304-305
Family name		HSM/TORNADO	HSM/TORNADO	HSM/TORNADO	MINI	MINI
Type of mill						
Shank	Cylindrical	■	■	■	■	■
	Weldon					
Number of Flutes		2	2	2	1	2
ICC						
Diameter range	Metric	6-16	2-20	3-12	0,2-2	0,5-2
	Inch					
Length availability						
		2	2,3	2	2	2,3
Operation						
SMG						
N1		●	●	●	●	●
N2		●	●		●	●
N3		●	●		●	●
N11		●	●	●		●
TS1		●	●	●		●
TP1		●	●	●		●

■ Stock standard □ Weldon available, delivery time is 3 days.

● Preferred choice ○ Alternative choice

Cutting data – JS412 Slot milling

SMG		a _p /DC	f _z										v _c
			2	3	4	5	6	8	10	12	16	20	
N1	E	1,2	0,020	0,030	0,040	0,050	0,060	0,080	0,10	0,12	0,16	0,20	500 (400 – 600)
N2	E	1,0	0,016	0,024	0,032	0,040	0,048	0,065	0,080	0,095	0,13	0,16	400 (300 – 500)
TS1	A	1,2	0,020	0,030	0,040	0,050	0,060	0,080	0,10	0,12	0,16	0,20	530 (420 – 630)
TP1	A	1,2	0,020	0,030	0,040	0,050	0,060	0,080	0,10	0,12	0,16	0,20	420 (315 – 530)

Cutting data – JS412 Side milling

SMG		a _e /DC	a _p /DC	f _z										v _c
				2	3	4	5	6	8	10	12	16	20	
N1	E/M/A	0,40	1,5	0,026	0,038	0,050	0,065	0,080	0,10	0,13	0,15	0,19	0,22	590 (470 – 700)
N2	E/M/A	0,30	1,4	0,026	0,040	0,050	0,065	0,080	0,10	0,13	0,16	0,19	0,22	475 (360 – 600)
TS1	A/D	0,40	1,5	0,026	0,038	0,050	0,065	0,080	0,10	0,13	0,15	0,19	0,22	620 (495 – 740)
TP1	A/D	0,40	1,5	0,026	0,038	0,050	0,065	0,080	0,10	0,13	0,15	0,19	0,22	495 (370 – 620)

For cutting data recalculations, see page 411-418.

SMG = Seco material group

Coolant = A=air D=dry E=emulsion M=mist spray

v_c = m/min

f_z = mm

a_p (mm)/DC (mm)= factor

a_e (mm)/DC (mm)= factor

All cutting data are target values

JS413 – General purpose – Aluminium – Square – 3 Flutes – Cylindrical – Sharp



Tolerances:

DMM= h5

DC= e8

Regrind possible if DC is $\geq \emptyset 6$

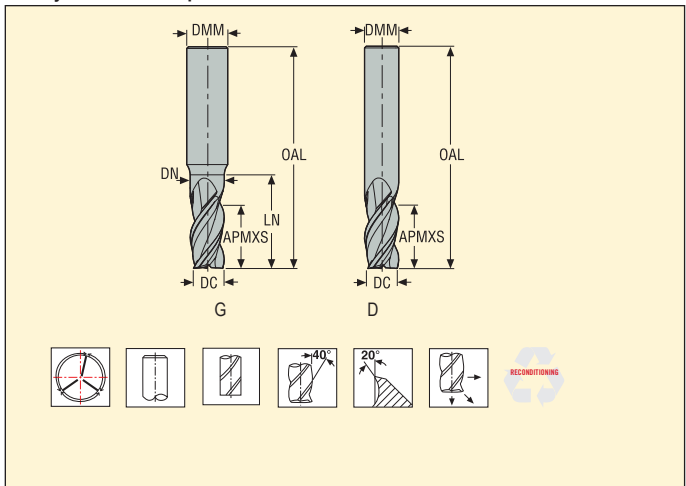

Ordering and Product No.	Designation	Length index	Tool shape	Dimensions in mm						PCEDC	Cylindrical
				DC	DMM	APMXS	OAL	LN	DN		
02881797	JS413020G2SZ3.0	2	G	2,0	6	4	57	7	1,9	3	■
02881798	JS413030G2SZ3.0	2	G	3,0	6	6	57	10	2,8	3	■
02881799	JS413040G2SZ3.0	2	G	4,0	6	8	57	14	3,8	3	■
02881800	JS413050G2SZ3.0	2	G	5,0	6	10	57	17	4,7	3	■
02881801	JS413060D2SZ3.0	2	D	6,0	6	12	57	–	–	3	■
02881802	JS413080D2SZ3.0	2	D	8,0	8	16	63	–	–	3	■
02881803	JS413100D2SZ3.0	2	D	10,0	10	20	72	–	–	3	■
02881804	JS413120D2SZ3.0	2	D	12,0	12	24	88	–	–	3	■
02881806	JS413160D2SZ3.0	2	D	16,0	16	32	100	–	–	3	■
02881807	JS413200D2SZ3.0	2	D	20,0	20	40	124	–	–	3	■
02881815	JS413060D3SZ3.0	3	D	6,0	6	24	70	–	–	3	■
02881816	JS413080D3SZ3.0	3	D	8,0	8	32	85	–	–	3	■
02881817	JS413100D3SZ3.0	3	D	10,0	10	40	100	–	–	3	■
02881818	JS413120D3SZ3.0	3	D	12,0	12	50	115	–	–	3	■
02881820	JS413160D3SZ3.0	3	D	16,0	16	55	125	–	–	3	■
02881821	JS413200D3SZ3.0	3	D	20,0	20	75	150	–	–	3	■

■ Stock standard. Subject to change refer to current price- and stock-list

JS413 – General purpose – Aluminium – Square – 3 Flutes – Weldon – Sharp



Tolerances:
 DMM= h5
 DC= e8
 Regrind possible if DC is ≥∅6

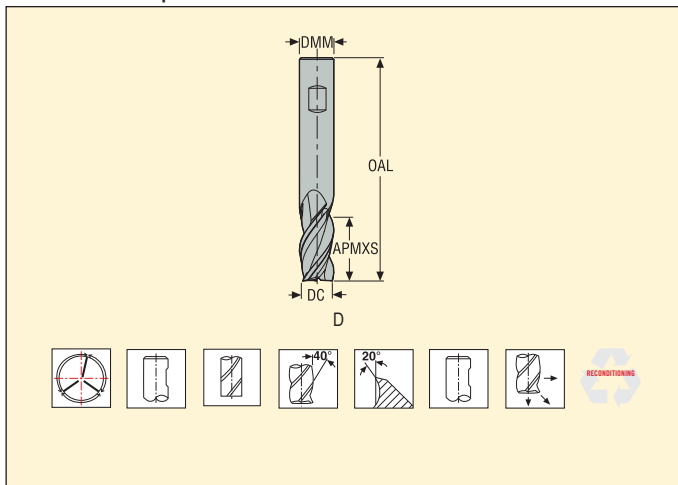

Ordering and Product No.	Designation	Length index	Tool shape	Dimensions in mm				PCEDC	Weldon
				DC	DMM	APMXS	OAL		
02881808	JS413060D2SZ3.3	2	D	6,0	6	12	57	3	■
02881809	JS413080D2SZ3.3	2	D	8,0	8	16	63	3	■
02881810	JS413100D2SZ3.3	2	D	10,0	10	20	72	3	■
02881811	JS413120D2SZ3.3	2	D	12,0	12	24	88	3	■
02881813	JS413160D2SZ3.3	2	D	16,0	16	32	100	3	■
02881814	JS413200D2SZ3.3	2	D	20,0	20	40	124	3	■
02881955	JS413060D3SZ3.3	3	D	6,0	6	24	70	3	□
02881956	JS413080D3SZ3.3	3	D	8,0	8	32	85	3	□
02881957	JS413100D3SZ3.3	3	D	10,0	10	40	100	3	□
02881958	JS413120D3SZ3.3	3	D	12,0	12	50	115	3	□
02881960	JS413160D3SZ3.3	3	D	16,0	16	55	125	3	□
02881961	JS413200D3SZ3.3	3	D	20,0	20	75	150	3	□

■ Stock standard. Subject to change refer to current price- and stock-list. □ Weldon available, delivery time is 3 days.

Cutting data – JS413 Slot milling

SMG		a _p /DC	f _z												v _c
			2	3	4	5	6	8	10	12	16	20			
N1	E	1,0	0,020	0,030	0,040	0,050	0,060	0,080	0,10	0,12	0,16	0,20	500 (400 – 600)		
N2	E	1,0	0,014	0,022	0,028	0,036	0,042	0,055	0,070	0,085	0,11	0,14	400 (300 – 500)		
N3	E	1,0	0,014	0,022	0,028	0,036	0,042	0,055	0,070	0,085	0,11	0,14	265 (200 – 335)		
TS1	A	1,0	0,020	0,030	0,040	0,050	0,060	0,080	0,10	0,12	0,16	0,20	340 (270 – 405)		
TP1	A	1,0	0,020	0,030	0,040	0,050	0,060	0,080	0,10	0,12	0,16	0,20	270 (205 – 340)		

Cutting data – JS413 Side milling

SMG		a _e /DC	a _p /DC	f _z												v _c
				2	3	4	5	6	8	10	12	16	20			
N1	E/M/A	0,40	1,5	0,024	0,036	0,048	0,060	0,070	0,095	0,12	0,14	0,18	0,20	600 (480 – 720)		
N2	E/M/A	0,30	1,5	0,024	0,036	0,048	0,060	0,070	0,095	0,12	0,14	0,18	0,20	470 (355 – 590)		
N3	E/M/A	0,30	1,5	0,024	0,036	0,048	0,060	0,070	0,095	0,12	0,14	0,18	0,20	315 (235 – 395)		
TS1	A/D	0,40	1,5	0,024	0,036	0,048	0,060	0,070	0,095	0,12	0,14	0,18	0,20	405 (325 – 485)		
TP1	A/D	0,40	1,5	0,024	0,036	0,048	0,060	0,070	0,095	0,12	0,14	0,18	0,20	325 (245 – 405)		

For cutting data recalculations, see page 411-418.

SMG = Seco material group

Coolant = A=air D=dry E=emulsion M=mist spray

v_c = m/min

f_z = mm

a_p (mm)/DC (mm)= factor

a_e (mm)/DC (mm)= factor

All cutting data are target values

JS452 – High performance – Aluminium – Square – 2 Flutes – Cylindrical – Corner radius or chamfer

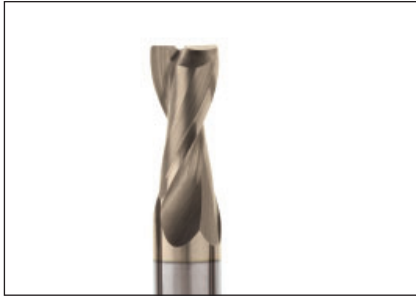

Tolerances:
 DMM= h5
 DC= e7
 RE= ±0,02
 CHW= +0,04 mm
 Regrind possible if DC is ≥Ø6

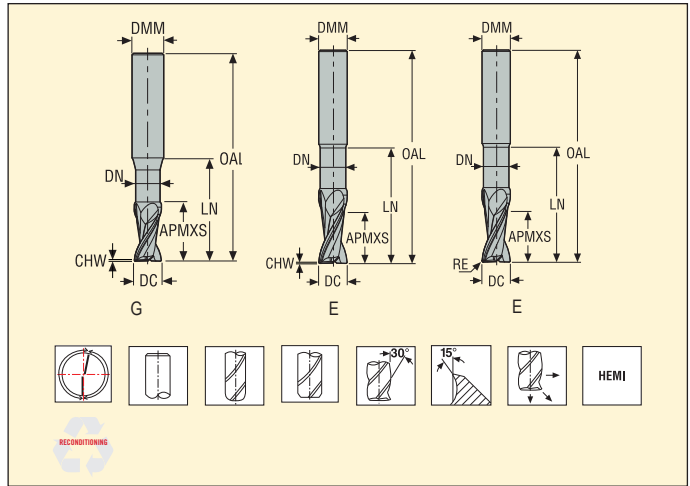

Ordering and Product No.	Designation	Length index	Tool shape	Dimensions in mm								RE	PCE/DC	Cylindrical
				DC	DMM	APMXS	OAL	LN	DN	CHW	RE			
02881848	JS452020G2CZ2.0-HEMI	2	G	2,0	6	4	57	8	1,9	0,1	-	2	■	
02881849	JS452030G2CZ2.0-HEMI	2	G	3,0	6	6	57	10	2,8	0,1	-	2	■	
02881850	JS452040G2CZ2.0-HEMI	2	G	4,0	6	8	57	14	3,8	0,1	-	2	■	
02881851	JS452050G2CZ2.0-HEMI	2	G	5,0	6	8	57	17	4,7	0,1	-	2	■	
02881852	JS452060E2CZ2.0-HEMI	2	E	6,0	6	12	57	19	5,7	0,1	-	2	■	
02881778	JS452080E2CZ2.0-HEMI	2	E	8,0	8	16	63	24	7,6	0,1	-	2	■	
02881856	JS452100E2CZ2.0-HEMI	2	E	10,0	10	20	72	29	9,5	0,1	-	2	■	
02881859	JS452120E2CZ2.0-HEMI	2	E	12,0	12	24	88	37	11,4	0,1	-	2	■	
02881862	JS452140E2CZ2.0-HEMI	2	E	14,0	14	28	88	41	13,3	0,1	-	2	■	
02881863	JS452160E2CZ2.0-HEMI	2	E	16,0	16	32	100	48	15,2	0,1	-	2	■	
02881865	JS452200E2CZ2.0-HEMI	2	E	20,0	20	36	110	57	19,0	0,1	-	2	■	
02881853	JS452060E2R050Z2.0-HEMI	2	E	6,0	6	12	57	19	5,7	-	0,5	2	■	
02881854	JS452060E2R100Z2.0-HEMI	2	E	6,0	6	12	57	19	5,7	-	1,0	2	■	
02881855	JS452080E2R050Z2.0-HEMI	2	E	8,0	8	16	63	24	7,6	-	0,5	2	■	
02881779	JS452080E2R100Z2.0-HEMI	2	E	8,0	8	16	63	24	7,6	-	1,0	2	■	
02881857	JS452100E2R050Z2.0-HEMI	2	E	10,0	10	20	72	29	9,5	-	0,5	2	■	
02881858	JS452100E2R100Z2.0-HEMI	2	E	10,0	10	20	72	29	9,5	-	1,0	2	■	
02881860	JS452120E2R050Z2.0-HEMI	2	E	12,0	12	24	88	37	11,4	-	0,5	2	■	
02881861	JS452120E2R100Z2.0-HEMI	2	E	12,0	12	24	88	37	11,4	-	1,0	2	■	
02881780	JS452120E2R200Z2.0-HEMI	2	E	12,0	12	24	88	37	11,4	-	2,0	2	■	
02881864	JS452160E2R050Z2.0-HEMI	2	E	16,0	16	32	100	48	15,2	-	0,5	2	■	
02881782	JS452160E2R100Z2.0-HEMI	2	E	16,0	16	32	100	48	15,2	-	1,0	2	■	
02881783	JS452160E2R200Z2.0-HEMI	2	E	16,0	16	32	100	48	15,2	-	2,0	2	■	
02881784	JS452160E2R250Z2.0-HEMI	2	E	16,0	16	32	100	48	15,2	-	2,5	2	■	
02881785	JS452160E2R400Z2.0-HEMI	2	E	16,0	16	32	100	48	15,2	-	4,0	2	■	
02881866	JS452200E2R050Z2.0-HEMI	2	E	20,0	20	36	110	57	19,0	-	0,5	2	■	
02881768	JS452200E2R100Z2.0-HEMI	2	E	20,0	20	36	110	57	19,0	-	1,0	2	■	
02881775	JS452200E2R200Z2.0-HEMI	2	E	20,0	20	36	110	57	19,0	-	2,0	2	■	
02881819	JS452200E2R400Z2.0-HEMI	2	E	20,0	20	36	110	57	19,0	-	4,0	2	■	

■ Stock standard. Subject to change refer to current price- and stock-list

JS452 – High performance – Aluminium – Square – 2 Flutes – Weldon – Corner radius or chamfer



Tolerances:
 DMM= h5
 DC= e7
 RE= ±0,02
 CHW= +0,04 mm
 Regrind possible if DC is ≥Ø6

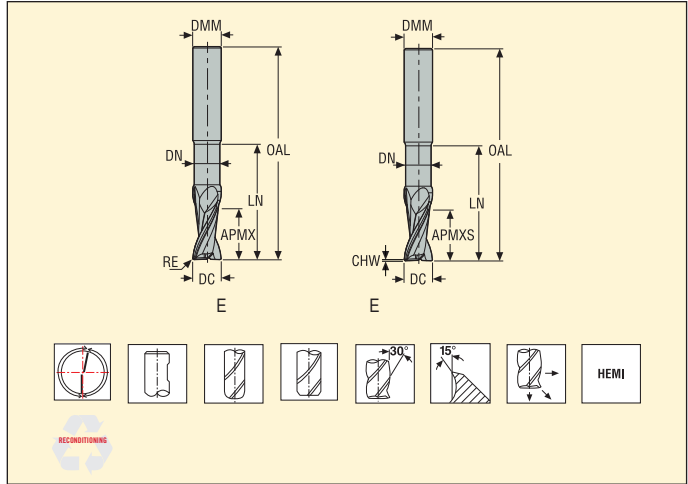

Ordering and Product No.	Designation	Length index	Tool shape	Dimensions in mm							RE	PCEDC	Weldon
				DC	DMM	APMXS	OAL	LN	DN	CHW			
02881867	JS452060E2CZ2.3-HEMI	2	E	6,0	6	12	57	19	5,7	0,1	-	2	<input type="checkbox"/>
02881947	JS452080E2CZ2.3-HEMI	2	E	8,0	8	16	63	24	7,6	0,1	-	2	<input type="checkbox"/>
02881871	JS452100E2CZ2.3-HEMI	2	E	10,0	10	20	72	29	9,5	0,1	-	2	<input type="checkbox"/>
02881874	JS452120E2CZ2.3-HEMI	2	E	12,0	12	24	88	37	11,4	0,1	-	2	<input type="checkbox"/>
02881877	JS452140E2CZ2.3-HEMI	2	E	14,0	14	28	88	41	13,3	0,1	-	2	<input type="checkbox"/>
02881878	JS452160E2CZ2.3-HEMI	2	E	16,0	16	32	100	48	15,2	0,1	-	2	<input type="checkbox"/>
02881880	JS452200E2CZ2.3-HEMI	2	E	20,0	20	36	110	57	19,0	0,1	-	2	<input type="checkbox"/>
02881868	JS452060E2R050Z2.3-HEMI	2	E	6,0	6	12	57	19	5,7	-	0,5	2	<input type="checkbox"/>
02881869	JS452060E2R100Z2.3-HEMI	2	E	6,0	6	12	57	19	5,7	-	1,0	2	<input type="checkbox"/>
02881870	JS452080E2R050Z2.3-HEMI	2	E	8,0	8	16	63	24	7,6	-	0,5	2	<input type="checkbox"/>
02922247	JS452080E2R100Z2.3-HEMI	2	E	8,0	8	16	63	24	7,6	-	1,0	2	<input type="checkbox"/>
02881872	JS452100E2R050Z2.3-HEMI	2	E	10,0	10	20	72	29	9,5	-	0,5	2	<input type="checkbox"/>
02881873	JS452100E2R100Z2.3-HEMI	2	E	10,0	10	20	72	29	9,5	-	1,0	2	<input type="checkbox"/>
02881875	JS452120E2R050Z2.3-HEMI	2	E	12,0	12	24	88	37	11,4	-	0,5	2	<input type="checkbox"/>
02881876	JS452120E2R100Z2.3-HEMI	2	E	12,0	12	24	88	37	11,4	-	1,0	2	<input type="checkbox"/>
02881948	JS452120E2R200Z2.3-HEMI	2	E	12,0	12	24	88	37	11,4	-	2,0	2	<input type="checkbox"/>
02881879	JS452160E2R050Z2.3-HEMI	2	E	16,0	16	32	100	48	15,2	-	0,5	2	<input type="checkbox"/>
02881949	JS452160E2R100Z2.3-HEMI	2	E	16,0	16	32	100	48	15,2	-	1,0	2	<input type="checkbox"/>
02881950	JS452160E2R200Z2.3-HEMI	2	E	16,0	16	32	100	48	15,2	-	2,0	2	<input type="checkbox"/>
02881951	JS452160E2R250Z2.3-HEMI	2	E	16,0	16	32	100	48	15,2	-	2,5	2	<input type="checkbox"/>
02881952	JS452160E2R400Z2.3-HEMI	2	E	16,0	16	32	100	48	15,2	-	4,0	2	<input type="checkbox"/>
02881881	JS452200E2R050Z2.3-HEMI	2	E	20,0	20	36	110	57	19,0	-	0,5	2	<input type="checkbox"/>
02881953	JS452200E2R100Z2.3-HEMI	2	E	20,0	20	36	110	57	19,0	-	1,0	2	<input type="checkbox"/>
02881959	JS452200E2R200Z2.3-HEMI	2	E	20,0	20	36	110	57	19,0	-	2,0	2	<input type="checkbox"/>
02881891	JS452200E2R400Z2.3-HEMI	2	E	20,0	20	36	110	57	19,0	-	4,0	2	<input type="checkbox"/>

Weldon available, delivery time is 3 days.

JS452 – High performance – Aluminium – Square – 2 Flutes – Cylindrical – Corner radius or chamfer



Tolerances:
 DMM= h5
 DC= e8
 RE= ±0,02 mm
 Regrind possible if DC is ≥Ø6

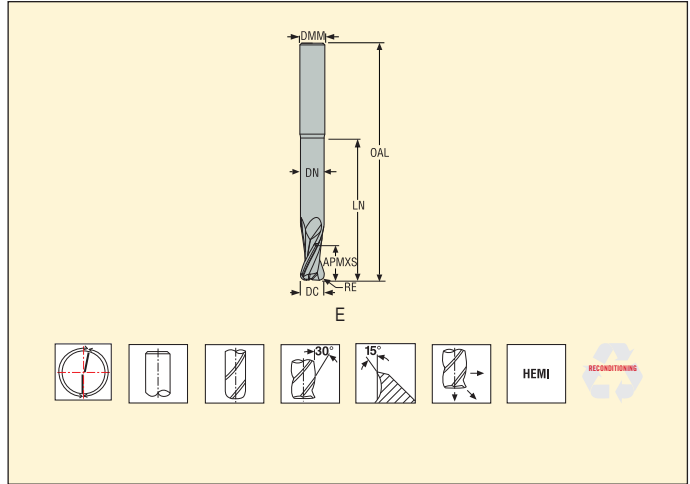

Ordering and Product No.	Designation	Length index	Tool shape	Dimensions in mm						RE	PCEDC	Cylindrical
				DC	DMM	APMXS	OAL	LN	DN			
03003413	JS452080E3R020.0Z2-HEMI	3	E	8,0	8	12	79	41	7,6	0,2	2	■
03003414	JS452080E3R050.0Z2-HEMI	3	E	8,0	8	12	79	41	7,6	0,5	2	■
03003415	JS452100E3R050.0Z2-HEMI	3	E	10,0	10	15	99	57	9,5	0,5	2	■
03003416	JS452100E3R100.0Z2-HEMI	3	E	10,0	10	15	99	57	9,5	1,0	2	■
03003417	JS452100E3R250.0Z2-HEMI	3	E	10,0	10	15	99	57	9,5	2,5	2	■
03003418	JS452100E3R300.0Z2-HEMI	3	E	10,0	10	15	99	57	9,5	3,0	2	■
03003419	JS452120E3R050.0Z2-HEMI	3	E	12,0	12	18	119	72	11,4	0,5	2	■
03003420	JS452120E3R100.0Z2-HEMI	3	E	12,0	12	18	119	72	11,4	1,0	2	■
03003421	JS452120E3R150.0Z2-HEMI	3	E	12,0	12	18	119	72	11,4	1,5	2	■
03003422	JS452120E3R200.0Z2-HEMI	3	E	12,0	12	18	119	72	11,4	2,0	2	■
03003423	JS452120E3R250.0Z2-HEMI	3	E	12,0	12	18	119	72	11,4	2,5	2	■
03003424	JS452120E3R300.0Z2-HEMI	3	E	12,0	12	18	119	72	11,4	3,0	2	■
03003425	JS452120E3R400.0Z2-HEMI	3	E	12,0	12	18	119	72	11,4	4,0	2	■
03003426	JS452160E3R050.0Z2-HEMI	3	E	16,0	16	24	129	79	15,2	0,5	2	■
03003427	JS452160E3R100.0Z2-HEMI	3	E	16,0	16	24	129	79	15,2	1,0	2	■
03003428	JS452160E3R200.0Z2-HEMI	3	E	16,0	16	24	129	79	15,2	2,0	2	■
03003429	JS452160E3R250.0Z2-HEMI	3	E	16,0	16	24	129	79	15,2	2,5	2	■
03003430	JS452160E3R300.0Z2-HEMI	3	E	16,0	16	24	129	79	15,2	3,0	2	■
03003431	JS452160E3R400.0Z2-HEMI	3	E	16,0	16	24	129	79	15,2	4,0	2	■
03003432	JS452160E3R600.0Z2-HEMI	3	E	16,0	16	24	129	79	15,2	6,0	2	■
03003433	JS452200E3R050.0Z2-HEMI	3	E	20,0	20	30	164	111	19,0	0,5	2	■
03003434	JS452200E3R200.0Z2-HEMI	3	E	20,0	20	30	164	111	19,0	2,0	2	■
03003435	JS452200E3R250.0Z2-HEMI	3	E	20,0	20	30	164	111	19,0	2,5	2	■
03003436	JS452200E3R300.0Z2-HEMI	3	E	20,0	20	30	164	111	19,0	3,0	2	■
03003437	JS452200E3R400.0Z2-HEMI	3	E	20,0	20	30	164	111	19,0	4,0	2	■
03003438	JS452200E3R500.0Z2-HEMI	3	E	20,0	20	30	164	111	19,0	5,0	2	■
03003439	JS452200E3R600.0Z2-HEMI	3	E	20,0	20	30	164	111	19,0	6,0	2	■

■ Stock standard. Subject to change refer to current price- and stock-list

JS452 – High performance – Aluminium – Square – 2 Flutes – Weldon – Corner radius or chamfer



Tolerances:
 DMM= h5
 DC= e7
 RE= ±0,02 mm
 Regrind possible if DC is ≥Ø6

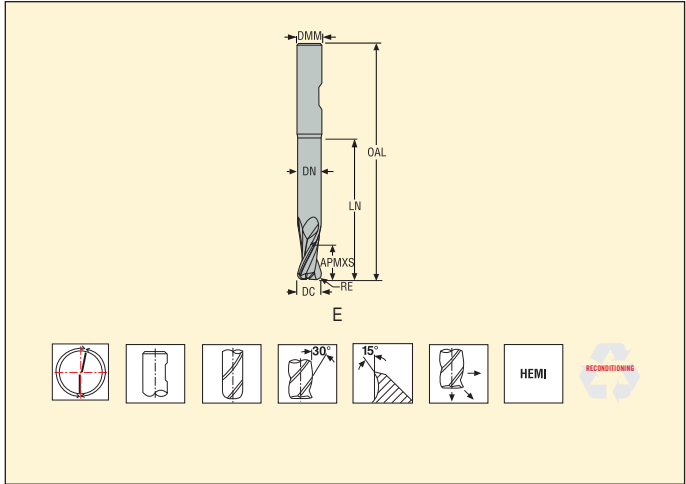

Ordering and Product No.	Designation	Length index	Tool shape	Dimensions in mm						RE	PCEDC	Weldon
				DC	DMM	APMXS	OAL	LN	DN			
03003447	JS452080E3R020.3Z2-HEMI	3	E	8,0	8	12	79	41	7,6	0,2	2	<input type="checkbox"/>
03003448	JS452080E3R050.3Z2-HEMI	3	E	8,0	8	12	79	41	7,6	0,5	2	<input type="checkbox"/>
03003449	JS452100E3R050.3Z2-HEMI	3	E	10,0	10	15	99	57	9,5	0,5	2	<input type="checkbox"/>
03003450	JS452100E3R100.3Z2-HEMI	3	E	10,0	10	15	99	57	9,5	1,0	2	<input type="checkbox"/>
03003451	JS452100E3R250.3Z2-HEMI	3	E	10,0	10	15	99	57	9,5	2,5	2	<input type="checkbox"/>
03003452	JS452100E3R300.3Z2-HEMI	3	E	10,0	10	15	99	57	9,5	3,0	2	<input type="checkbox"/>
03003453	JS452120E3R050.3Z2-HEMI	3	E	12,0	12	18	119	72	11,4	0,5	2	<input type="checkbox"/>
03003454	JS452120E3R100.3Z2-HEMI	3	E	12,0	12	18	119	72	11,4	1,0	2	<input type="checkbox"/>
03003455	JS452120E3R150.3Z2-HEMI	3	E	12,0	12	18	119	72	11,4	1,5	2	<input type="checkbox"/>
03003456	JS452120E3R200.3Z2-HEMI	3	E	12,0	12	18	119	72	11,4	2,0	2	<input type="checkbox"/>
03003457	JS452120E3R250.3Z2-HEMI	3	E	12,0	12	18	119	72	11,4	2,5	2	<input type="checkbox"/>
03003458	JS452120E3R300.3Z2-HEMI	3	E	12,0	12	18	119	72	11,4	3,0	2	<input type="checkbox"/>
03003459	JS452120E3R400.3Z2-HEMI	3	E	12,0	12	18	119	72	11,4	4,0	2	<input type="checkbox"/>
03003460	JS452160E3R050.3Z2-HEMI	3	E	16,0	16	24	129	79	15,2	0,5	2	<input type="checkbox"/>
03003461	JS452160E3R100.3Z2-HEMI	3	E	16,0	16	24	129	79	15,2	1,0	2	<input type="checkbox"/>
03003462	JS452160E3R200.3Z2-HEMI	3	E	16,0	16	24	129	79	15,2	2,0	2	<input type="checkbox"/>
03003463	JS452160E3R250.3Z2-HEMI	3	E	16,0	16	24	129	79	15,2	2,5	2	<input type="checkbox"/>
03003464	JS452160E3R300.3Z2-HEMI	3	E	16,0	16	24	129	79	15,2	3,0	2	<input type="checkbox"/>
03003465	JS452160E3R400.3Z2-HEMI	3	E	16,0	16	24	129	79	15,2	4,0	2	<input type="checkbox"/>
03003466	JS452160E3R600.3Z2-HEMI	3	E	16,0	16	24	129	79	15,2	6,0	2	<input type="checkbox"/>
03003467	JS452200E3R050.3Z2-HEMI	3	E	20,0	20	30	164	111	19,0	0,5	2	<input type="checkbox"/>
03003469	JS452200E3R200.3Z2-HEMI	3	E	20,0	20	30	164	111	19,0	2,0	2	<input type="checkbox"/>
03003470	JS452200E3R250.3Z2-HEMI	3	E	20,0	20	30	164	111	19,0	2,5	2	<input type="checkbox"/>
03003471	JS452200E3R300.3Z2-HEMI	3	E	20,0	20	30	164	111	19,0	3,0	2	<input type="checkbox"/>
03003472	JS452200E3R400.3Z2-HEMI	3	E	20,0	20	30	164	111	19,0	4,0	2	<input type="checkbox"/>
03003473	JS452200E3R500.3Z2-HEMI	3	E	20,0	20	30	164	111	19,0	5,0	2	<input type="checkbox"/>
03003474	JS452200E3R600.3Z2-HEMI	3	E	20,0	20	30	164	111	19,0	6,0	2	<input type="checkbox"/>

Weldon available, delivery time is 3 days.

Cutting data – JS452 Slot milling*

SMG		a_p/DC	f_z												v_c
			2	3	4	5	6	8	10	12	14	16	20		
N1	E	1,5	0,020	0,030	0,040	0,050	0,060	0,080	0,10	0,12	0,14	0,16	0,20	495 (395 – 590)	
N2	E	1,2	0,016	0,024	0,032	0,040	0,048	0,065	0,080	0,095	0,11	0,13	0,16	395 (295 – 495)	
N3	E	1,2	0,016	0,024	0,032	0,040	0,048	0,065	0,080	0,095	0,11	0,13	0,16	265 (195 – 330)	
TS1	A	1,5	0,020	0,030	0,040	0,050	0,060	0,080	0,10	0,12	0,14	0,16	0,20	495 (395 – 590)	
TP1	A	1,5	0,020	0,030	0,040	0,050	0,060	0,080	0,10	0,12	0,14	0,16	0,20	395 (295 – 495)	

Cutting data – JS452 Side milling roughing

SMG		a_e/DC	a_p/DC	f_z												v_c
				2	3	4	5	6	8	10	12	14	16	20		
N1	E/M/A	0,40	1,5	0,030	0,044	0,060	0,075	0,090	0,12	0,15	0,18	0,20	0,22	0,26	560 (445 – 670)	
N2	E/M/A	0,30	1,5	0,024	0,036	0,048	0,060	0,070	0,095	0,12	0,14	0,16	0,18	0,20	480 (360 – 600)	
N3	E/M/A	0,30	1,5	0,024	0,036	0,048	0,060	0,070	0,095	0,12	0,14	0,16	0,18	0,20	320 (240 – 400)	
TS1	A/D	0,40	1,5	0,030	0,044	0,060	0,075	0,090	0,12	0,15	0,18	0,20	0,22	0,26	560 (445 – 670)	
TP1	A/D	0,40	1,5	0,030	0,044	0,060	0,075	0,090	0,12	0,15	0,18	0,20	0,22	0,26	445 (335 – 560)	

Remark: if corner radius is >15% of DC then $a_p = -30\%$, $f_z = -20\%$

For cutting data recalculations, see page 411-418.

SMG = Seco material group

Coolant = A=air D=dry E=emulsion M=mist spray

$v_c = m/min$

$f_z = mm$

$a_p (mm)/DC (mm) = \text{factor}$

$a_e (mm)/DC (mm) = \text{factor}$

All cutting data are target values

JS453 – High performance – Aluminium – Square – 3 Flutes – Cylindrical – Corner radius or chamfer



Tolerances:
 DMM=h5
 DC=e7
 RE= ±0,02 mm
 CHW= +0,04 mm
 Regrind possible if DC is ≥Ø6

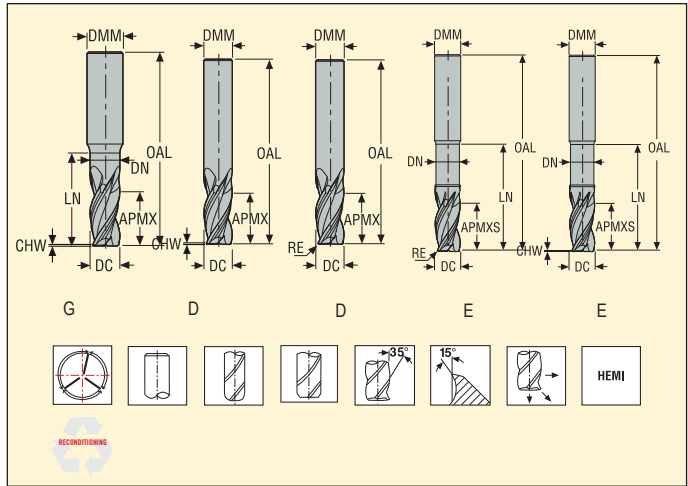

Ordering and Product No.	Designation	Length index	Tool shape	Dimensions in mm										PCEDC	Cylindrical
				DC	DMM	APMXS	OAL	LN	DN	CHW	RE				
02881896	JS453020G2CZ3.0-HEMI	2	G	2,0	6	4	57	7	1,9	0,1	-	3	■		
02881897	JS453030G2CZ3.0-HEMI	2	G	3,0	6	6	57	10	2,85	0,1	-	3	■		
02881898	JS453040G2CZ3.0-HEMI	2	G	4,0	6	8	57	13	3,8	0,1	-	3	■		
02881899	JS453050G2CZ3.0-HEMI	2	G	5,0	6	10	57	14	4,75	0,1	-	3	■		
02881900	JS453060D2CZ3.0-HEMI	2	D	6,0	6	12	57	-	-	0,1	-	3	■		
02881812	JS453080D2CZ3.0-HEMI	2	D	8,0	8	16	63	-	-	0,1	-	3	■		
02881903	JS453100D2CZ3.0-HEMI	2	D	10,0	10	20	72	-	-	0,1	-	3	■		
02881905	JS453120D2CZ3.0-HEMI	2	D	12,0	12	24	88	-	-	0,1	-	3	■		
02881907	JS453140D2CZ3.0-HEMI	2	D	14,0	14	28	88	-	-	0,1	-	3	■		
02881908	JS453160D2CZ3.0-HEMI	2	D	16,0	16	32	100	-	-	0,1	-	3	■		
02905286	JS453200E2C.0Z3-HEMI	2	E	20,0	20	36	110	57	19,0	0,1	-	3	■		
02881901	JS453060D2R050Z3.0-HEMI	2	D	6,0	6	12	57	-	-	-	0,5	3	■		
02881902	JS453080D2R050Z3.0-HEMI	2	D	8,0	8	16	63	-	-	-	0,5	3	■		
02881904	JS453100D2R050Z3.0-HEMI	2	D	10,0	10	20	72	-	-	-	0,5	3	■		
02881906	JS453120D2R050Z3.0-HEMI	2	D	12,0	12	24	88	-	-	-	0,5	3	■		
02905280	JS453120E2R300.0Z3-HEMI	2	E	12,0	12	24	88	37	11,4	-	3,0	3	■		
02881909	JS453160D2R050Z3.0-HEMI	2	D	16,0	16	32	100	-	-	-	0,5	3	■		
02905281	JS453160E2R100.0Z3-HEMI	2	E	16,0	16	32	100	48	15,2	-	1,0	3	■		
02905282	JS453160E2R200.0Z3-HEMI	2	E	16,0	16	32	100	48	15,2	-	2,0	3	■		
02905283	JS453160E2R250.0Z3-HEMI	2	E	16,0	16	32	100	48	15,2	-	2,5	3	■		
02905284	JS453160E2R300.0Z3-HEMI	2	E	16,0	16	32	100	48	15,2	-	3,0	3	■		
02905285	JS453160E2R400.0Z3-HEMI	2	E	16,0	16	32	100	48	15,2	-	4,0	3	■		
02905287	JS453200E2R050.0Z3-HEMI	2	E	20,0	20	36	110	57	19,0	-	0,5	3	■		
02905288	JS453200E2R100.0Z3-HEMI	2	E	20,0	20	36	110	57	19,0	-	1,0	3	■		
02905289	JS453200E2R200.0Z3-HEMI	2	E	20,0	20	36	110	57	19,0	-	2,0	3	■		
02905290	JS453200E2R250.0Z3-HEMI	2	E	20,0	20	36	110	57	19,0	-	2,5	3	■		
02905291	JS453200E2R300.0Z3-HEMI	2	E	20,0	20	36	110	57	19,0	-	3,0	3	■		
02905292	JS453200E2R400.0Z3-HEMI	2	E	20,0	20	36	110	57	19,0	-	4,0	3	■		
02905293	JS453200E2R600.0Z3-HEMI	2	E	20,0	20	36	110	57	19,0	-	6,0	3	■		

■ Stock standard. Subject to change refer to current price- and stock-list

JS453 – High performance – Aluminium – Square – 3 Flutes – Cylindrical – Corner radius or chamfer



Tolerances:
 DMM= h5
 DC = e7
 RE= ±0,02 mm
 CHW= +0,04 mm
 Regrind possible if DC is ≥Ø6

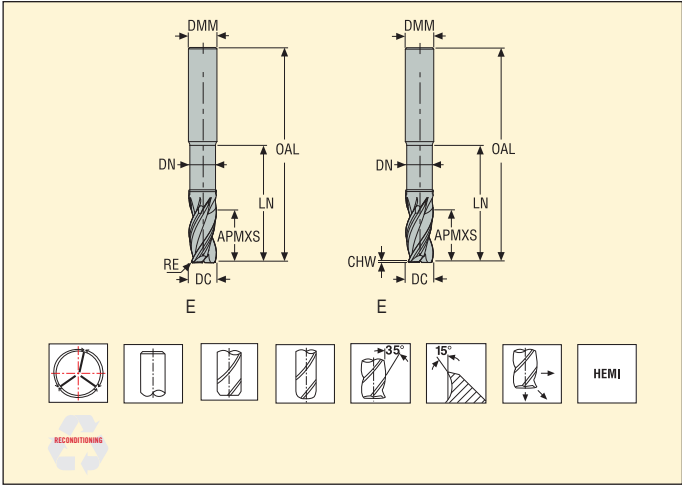

Ordering and Product No.	Designation	Length index	Tool shape	Dimensions in mm								RE	PCEDC	Cylindrical
				DC	DMM	OAL	LN	APMXS	DN	CHW				
02905294	JS453120E3R300.0Z3-HEMI	3	E	12,0	12	110	54	24	11,4	-	3,0	3	■	
02905295	JS453160E3R100.0Z3-HEMI	3	E	16,0	16	125	77	32	15,2	-	1,0	3	■	
02905296	JS453160E3R200.0Z3-HEMI	3	E	16,0	16	125	77	32	15,2	-	2,0	3	■	
02905297	JS453160E3R250.0Z3-HEMI	3	E	16,0	16	125	77	32	15,2	-	2,5	3	■	
02905298	JS453160E3R300.0Z3-HEMI	3	E	16,0	16	125	77	32	15,2	-	3,0	3	■	
02905299	JS453160E3R400.0Z3-HEMI	3	E	16,0	16	125	77	32	15,2	-	4,0	3	■	
02905300	JS453200E3C.0Z3-HEMI	3	E	20,0	20	150	90	36	19,0	0,1	-	3	■	
02905301	JS453200E3R050.0Z3-HEMI	3	E	20,0	20	150	90	36	19,0	-	0,5	3	■	
02905302	JS453200E3R100.0Z3-HEMI	3	E	20,0	20	150	90	36	19,0	-	1,0	3	■	
02905303	JS453200E3R200.0Z3-HEMI	3	E	20,0	20	150	90	36	19,0	-	2,0	3	■	
02905304	JS453200E3R250.0Z3-HEMI	3	E	20,0	20	150	90	36	19,0	-	2,5	3	■	
02905305	JS453200E3R300.0Z3-HEMI	3	E	20,0	20	150	90	36	19,0	-	3,0	3	■	
02905306	JS453200E3R400.0Z3-HEMI	3	E	20,0	20	150	90	36	19,0	-	4,0	3	■	

■ Stock standard. Subject to change refer to current price- and stock-list

JS453 – High performance – Aluminium – Square – 3 Flutes – Weldon – Corner radius or chamfer



Tolerances:
 DMM=h5
 DC=e7
 CHW= ±0,02 mm
 Regrind possible if DC is ≥ø6

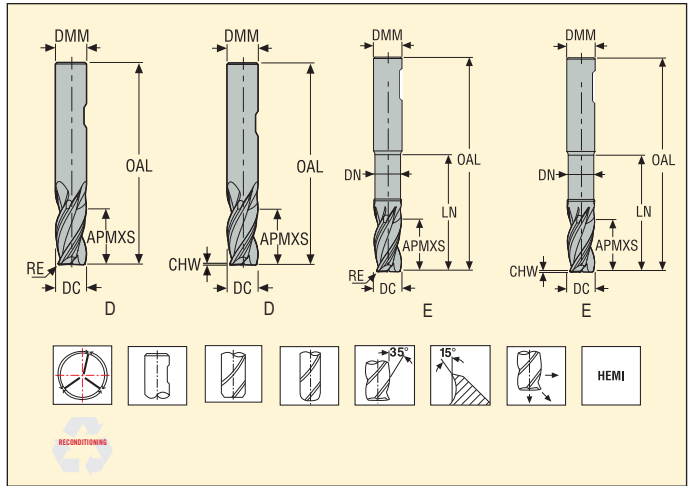

Ordering and Product No.	Designation	Length index	Tool shape	Dimensions in mm							RE	PCEDC	Weldon
				DC	DMM	APMXS	OAL	LN	DN	CHW			
02881910	JS453060D2CZ3.3-HEMI	2	D	6,0	6	12	57	-	-	0,1	-	3	<input type="checkbox"/>
02881964	JS453080D2CZ3.3-HEMI	2	D	8,0	8	16	63	-	-	0,1	-	3	<input type="checkbox"/>
02881913	JS453100D2CZ3.3-HEMI	2	D	10,0	10	20	72	-	-	0,1	-	3	<input type="checkbox"/>
02881915	JS453120D2CZ3.3-HEMI	2	D	12,0	12	24	88	-	-	0,1	-	3	<input type="checkbox"/>
02881917	JS453140D2CZ3.3-HEMI	2	D	14,0	14	28	88	-	-	0,1	-	3	<input type="checkbox"/>
02881918	JS453160D2CZ3.3-HEMI	2	D	16,0	16	32	100	-	-	0,1	-	3	<input type="checkbox"/>
02905314	JS453200E2C.3Z3-HEMI	2	E	20,0	20	36	110	57	19,0	0,1	-	3	<input type="checkbox"/>
02881911	JS453060D2R050Z3.3-HEMI	2	D	6,0	6	12	57	-	-	-	0,5	3	<input type="checkbox"/>
02881954	JS453080D2R050Z3.3-HEMI	2	D	8,0	8	16	63	-	-	-	0,5	3	<input type="checkbox"/>
02881914	JS453100D2R050Z3.3-HEMI	2	D	10,0	10	20	72	-	-	-	0,5	3	<input type="checkbox"/>
02881916	JS453120D2R050Z3.3-HEMI	2	D	12,0	12	24	88	-	-	-	0,5	3	<input type="checkbox"/>
02905308	JS453120E2R300.3Z3-HEMI	2	E	12,0	12	24	88	37	11,4	-	3,0	3	<input type="checkbox"/>
02881919	JS453160D2R050Z3.3-HEMI	2	D	16,0	16	32	100	-	-	-	0,5	3	<input type="checkbox"/>
02905309	JS453160E2R100.3Z3-HEMI	2	E	16,0	16	32	100	48	15,2	-	1,0	3	<input type="checkbox"/>
02905310	JS453160E2R200.3Z3-HEMI	2	E	16,0	16	32	100	48	15,2	-	2,0	3	<input type="checkbox"/>
02905311	JS453160E2R250.3Z3-HEMI	2	E	16,0	16	32	100	48	15,2	-	2,5	3	<input type="checkbox"/>
02905312	JS453160E2R300.3Z3-HEMI	2	E	16,0	16	32	100	48	15,2	-	3,0	3	<input type="checkbox"/>
02905313	JS453160E2R400.3Z3-HEMI	2	E	16,0	16	32	100	48	15,2	-	4,0	3	<input type="checkbox"/>
02905315	JS453200E2R050.3Z3-HEMI	2	E	20,0	20	36	110	57	19,0	-	0,5	3	<input type="checkbox"/>
02905316	JS453200E2R100.3Z3-HEMI	2	E	20,0	20	36	110	57	19,0	-	1,0	3	<input type="checkbox"/>
02905317	JS453200E2R200.3Z3-HEMI	2	E	20,0	20	36	110	57	19,0	-	2,0	3	<input type="checkbox"/>
02905318	JS453200E2R250.3Z3-HEMI	2	E	20,0	20	36	110	57	19,0	-	2,5	3	<input type="checkbox"/>
02905319	JS453200E2R300.3Z3-HEMI	2	E	20,0	20	36	110	57	19,0	-	3,0	3	<input type="checkbox"/>
02905320	JS453200E2R400.3Z3-HEMI	2	E	20,0	20	36	110	57	19,0	-	4,0	3	<input type="checkbox"/>
02905321	JS453200E2R600.3Z3-HEMI	2	E	20,0	20	36	110	57	19,0	-	6,0	3	<input type="checkbox"/>

Weldon available, delivery time is 3 days.

JS453 – High performance – Aluminium – Square – 3 Flutes – Weldon – Corner radius or chamfer

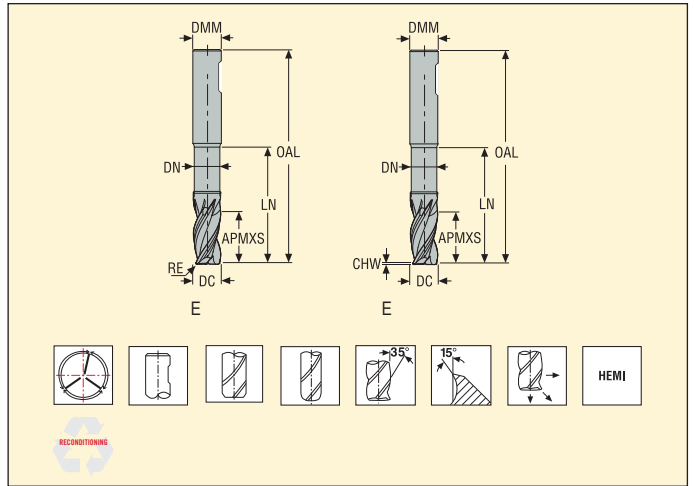

Tolerances:

DMM= h5

DC = e7

RE= ±0,02 mm

CHW= +0,04 mm

Regrind possible if DC is ≥Ø6

Ordering and Product No.	Designation	Length index	Tool shape	Dimensions in mm								RE	PCEDC	Weldon
				DC	DMM	OAL	LN	APMXS	DN	CHW				
02905328	JS453200E3C.3Z3-HEMI	3	E	20,0	20	150	90	36	19,0	0,1	-	3	<input type="checkbox"/>	
02905322	JS453120E3R300.3Z3-HEMI	3	E	12,0	12	110	54	24	11,4	-	3,0	3	<input type="checkbox"/>	
02905323	JS453160E3R100.3Z3-HEMI	3	E	16,0	16	125	77	32	15,2	-	1,0	3	<input type="checkbox"/>	
02905324	JS453160E3R200.3Z3-HEMI	3	E	16,0	16	125	77	32	15,2	-	2,0	3	<input type="checkbox"/>	
02905325	JS453160E3R250.3Z3-HEMI	3	E	16,0	16	125	77	32	15,2	-	2,5	3	<input type="checkbox"/>	
02905326	JS453160E3R300.3Z3-HEMI	3	E	16,0	16	125	77	32	15,2	-	3,0	3	<input type="checkbox"/>	
02905327	JS453160E3R400.3Z3-HEMI	3	E	16,0	16	125	77	32	15,2	-	4,0	3	<input type="checkbox"/>	
02905329	JS453200E3R050.3Z3-HEMI	3	E	20,0	20	150	90	36	19,0	-	0,5	3	<input type="checkbox"/>	
02905330	JS453200E3R100.3Z3-HEMI	3	E	20,0	20	150	90	36	19,0	-	1,0	3	<input type="checkbox"/>	
02905331	JS453200E3R200.3Z3-HEMI	3	E	20,0	20	150	90	36	19,0	-	2,0	3	<input type="checkbox"/>	
02905332	JS453200E3R250.3Z3-HEMI	3	E	20,0	20	150	90	36	19,0	-	2,5	3	<input type="checkbox"/>	
02905333	JS453200E3R300.3Z3-HEMI	3	E	20,0	20	150	90	36	19,0	-	3,0	3	<input type="checkbox"/>	
02905334	JS453200E3R400.3Z3-HEMI	3	E	20,0	20	150	90	36	19,0	-	4,0	3	<input type="checkbox"/>	

Weldon available, delivery time is 3 days.

Cutting data – JS453 Slot milling

SMG		a _p /DC	f _z											v _c
			2	3	4	5	6	8	10	12	14	16	20	
N1	E	1,5	0,020	0,030	0,040	0,050	0,060	0,080	0,10	0,12	0,14	0,16	0,20	500 (400 – 600)
N2	E	1,2	0,016	0,024	0,032	0,040	0,048	0,065	0,080	0,095	0,11	0,13	0,16	400 (300 – 500)
N3	E	1,2	0,016	0,024	0,032	0,040	0,048	0,065	0,080	0,095	0,11	0,13	0,16	265 (200 – 335)
TS1	A	1,5	0,020	0,030	0,040	0,050	0,060	0,080	0,10	0,12	0,14	0,16	0,20	500 (400 – 600)
TP1	A	1,5	0,020	0,030	0,040	0,050	0,060	0,080	0,10	0,12	0,14	0,16	0,20	400 (300 – 500)

Cutting data – JS453 Side milling

SMG		a _e /DC	a _p /DC	f _z											v _c
				2	3	4	5	6	8	10	12	14	16	20	
N1	E/M/A	0,40	1,5	0,030	0,046	0,060	0,075	0,090	0,12	0,15	0,18	0,20	0,22	0,26	560 (445 – 670)
N2	E/M/A	0,30	1,5	0,024	0,036	0,048	0,060	0,070	0,095	0,12	0,14	0,16	0,18	0,20	480 (360 – 600)
N3	E/M/A	0,30	1,5	0,024	0,036	0,048	0,060	0,070	0,095	0,12	0,14	0,16	0,18	0,20	320 (240 – 400)
TS1	A/D	0,40	1,5	0,030	0,046	0,060	0,075	0,090	0,12	0,15	0,18	0,20	0,22	0,26	560 (445 – 670)
TP1	A/D	0,40	1,5	0,030	0,046	0,060	0,075	0,090	0,12	0,15	0,18	0,20	0,22	0,26	445 (335 – 560)

For cutting data recalculations, see page 411-418.

SMG = Seco material group

Coolant = A=air D=dry E=emulsion M=mist spray

v_c = m/min

f_z = mm

a_p (mm)/DC (mm)= factor

a_e (mm)/DC (mm)= factor

All cutting data are target values

JHP490 – High performance – Aluminium – Square – 2-3 Flutes – Cylindrical – Corner radius – ICC



Tolerances:
 DMM=h5
 DC= -0,02/-0,1 mm
 RE= ±0,05 mm
 Regrind possible if DC is ≥Ø6

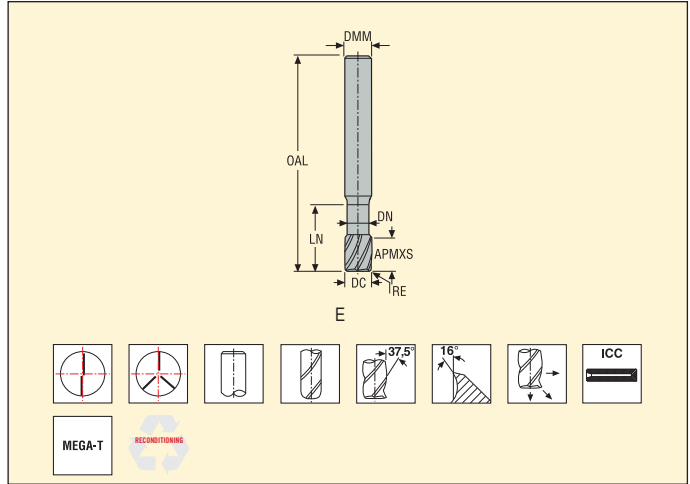

Ordering and Product No.	Designation	Length index	Tool shape	ICC	Dimensions in mm						RE	PCEDC	Cylindrical
					DC	DMM	APMXS	OAL	LN	DN			
02623870	490V100R050Z2.0A-MEGA-T	2	E	■	10,0	10	12	65	20	9,0	0,5	2	■
02623873	490V100R200Z2.0A-MEGA-T	2	E	■	10,0	10	12	65	20	9,0	2,0	2	■
02623883	490V120R200Z2.0A-MEGA-T	2	E	■	12,0	12	14	75	24	11,0	2,0	2	■
02623889	490V160R050Z3.0A-MEGA-T	2	E	■	16,0	16	18	85	32	14,5	0,5	3	■
02623895	490V160R200Z3.0A-MEGA-T	2	E	■	16,0	16	18	85	32	14,5	2,0	3	■
02623908	490V200R050Z3.0A-MEGA-T	2	E	■	20,0	20	22	100	40	18,0	0,5	3	■
02623926	490V250R050Z3.0A-MEGA-T	2	E	■	25,0	25	27	125	50	23,0	0,5	3	■
02623876	490VL100R100Z2.0A-MEGA-T	3	E	■	10,0	10	22	85	42	9,0	1,0	2	■
02623880	490VL120R050Z3.0A-MEGA-T	3	E	■	12,0	12	14	95	40	11,0	0,5	3	■
02623886	490VL120R100Z2.0A-MEGA-T	3	E	■	12,0	12	26	95	50	11,0	1,0	2	■
02623891	490VL160R050Z3.0A-MEGA-T	3	E	■	16,0	16	18	95	45	14,5	0,5	3	■
02623916	490VL200R200Z3.0A-MEGA-T	3	E	■	20,0	20	42	125	65	18,0	2,0	3	■
02623927	490VXL250R050Z3.0A-MEGA-T	4	E	■	25,0	25	50	125	75	23,0	0,5	3	■

ICC = Internal Coolant Channel

■ Stock standard. Subject to change refer to current price- and stock-list

JHP490 - High performance - Aluminium - Square - 2-3 Flutes - Weldon - Corner radius - ICC



Tolerances:
 DMM=h5
 DC= -0,02/-0,1 mm
 RE= ±0,05 mm
 Regrind possible if DC is ≥Ø6

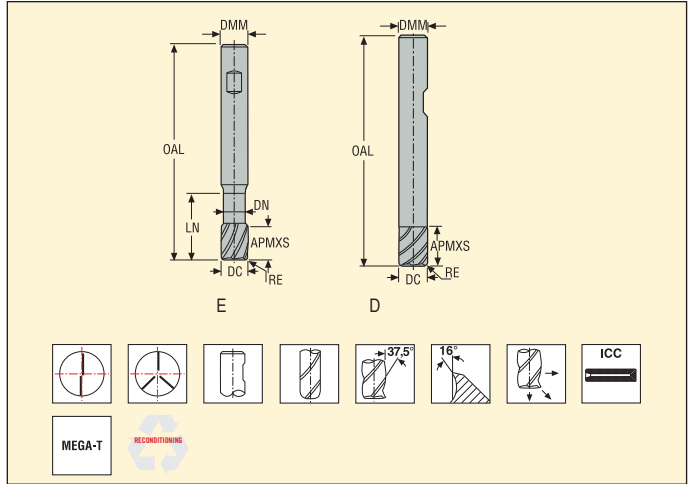

Ordering and Product No.	Designation	Length index	Tool shape	ICC	Dimensions in mm							PCEDC	Weldon
					DC	DMM	APMXS	OAL	LN	DN	RE		
02623875	490100R100Z2A-MEGA-T	2	D	■	10,0	10	22	75	-	-	1,0	2	■
02623885	490120R100Z2A-MEGA-T	2	D	■	12,0	12	26	85	-	-	1,0	2	■
02623898	490160R200Z3A-MEGA-T	2	D	■	16,0	16	34	95	-	-	2,0	3	■
02669366	490V100R200Z2.0A-MEGA-TW	2	E	■	10,0	10	12	65	20	9,0	2,0	2	□
02623878	490V120R050Z2A-MEGA-T	2	E	■	12,0	12	14	75	24	11,0	0,5	2	■
02669371	490V120R200Z2.0A-MEGA-TW	2	E	■	12,0	12	14	75	24	11,0	2,0	2	□
02623888	490V160R050Z3A-MEGA-T	2	E	■	16,0	16	18	85	32	14,5	0,5	3	■
02623894	490V160R200Z3A-MEGA-T	2	E	■	16,0	16	18	85	32	14,5	2,0	3	■
02623907	490V200R050Z3A-MEGA-T	2	E	■	20,0	20	22	100	40	18,0	0,5	3	■
02623925	490V250R050Z3A-MEGA-T	2	E	■	25,0	25	27	125	50	23,0	0,5	3	■
02669368	490VL100R100Z2.0A-MEGA-TW	3	E	■	10,0	10	22	85	42	9,0	1,0	2	□
02669374	490VL120R050Z3.0A-MEGA-TW	3	E	■	12,0	12	14	95	40	11,0	0,5	3	□
02669375	490VL120R100Z2.0A-MEGA-TW	3	E	■	12,0	12	26	95	50	11,0	1,0	2	□
02669382	490VL160R050Z3.0A-MEGA-TW	3	E	■	16,0	16	18	95	45	14,5	0,5	3	□
02669388	490VL200R200Z3.0A-MEGA-TW	3	E	■	20,0	20	42	125	65	18,0	2,0	3	□
02669397	490VXL250R050Z3.0A-MEGA-TW	4	E	■	25,0	25	50	125	75	23,0	0,5	3	□

ICC = Internal Coolant Channel

■ Stock standard. Subject to change refer to current price- and stock-list □ Weldon available, delivery time is 3 days.

JHP490 – High performance – Aluminium – Square – 2-3 Flutes – Safelock – Corner radius – ICC



Tolerances:
 DMM=h5
 DC= -0,02/-0,1 mm
 RE= ±0,05 mm
 Regrind possible if DC is ≥Ø6

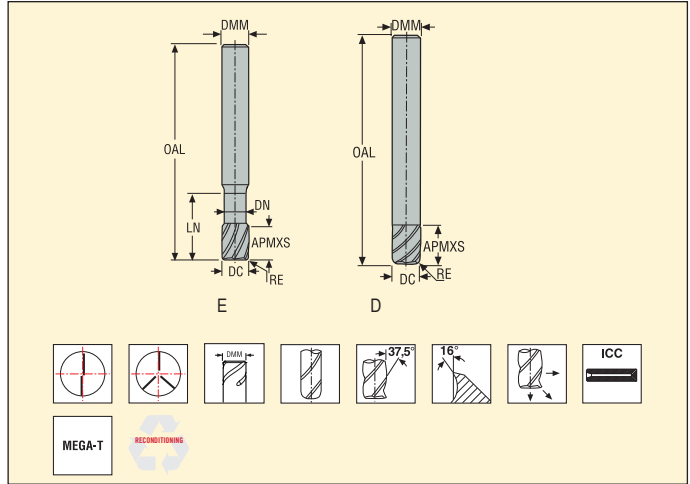

Ordering and Product No.	Designation	Length index	Tool shape	ICC	Dimensions in mm							PCEDC	Safelock
					DC	DMM	APMXS	OAL	LN	DN	RE		
02927983	490100R100Z2.9A-MEGA-T	2	D	■	10,0	10	22	75	-	-	1,0	2	<input type="checkbox"/>
02927987	490120R100Z2.9A-MEGA-T	2	D	■	12,0	12	26	85	-	-	1,0	2	<input type="checkbox"/>
02927989	490160R200Z3.9A-MEGA-T	2	E	■	16,0	16	18	85	32	14	2,0	3	<input type="checkbox"/>
02927984	490V100R050Z2.9A-MEGA-T	2	E	■	10,0	10	12	65	20	9	0,5	2	<input type="checkbox"/>
02927985	490V100R200Z2.9A-MEGA-T	2	E	■	10,0	10	12	65	20	9	2,0	2	<input type="checkbox"/>
02927986	490V120R050Z2.9A-MEGA-T	2	E	■	12,0	12	14	75	24	11	0,5	2	<input type="checkbox"/>
02927988	490V120R200Z2.9A-MEGA-T	2	E	■	12,0	12	14	75	24	11	2,0	2	<input type="checkbox"/>
02927990	490V160R050Z3.9A-MEGA-T	2	E	■	16,0	16	18	85	32	14	0,5	3	<input type="checkbox"/>
02927991	490V160R200Z3.9A-MEGA-T	2	E	■	16,0	16	18	85	32	14	2,0	3	<input type="checkbox"/>
02927992	490V200R050Z3.9A-MEGA-T	2	E	■	20,0	20	22	100	40	18	0,5	3	<input type="checkbox"/>
02927993	490V250R050Z3.9A-MEGA-T	2	E	■	25,0	25	27	125	50	23	0,5	3	<input type="checkbox"/>
02927994	490VL100R100Z2.9A-MEGA-T	3	E	■	10,0	10	22	85	42	9	1,0	2	<input type="checkbox"/>
02927995	490VL120R050Z3.9A-MEGA-T	3	E	■	12,0	12	14	95	40	11	0,5	3	<input type="checkbox"/>
02927996	490VL120R100Z2.9A-MEGA-T	3	E	■	12,0	12	26	95	50	11	1,0	2	<input type="checkbox"/>
02927997	490VL160R050Z3.9A-MEGA-T	3	E	■	16,0	16	18	95	32	14	0,5	3	<input type="checkbox"/>
02927998	490VL200R200Z3.9A-MEGA-T	3	E	■	20,0	20	42	125	65	18	2,0	3	<input type="checkbox"/>
02927999	490VXL250R050Z3.9A-MEGA-T	4	E	■	25,0	25	50	125	75	23	0,5	3	<input type="checkbox"/>

ICC = Internal Coolant Channel

Safelock available. Subject to change, refer to current Price and Stock List.

Cutting data – JHP490 Slot milling PCEDC 2

SMG		a_p/DC	f_z						v_c
			10	12	16	20	25		
N1	E/M/A	1,0	0,15	0,18	0,22	0,26	0,28	660 (510 — 810)	
N2	E/M/A	1,0	0,15	0,18	0,22	0,26	0,28	425 (325 — 520)	
N3	E/M/A	1,0	0,15	0,18	0,22	0,26	0,28	510 (405 — 610)	

Cutting data – JHP490 Side milling roughing

SMG		a_e/DC	a_p/DC	f_z						v_c
				10	12	16	20	25		
N1	E/M/A	0,50	1,1	0,15	0,18	0,22	0,26	0,28	780 (600 — 960)	
N2	E/M/A	0,50	1,1	0,15	0,18	0,22	0,26	0,28	500 (385 — 620)	
N3	E/M/A	0,50	1,1	0,15	0,18	0,22	0,26	0,28	600 (480 — 720)	

For cutting data recalculations, see page 411-418.

SMG = Seco material group

Coolant = A=air D=dry E=emulsion M=mist spray

v_c = m/min

f_z = mm

a_p (mm)/DC (mm)= factor

a_e (mm)/DC (mm)= factor

All cutting data are target values

Cutting data – JH40 Slot milling

SMG		a _p /DC	f _z											v _c
			2	3	4	5	6	8	10	12	16	20		
N1	E/M/A	0,60	0,026	0,040	0,050	0,065	0,080	0,10	0,13	0,16	0,20	0,24	600 (500 – 700)	
N11	E/M/A	0,40	0,016	0,024	0,032	0,040	0,048	0,065	0,080	0,095	0,13	0,16	400 (300 – 500)	
TS1	A	1,0	0,026	0,040	0,050	0,065	0,080	0,10	0,13	0,16	0,20	0,24	600 (500 – 700)	

Cutting data – JH40 Side milling

SMG		a _e /DC	a _p /DC	f _z											v _c
				2	3	4	5	6	8	10	12	16	20		
N1	E/M/A	0,40	1,1	0,030	0,046	0,060	0,075	0,090	0,12	0,15	0,18	0,22	0,26	730 (600 – 850)	
N11	E/M/A	0,40	1,0	0,030	0,046	0,060	0,075	0,090	0,12	0,15	0,18	0,22	0,26	425 (320 – 530)	
TS1	A	0,40	1,2	0,030	0,046	0,060	0,075	0,090	0,12	0,15	0,18	0,22	0,26	730 (610 – 850)	

For cutting data recalculations, see page 411-418.

SMG = Seco material group

Coolant = A=air D=dry E=emulsion M=mist spray

v_c = m/min

f_z = mm

a_p (mm)/DC (mm)= factor

a_e (mm)/DC (mm)= factor

All cutting data are target values

Cutting data – JH421 Slot milling

SMG		a _p /DC	f _z												v _c
			2	3	4	5	6	8	10	12	14	16	20	25	
N1	E/M/A	0,50	0,014	0,022	0,028	0,036	0,042	0,055	0,070	0,085	0,10	0,11	0,14	0,18	610 (510 – 710)
N11	E/M/A	0,50	0,0080	0,012	0,016	0,020	0,024	0,032	0,040	0,050	0,055	0,065	0,080	0,10	405 (305 – 510)
TS1	A	0,50	0,014	0,022	0,028	0,036	0,042	0,055	0,070	0,085	0,10	0,11	0,14	0,18	610 (510 – 710)
TP1	M	0,50	0,010	0,015	0,020	0,026	0,030	0,040	0,050	0,060	0,070	0,080	0,10	0,13	405 (305 – 510)

Cutting data – JH421 Side milling

SMG		a _e /DC	a _p /DC	f _z												v _c
				2	3	4	5	6	8	10	12	14	16	20	25	
N1	E/M/A	0,40	1,0	0,030	0,044	0,060	0,075	0,090	0,12	0,15	0,18	0,20	0,22	0,26	0,28	620 (510 – 720)
N11	E/M/A	0,40	1,0	0,020	0,030	0,040	0,050	0,060	0,080	0,10	0,12	0,13	0,15	0,17	0,19	410 (305 – 510)
TS1	A	0,40	1,0	0,030	0,044	0,060	0,075	0,090	0,12	0,15	0,18	0,20	0,22	0,26	0,28	620 (510 – 720)
TP1	M	0,40	1,0	0,024	0,036	0,048	0,060	0,070	0,095	0,12	0,14	0,16	0,18	0,20	0,24	410 (305 – 510)

For cutting data recalculations, see page 411-418.

SMG = Seco material group

Coolant = A=air D=dry E=emulsion M=mist spray

v_c = m/min

f_z = mm

a_p (mm)/DC (mm)= factor

a_e (mm)/DC (mm)= factor

All cutting data are target values

JH410 – High performance – Aluminium – Square – 1 Flute – Cylindrical – Corner radius

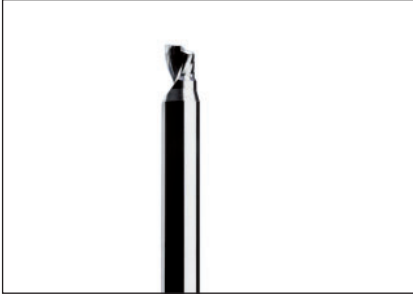

Tolerances:
 DMM= h5
 DC= ±0,05 mm
 RE= ±0,05 mm
 Regrind possible if DC is ≥Ø6

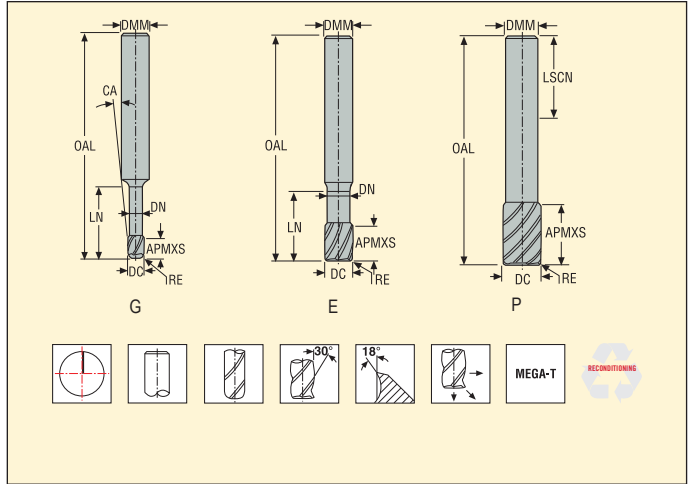

Ordering and Product No.	Designation	Length index	Tool shape	Dimensions in mm								RE	CA	PCEDC	Cylindrical
				DC	DMM	APMXS	OAL	LN	LSCN	DN	TRE				
02451548	410020R050-MEGA-T	2	G	2,0	6	3	50	6	36	1,7	0,5	12,0	1	■	
02451577	410ML020R050-MEGA-T	2	G	2,0	6	3	50	12	36	1,7	0,5	7,5	1	■	
02451578	410030R050-MEGA-T	2	G	3,0	6	4	50	8	36	2,7	0,5	7,5	1	■	
02451580	410ML030R050-MEGA-T	2	G	3,0	6	4	60	15	36	2,7	0,5	5,0	1	■	
02451581	410040R050-MEGA-T	2	G	4,0	6	5	60	8	36	3,6	0,5	5,5	1	■	
02451585	410ML040R050-MEGA-T	2	G	4,0	6	5	60	15	36	3,6	0,5	3,5	1	■	
02451586	410050R050-MEGA-T	2	G	5,0	6	7	65	11	36	4,5	0,5	2,5	1	■	
02451589	410ML050R050-MEGA-T	2	G	5,0	6	7	65	18	36	4,5	0,5	1,5	1	■	
02451591	410060R050-MEGA-T	2	E	6,0	6	8	70	11	36	5,3	0,5	-	1	■	
02451593	410ML060R050-MEGA-T	2	E	6,0	6	8	70	18	36	5,3	0,5	-	1	■	
02451594	410070RSR050-MEGA-T	2	P	7,0	6	9	65	-	36	-	0,5	-	1	■	
02451596	410090RSR050-MEGA-T	2	P	9,0	8	11	65	-	36	-	0,5	-	1	■	
02451598	410110RSR050-MEGA-T	2	P	11,0	10	13	70	-	40	-	0,5	-	1	■	
02451600	410130RSR100-MEGA-T	2	P	13,0	12	15	70	-	45	-	1,0	-	1	■	
02451603	410150RSR100-MEGA-T	2	P	15,0	14	17	80	-	45	-	1,0	-	1	■	
02451605	410170RSR100-MEGA-T	2	P	17,0	16	19	80	-	48	-	1,0	-	1	■	
02451595	410L070RSR200-MEGA-T	3	P	7,0	6	9	85	-	36	-	2,0	-	1	■	
02451597	410L090RSR200-MEGA-T	3	P	9,0	8	11	85	-	36	-	2,0	-	1	■	
02451599	410L110RSR200-MEGA-T	3	P	11,0	10	13	90	-	40	-	2,0	-	1	■	
02451601	410L130RSR200-MEGA-T	3	P	13,0	12	15	90	-	45	-	2,0	-	1	■	
02451604	410L150RSR200-MEGA-T	3	P	15,0	14	17	110	-	45	-	2,0	-	1	■	
02451606	410L170RSR200-MEGA-T	3	P	17,0	16	19	110	-	48	-	2,0	-	1	■	
02451579	410TL030R050-MEGA-T	2	G	3,0	6	4	60	21	36	2,7	0,5	4,0	1	■	
02451582	410TL040R050-MEGA-T	2	G	4,0	6	5	60	21	36	3,6	0,5	2,5	1	■	
02451587	410TL050R050-MEGA-T	2	G	5,0	6	7	65	26	36	4,5	0,5	1,5	1	■	
02451592	410TL060R050-MEGA-T	2	E	6,0	6	8	70	31	36	5,3	0,5	-	1	■	

■ Stock standard. Subject to change refer to current price- and stock-list

Cutting data – JH410 Slot milling

SMG		a _p /DC	f _z												v _c
			2	3	4	5	6	7	9	11	13	15	17		
N1	E/M/A	0,75	0,055	0,080	0,11	0,14	0,16	0,19	0,24	0,30	0,36	0,40	0,46	630 (520 — 730)	
N11	E/M/A	0,36	0,018	0,028	0,036	0,046	0,055	0,065	0,080	0,10	0,12	0,14	0,15	420 (315 — 530)	
TS1	A	1,0	0,055	0,080	0,11	0,14	0,16	0,19	0,24	0,30	0,36	0,40	0,46	630 (520 — 730)	

Cutting data – JH410 Side milling roughing

SMG		a _e /DC	a _p /DC	f _z												v _c
				2	3	4	5	6	7	9	11	13	15	17		
N1	E/M/A	0,41	1,0	0,070	0,11	0,14	0,18	0,22	0,26	0,32	0,40	0,46	0,50	0,55	710 (590 — 830)	
N11	E/M/A	0,32	0,64	0,026	0,040	0,055	0,065	0,080	0,095	0,12	0,15	0,17	0,19	0,22	495 (370 — 620)	
TS1	A	0,41	1,0	0,070	0,11	0,14	0,18	0,22	0,26	0,32	0,40	0,46	0,50	0,55	710 (590 — 830)	

For cutting data recalculations, see page 411-418.

SMG = Seco material group

Coolant = A=air D=dry E=emulsion M=mist spray

v_c = m/min

f_z = mm

a_p (mm)/DC (mm) = factor

a_e (mm)/DC (mm) = factor

All cutting data are target values

Cutting data – JH830 Slot milling

SMG		a _p /DC	f _z										v _c
			2	3	4	5	6	8	10	12			
N2	E	0,35	0,012	0,018	0,024	0,030	0,036	0,048	0,060	0,070	260 (205 – 310)		
N3	E	0,35	0,012	0,018	0,024	0,030	0,036	0,048	0,060	0,070	175 (140 – 205)		

Cutting data – JH830 Side milling

SMG		a _e /DC	a _p /DC	f _z										v _c
				2	3	4	5	6	8	10	12			
N2	E	0,15	1,0	0,020	0,030	0,040	0,050	0,060	0,080	0,10	0,12	350 (280 – 425)		
N3	E	0,15	1,0	0,020	0,030	0,040	0,050	0,060	0,080	0,10	0,12	235 (190 – 280)		

For cutting data recalculations, see page 411-418.

SMG = Seco material group

Coolant = A=air D=dry E=emulsion M=mist spray

v_c = m/min

f_z = mm

a_p (mm)/DC (mm)= factor

a_e (mm)/DC (mm)= factor

All cutting data are target values

Cutting data – JH440 Copy milling roughing

SMG		a _e /DC	a _p /DC	f _z						v _c
				6	8	10	12	16		
N1	E/M/A	0,30	0,50	0,080	0,12	0,085	0,11	0,13	780 (650 – 910)	
N2	E/M/A	0,30	0,50	0,060	0,090	0,070	0,090	0,11	510 (385 – 640)	
N3	E/M/A	0,30	0,50	0,060	0,090	0,070	0,090	0,11	340 (255 – 430)	
N11	E/M/A	0,30	0,50	0,060	0,090	0,065	0,080	0,095	255 (125 – 380)	
TS1	A	0,30	0,50	0,080	0,12	0,085	0,11	0,13	780 (650 – 910)	
TP1	A	0,30	0,60	0,070	0,044	0,060	0,075	0,090	510 (380 – 630)	

For cutting data recalculations, see page 411-418.

SMG = Seco material group

Coolant = A=air D=dry E=emulsion M=mist spray

v_c = m/min

f_z = mm

a_p (mm)/DC (mm)= factor

a_e (mm)/DC (mm)= factor

All cutting data are target values

Cutting data – JH450 Copy milling roughing

SMG		a _e /DC	a _p /DC	f _z											v _c
				2	3	4	5	6	8	10	12	16	20		
N1	E/M/A	0,40	0,25	0,040	0,060	0,080	0,10	0,12	0,16	0,20	0,24	0,32	0,40	690 (670 — 940)	
N2	E/M/A	0,30	0,25	0,040	0,060	0,080	0,10	0,12	0,16	0,20	0,24	0,32	0,40	470 (410 — 680)	
N3	E/M/A	0,30	0,25	0,040	0,060	0,080	0,10	0,12	0,16	0,20	0,24	0,32	0,40	315 (275 — 455)	
N11	E/M/A	0,30	0,25	0,040	0,060	0,080	0,10	0,12	0,16	0,20	0,24	0,32	0,36	470 (410 — 680)	
TS1	A	0,50	0,50	0,040	0,060	0,080	0,10	0,12	0,16	0,20	0,24	0,30	0,34	700 (620 — 870)	
TP1	M	0,30	0,25	0,040	0,060	0,080	0,10	0,12	0,16	0,20	0,24	0,32	0,36	470 (410 — 680)	

For cutting data recalculations, see page 411-418.

SMG = Seco material group

Coolant = A=air D=dry E=emulsion M=mist spray

v_c = m/min

f_z = mm

a_p (mm)/DC (mm)= factor

a_e (mm)/DC (mm)= factor

All cutting data are target values

Cutting data – JH460 Copy milling roughing

SMG		a _e /DC	a _p /DC	f _z								v _c
				3	4	5	6	8	10	12		
N1	E/M/A	0,50	0,20	0,055	0,075	0,095	0,11	0,15	0,19	0,22	590 (490 – 690)	
N11	E/M/A	0,30	0,20	0,046	0,060	0,080	0,095	0,12	0,16	0,18	610 (510 – 710)	
S11	E/M/A	0,30	0,20	0,032	0,044	0,055	0,065	0,090	0,11	0,13	120 (105 – 130)	
S12	E/M/A	0,30	0,20	0,032	0,044	0,055	0,065	0,090	0,11	0,13	90 (80 – 100)	
S13	E/M/A	0,30	0,17	0,032	0,042	0,050	0,065	0,085	0,10	0,12	75 (65 – 80)	
TS1	A	0,50	0,49	0,055	0,075	0,090	0,11	0,15	0,18	0,22	600 (500 – 700)	
TP1	M	0,30	0,20	0,046	0,060	0,080	0,095	0,12	0,16	0,18	405 (355 – 455)	

For cutting data recalculations, see page 411-418.

SMG = Seco material group

Coolant = A=air D=dry E=emulsion M=mist spray

v_c = m/min

f_z = mm

a_p (mm)/DC (mm)= factor

a_e (mm)/DC (mm)= factor

All cutting data are target values

Cutting data – JM403/JM404/406 Slot milling

SMG		a _e /DC	a _p /DC	f _z							v _c
				0,5	0,6	0,8	1,0	1,2	1,5	2,0	
N1	E	0,50	0,70	0,015	0,018	0,024	0,030	0,036	0,042	0,050	365 (305 – 425)
N2	E	0,50	0,70	0,015	0,018	0,024	0,030	0,036	0,042	0,050	235 (195 – 275)
N3	E	0,50	0,70	0,015	0,018	0,024	0,030	0,036	0,042	0,050	155 (130 – 180)

Cutting data – JM403/JM404/406 Side milling

SMG		a _e /DC	a _p /DC	f _z							v _c
				0,5	0,6	0,8	1,0	1,2	1,5	2,0	
N1	E	0,50	0,70	0,015	0,018	0,024	0,030	0,036	0,042	0,050	365 (305 – 425)
N2	E	0,50	0,70	0,015	0,018	0,024	0,030	0,036	0,042	0,050	235 (195 – 275)
N3	E	0,50	0,70	0,015	0,018	0,024	0,030	0,036	0,042	0,050	155 (130 – 180)

For cutting data recalculations, see page 411-418.

SMG = Seco material group

Coolant = A=air D=dry E=emulsion M=mist spray

v_c = m/min

f_z = mm

a_p (mm)/DC (mm) = factor

a_e (mm)/DC (mm) = factor

All cutting data are target values

Cutting data – JM413/416 Copy milling roughing

SMG		a _e /DC	a _p /DC	f _z								v _c
				0,5	0,6	0,8	1	1,2	1,5	2		
N1	E	0,30	0,30	0,030	0,036	0,048	0,060	0,070	0,085	0,10	385 (365 — 510)	
N2	E	0,30	0,30	0,030	0,036	0,048	0,060	0,070	0,085	0,10	245 (235 — 330)	
N3	E	0,30	0,30	0,030	0,036	0,048	0,060	0,070	0,085	0,10	165 (155 — 220)	
N11	E	0,30	0,30	0,030	0,036	0,048	0,060	0,070	0,085	0,10	320 (290 — 435)	
TS1	A	0,30	0,30	0,030	0,036	0,048	0,060	0,070	0,085	0,10	385 (365 — 510)	
TP1	A	0,30	0,30	0,030	0,036	0,048	0,060	0,070	0,085	0,10	385 (365 — 510)	

For cutting data recalculations, see page 411-418.

SMG = Seco material group

Coolant = A=air D=dry E=emulsion M=mist spray

v_c = m/min

f_z = mm

a_p (mm)/DC (mm)= factor

a_e (mm)/DC (mm)= factor

All cutting data are target values



Name		JHP170	JHF181	JH120	JH130	JH930	JH142	JH112
Page(s)		309-311	312-313	314-315	316-317	107, 107	164-166, 324-326	170-172, 328-330
Family name		HPM	HFM	HSM/TORNADO	HSM/TORNADO	HSM/TORNADO	HSM/TORNADO	HSM/TORNADO
Type of mill								
Shank	Cylindrical	■	■	■	■	■	■	■
	Weldon	■						
Number of Flutes		3-4	3-4-5	4	5-6, 8	5-6, 8	2-4-5-6	2
ICC			■					
Diameter range	Metric	2-20	1-10	2-16	6-20	6-20	2-12	2-12
	Inch							
Length availability								
Operation								
SMG								
H3		●	●	●	●	●	●	●
H5		●	●	●	●	●	●	●
H7		●	●	●	●	●	●	●
H8		●	●	●	●	●	●	●
H11		●	●	●	●	●		
H12		●	●	●	●	●		
H21		●		●	●	●	●	●
H31		●	●	●	●	●	●	●

■ Stock standard □ Weldon available, delivery time is 3 days.

● Preferred choice ○ Alternative choice

Name		JH150	JH160	JMB112	JME142	JME144
Page(s)		170, 170, 327	172, 172, 329	339 - 342	332 - 336	337 - 338
Family name		HSM/TORNADO	HSM/TORNADO	MINI	MINI	MINI
Type of mill						
Shank	Cylindrical	■	■	■	■	■
	Weldon					
Number of Flutes		4	4	2	2	4
Diameter range	Metric	6-12	3-12	0,2- 3,0	0,2- 3,0	1,0- 3,0
	Inch					
Length availability						
		2	2	1,2,3,4,5,6	1,2,3,4,5,6	2,3,4
Operation						
SMG						
H3		•	•	•	•	•
H5		•	•	•	•	•
H7		•	•	•	•	•
H8		•	•	•	•	•
H11		•	•	•	•	•
H12		•	•	•	•	•
H21		•	•	•	•	•
H31		•	•	•	•	•

■ Stock standard □ Weldon available, delivery time is 3 days.

• Preferred choice ○ Alternative choice

JHP170 – High performance – Hardened steel – Square – 3-4 Flutes – Cylindrical – Corner radius or chamfer



Tolerances:
 DMM= h5
 DC= -0,02/-0,04 mm
 CHW= Ø2- Ø4=+0,05 mm
 CHW= Ø5-Ø16=+0,1 mm
 RE= ±0,05 mm
 Regrind possible if DC is ≥Ø6

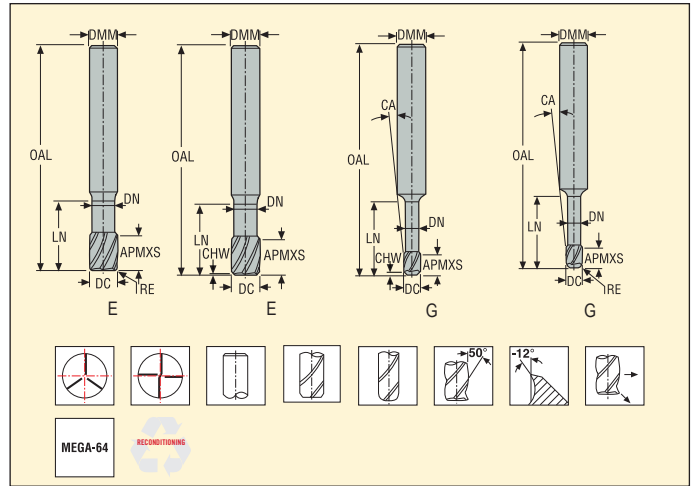

Ordering and Product No.	Designation	Length index	Tool shape	Dimensions in mm									PCEDC	Cylindrical
				DC	DMM	APMXS	OAL	LN	DN	RE	CHW	CA		
02462685	170020.0-MEGA-64	2	G	2,0	6	2	50	4	1,9	–	0,08	14,5	3	■
02587615	170020R020.0-MEGA-64	2	G	2,0	6	2	50	4	1,9	0,2	–	14,5	3	■
02587617	170020R050.0-MEGA-64	2	G	2,0	6	2	50	4	1,9	0,5	–	15,0	3	■
02462686	170030.0-MEGA-64	2	G	3,0	6	3	50	6	2,8	–	0,08	9,0	3	■
02587618	170030R020.0-MEGA-64	2	G	3,0	6	3	50	6	2,8	0,2	–	9,5	3	■
02587619	170030R050.0-MEGA-64	2	G	3,0	6	3	50	6	2,8	0,5	–	9,5	3	■
02462687	170040.0-MEGA-64	2	G	4,0	6	4	50	8	3,7	–	0,1	5,5	4	■
02587620	170040R020.0-MEGA-64	2	G	4,0	6	4	50	8	3,7	0,2	–	5,5	4	■
02587621	170040R050.0-MEGA-64	2	G	4,0	6	4	50	8	3,7	0,5	–	5,5	4	■
02462688	170050.0-MEGA-64	2	G	5,0	6	5	50	10	4,6	–	0,12	2,5	4	■
02587622	170050R020.0-MEGA-64	2	G	5,0	6	5	50	10	4,6	0,2	–	2,5	4	■
02587623	170050R050.0-MEGA-64	2	G	5,0	6	5	50	10	4,6	0,5	–	2,5	4	■
02462689	170060.0-MEGA-64	2	E	6,0	6	6	50	12	5,6	–	0,14	–	4	■
02587624	170060R020.0-MEGA-64	2	E	6,0	6	6	50	12	5,6	0,2	–	–	4	■
02587625	170060R050.0-MEGA-64	2	E	6,0	6	6	50	12	5,6	0,5	–	–	4	■
02462690	170080.0-MEGA-64	2	E	8,0	8	8	55	16	7,4	–	0,16	–	4	■
02587626	170080R020.0-MEGA-64	2	E	8,0	8	8	55	16	7,4	0,2	–	–	4	■
02587627	170080R050.0-MEGA-64	2	E	8,0	8	8	55	16	7,4	0,5	–	–	4	■
02587628	170080R100.0-MEGA-64	2	E	8,0	8	8	55	16	7,4	1,0	–	–	4	■
02462691	170100.0-MEGA-64	2	E	10,0	10	10	65	22	9,4	–	0,18	–	4	■
02587629	170100R050.0-MEGA-64	2	E	10,0	10	10	65	22	9,4	0,5	–	–	4	■
02587630	170100R100.0-MEGA-64	2	E	10,0	10	10	65	22	9,4	1,0	–	–	4	■
02462692	170120.0-MEGA-64	2	E	12,0	12	12	75	27	11,4	–	0,2	–	4	■
02587631	170120R050.0-MEGA-64	2	E	12,0	12	12	75	27	11,4	0,5	–	–	4	■
02587632	170120R100.0-MEGA-64	2	E	12,0	12	12	75	27	11,4	1,0	–	–	4	■
02462693	170160.0-MEGA-64	2	E	16,0	16	16	80	29	15,4	–	0,3	–	4	■
02587633	170160R050.0-MEGA-64	2	E	16,0	16	16	80	29	15,4	0,5	–	–	4	■
02587634	170160R100.0-MEGA-64	2	E	16,0	16	16	80	29	15,4	1,0	–	–	4	■

■ Stock standard. Subject to change refer to current price- and stock-list

JHP170 – High performance – Hardened steel – Square – 3-4 Flutes – Weldon – Corner radius or chamfer



Tolerances:
 DMM= h5
 DC= -0,02/-0,04 mm
 CHW= Ø2-Ø4=+0,05 mm
 CHW= Ø5-Ø16= +0,1 mm
 RE= ±0,05 mm
 Regrind possible if DC is ≥Ø6

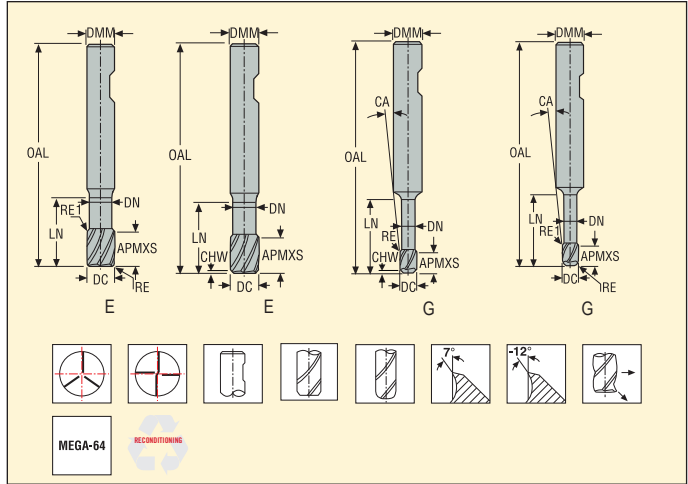

Ordering and Product No.	Designation	Length index	Tool shape	Dimensions in mm								PCEDC	Weldon	
				DC	DMM	APMX	OAL	LN	DN	RE	CHW			CA
02452924	170020-MEGA-64	2	G	2,0	6	2	50	4,0	1,9	-	0,08	14,5	3	■
02669319	170020R020.0-MEGA-64W	2	G	2,0	6	2	50	4,0	1,9	0,2	-	-	3	□
02669320	170020R050.0-MEGA-64W	2	G	2,0	6	2	50	4,0	1,9	0,5	-	-	3	□
02452925	170030-MEGA-64	2	G	3,0	6	3	50	6,0	2,8	-	0,08	9,0	3	■
02669321	170030R020.0-MEGA-64W	2	G	3,0	6	3	50	6,0	2,8	0,2	-	-	3	□
02669322	170030R050.0-MEGA-64W	2	G	3,0	6	3	50	6,0	2,8	0,5	-	-	3	□
02452927	170040-MEGA-64	2	G	4,0	6	4	50	8,0	3,7	-	0,1	5,5	4	■
02669323	170040R020.0-MEGA-64W	2	G	4,0	6	4	50	8,0	3,7	0,2	-	-	4	□
02669324	170040R050.0-MEGA-64W	2	G	4,0	6	4	50	8,0	3,7	0,5	-	-	4	□
02452928	170050-MEGA-64	2	G	5,0	6	5	50	10,0	4,6	-	0,12	2,5	4	■
02669325	170050R020.0-MEGA-64W	2	G	5,0	6	5	50	10,0	4,6	0,2	-	-	4	□
02669326	170050R050.0-MEGA-64W	2	G	5,0	6	5	50	10,0	4,6	0,5	-	-	4	□
02452929	170060-MEGA-64	2	E	6,0	6	6	50	11,5	5,6	-	0,14	-	4	■
02669327	170060R020.0-MEGA-64W	2	E	6,0	6	6	50	11,5	5,6	0,2	-	-	4	□
02669328	170060R050.0-MEGA-64W	2	E	6,0	6	6	50	11,5	5,6	0,5	-	-	4	□
02452930	170080-MEGA-64	2	E	8,0	8	8	55	16,0	7,4	-	0,16	-	4	■
02669329	170080R020.0-MEGA-64W	2	E	8,0	8	8	55	16,0	7,4	0,2	-	-	4	□
02669331	170080R050.0-MEGA-64W	2	E	8,0	8	8	55	16,0	7,4	0,5	-	-	4	□
02669332	170080R100.0-MEGA-64W	2	E	8,0	8	8	55	16,0	7,4	1,0	-	-	4	□
02452931	170100-MEGA-64	2	E	10,0	10	10	65	22,0	9,4	-	0,18	-	4	■
02669333	170100R050.0-MEGA-64W	2	E	10,0	10	10	65	22,0	9,4	0,5	-	-	4	□
02669334	170100R100.0-MEGA-64W	2	E	10,0	10	10	65	22,0	9,4	1,0	-	-	4	□
02452932	170120-MEGA-64	2	E	12,0	12	12	75	27,0	11,4	-	0,2	-	4	■
02669335	170120R050.0-MEGA-64W	2	E	12,0	12	12	75	27,0	11,4	0,5	-	-	4	□
02669336	170120R100.0-MEGA-64W	2	E	12,0	12	12	75	27,0	11,4	1,0	-	-	4	□
02452933	170160-MEGA-64	2	E	16,0	16	16	80	29,0	15,4	-	0,3	-	4	■
02669337	170160R050.0-MEGA-64W	2	E	16,0	16	16	80	29,0	15,4	0,5	-	-	4	□
02669338	170160R100.0-MEGA-64W	2	E	16,0	16	16	80	29,0	15,4	1,0	-	-	4	□
02611637	170200R050-MEGA-64	2	E	20,0	20	20	100	40,0	19,2	0,5	-	-	4	■
02611638	170200R100-MEGA-64	2	E	20,0	20	20	100	40,0	19,2	1,0	-	-	4	■

■ Stock standard. Subject to change refer to current price- and stock-list □ Weldon available, delivery time is 3 days.

Cutting data – JHP170 Slot milling

SMG		a_p/DC	f_z										v_c
			2	3	4	5	6	8	10	12	16	20	
H3	M	0,40	0,0040	0,0060	0,0080	0,010	0,012	0,016	0,020	0,024	0,030	0,034	15 (10 – 20)
H5	M	0,70	0,0080	0,012	0,016	0,020	0,024	0,032	0,040	0,050	0,065	0,080	50 (46 – 55)
H7	M	0,35	0,0040	0,0060	0,0080	0,010	0,012	0,016	0,020	0,024	0,030	0,034	15 (10 – 20)
H8	M	0,60	0,0080	0,012	0,016	0,020	0,024	0,032	0,040	0,050	0,065	0,080	50 (46 – 55)
H11	M	0,70	0,0080	0,012	0,016	0,020	0,024	0,032	0,040	0,050	0,065	0,080	65 (60 – 70)
H12	M	0,60	0,0080	0,012	0,016	0,020	0,024	0,032	0,040	0,050	0,065	0,080	60 (55 – 65)
H21	M	0,60	0,0080	0,012	0,016	0,020	0,024	0,032	0,040	0,050	0,065	0,080	50 (46 – 55)
H31	M	0,60	0,0080	0,012	0,016	0,020	0,024	0,032	0,040	0,050	0,065	0,080	46 (41 – 50)

Cutting data – JHP170 Side milling

SMG		a_e/DC	a_p/DC	f_z										v_c
				2	3	4	5	6	8	10	12	16	20	
H3	M	0,15	0,60	0,0055	0,0085	0,011	0,014	0,017	0,022	0,028	0,034	0,042	0,048	22 (15 – 29)
H5	M	0,30	0,80	0,016	0,024	0,032	0,040	0,048	0,065	0,080	0,095	0,12	0,13	60 (55 – 65)
H7	M	0,15	0,50	0,0055	0,0085	0,011	0,014	0,017	0,022	0,028	0,034	0,042	0,048	22 (15 – 29)
H8	M	0,30	0,80	0,012	0,018	0,024	0,030	0,036	0,048	0,060	0,070	0,090	0,10	65 (55 – 70)
H11	M	0,30	0,80	0,016	0,024	0,032	0,040	0,048	0,065	0,080	0,095	0,12	0,13	75 (65 – 80)
H12	M	0,30	0,80	0,012	0,018	0,024	0,030	0,036	0,048	0,060	0,070	0,090	0,10	75 (65 – 80)
H21	M	0,30	0,80	0,012	0,018	0,024	0,030	0,036	0,048	0,060	0,070	0,090	0,10	65 (55 – 70)
H31	M	0,30	0,80	0,012	0,018	0,024	0,030	0,036	0,048	0,060	0,070	0,090	0,10	55 (50 – 65)

For cutting data recalculations, see page 411-418.

SMG = Seco material group

Coolant = A=air D=dry E=emulsion M=mist spray

v_c = m/min

f_z = mm

a_p (mm)/DC (mm)= factor

a_e (mm)/DC (mm)= factor

All cutting data are target values

JHF181 - High feed - Hardened steel - Square - 3-5 Flutes - Cylindrical - Corner radius - ICC



Tolerances:
 DMM=h5
 DC= -0,02/-0,04 mm
 RE= ±0,01 mm
 Regrind possible if DC is ≥Ø6

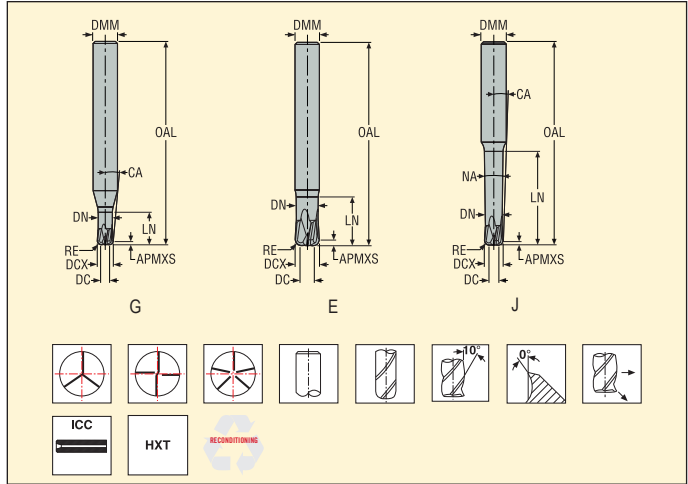

Ordering and Product No.	Designation	Length index	Tool shape	ICC	Dimensions in mm										RE	PCEDC	Cylindrical
					DC	DCX	DMM	APMXS	OAL	LN	DN	CA	NA				
03067297	JHF181020G1R050.0Z4-HXT	1	G		1,0	2	6	0,5	50	4	1,8	10,0	15,0	0,5	4	■	
03067298	JHF181030G1R075.0Z4-HXT	1	G		1,5	3	6	0,75	50	6	2,7	7,5	15,0	0,75	4	■	
03067299	JHF181040G1R100.0Z4-HXT	1	G		2,0	4	6	1,0	50	8	3,6	5,0	15,0	1,0	4	■	
03067300	JHF181060E1R150.0Z4-HXT	1	E		3,0	6	6	1,5	50	12	5,4	-	0,0	1,5	4	■	
03067301	JHF181080E1R200.0Z4-HXT	1	E		4,0	8	8	2,0	55	16	7,3	-	0,0	2,0	4	■	
03067302	JHF181100E1R200.0Z4-HXT	1	E		6,0	10	10	2,0	65	20	9,2	-	0,0	2,0	4	■	
03067303	JHF181100E1R200.0Z5-HXT	1	E		6,0	10	10	2,0	65	20	9,2	-	0,0	2,0	5	■	
03067304	JHF181120E1R300.0Z4-HXT	1	E		6,0	12	12	3,0	75	24	11,0	-	0,0	3,0	4	■	
03067305	JHF181120E1R300.0Z5-HXT	1	E		6,0	12	12	3,0	75	24	11,0	-	0,0	3,0	5	■	
03067306	JHF181160E1R300.0Z4-HXT	1	E		10,0	16	16	3,0	80	32	14,8	-	0,0	3,0	4	■	
03067307	JHF181020G2R050.0Z4-HXT	2	G		1,0	2	6	0,5	50	8	1,8	7,5	15,0	0,5	4	■	
03067308	JHF181030G2R075.0Z4-HXT	2	G		1,5	3	6	0,75	50	12	2,7	5,0	15,0	0,75	4	■	
03067309	JHF181040G2R100.0Z4-HXT	2	G		2,0	4	6	1,0	50	16	3,6	3,0	15,0	1,0	4	■	
03067311	JHF181060E2R150.0Z4A-HXT	2	E	■	3,0	6	6	1,5	65	24	5,4	-	0,0	1,5	4	■	
03067310	JHF181060E2R150.0Z4-HXT	2	E		3,0	6	6	1,5	65	24	5,4	-	0,0	1,5	4	■	
03067313	JHF181080E2R200.0Z4A-HXT	2	E	■	4,0	8	8	2,0	70	32	7,3	-	0,0	2,0	4	■	
03067312	JHF181080E2R200.0Z4-HXT	2	E		4,0	8	8	2,0	70	32	7,3	-	0,0	2,0	4	■	
03067315	JHF181100E2R200.0Z4A-HXT	2	E	■	6,0	10	10	2,0	85	40	9,2	-	0,0	2,0	4	■	
03067314	JHF181100E2R200.0Z4-HXT	2	E		6,0	10	10	2,0	85	40	9,2	-	0,0	2,0	4	■	
03067317	JHF181120E2R300.0Z4A-HXT	2	E	■	6,0	12	12	3,0	100	48	11,0	-	0,0	3,0	4	■	
03067316	JHF181120E2R300.0Z4-HXT	2	E		6,0	12	12	3,0	100	48	11,0	-	0,0	3,0	4	■	
03067318	JHF181020J3R050.0Z4-HXT	3	J		1,0	2	6	0,5	50	10	1,8	6,8	0,9	0,5	4	■	
03067319	JHF181030J3R075.0Z4-HXT	3	J		1,5	3	6	0,75	50	15	2,7	4,4	0,9	0,75	4	■	
03067320	JHF181040J3R100.0Z4-HXT	3	J		2,0	4	6	1,0	60	20	3,6	2,6	0,9	1,0	4	■	
03067323	JHF181060J3R150.0Z4A-HXT	3	J	■	3,0	6	8	1,5	65	30	5,4	1,9	0,9	1,5	4	■	
03067321	JHF181060J3R150.0Z4-HXT	3	J		3,0	6	8	1,5	65	30	5,4	1,9	0,9	1,5	4	■	
03067326	JHF181080J3R200.0Z4A-HXT	3	J	■	4,0	8	10	2,0	85	40	7,3	1,5	0,9	2,0	4	■	
03067325	JHF181080J3R200.0Z4-HXT	3	J		4,0	8	10	2,0	85	40	7,3	1,5	0,9	2,0	4	■	
03067328	JHF181100J3R200.0Z4A-HXT	3	J	■	6,0	10	12	2,0	100	50	9,2	1,2	0,9	2,0	4	■	
03067327	JHF181100J3R200.0Z4-HXT	3	J		6,0	10	12	2,0	100	50	9,2	1,2	0,9	2,0	4	■	
03067329	JHF181020J4R050.0Z3-HXT	4	J		1,0	2	6	0,5	50	14	1,8	5,6	0,9	0,5	3	■	
03067330	JHF181030J4R075.0Z3-HXT	4	J		1,5	3	6	0,75	60	21	2,7	3,4	0,9	0,75	3	■	
03067331	JHF181040J4R100.0Z3-HXT	4	J		2,0	4	6	1,0	65	28	3,6	2,0	0,9	1,0	3	■	
03067332	JHF181060J4R150.0Z3-HXT	4	J		3,0	6	8	1,5	80	42	5,4	1,4	0,9	1,5	3	■	
03067333	JHF181080J4R200.0Z3-HXT	4	J		4,0	8	10	2,0	100	56	7,3	1,1	0,9	2,0	3	■	
03067334	JHF181100J4R200.0Z3-HXT	4	J		6,0	10	12	2,0	125	70	9,2	0,9	0,9	2,0	3	■	

■ Stock standard. Subject to change refer to current price- and stock-list

Cutting data – JHF181 Slot milling

SMG		a _p /DC	f _z (Based on DC)									v _c
			2	3	4	6	8	10	12	16		
P6	E/M/A	0,053	0,070	0,11	0,14	0,22	0,11	0,36	0,44	0,60	185 (160 – 215)	
P7	E/M/A	0,053	0,070	0,11	0,14	0,22	0,11	0,36	0,44	0,60	175 (150 – 200)	
P8	E/M/A	0,053	0,070	0,11	0,14	0,22	0,12	0,36	0,44	0,60	165 (145 – 190)	
P11	E/M/A	0,053	0,070	0,11	0,14	0,22	0,11	0,36	0,44	0,60	170 (145 – 195)	
K1	E/M/A	0,053	0,070	0,11	0,14	0,22	0,11	0,36	0,44	0,60	120 (95 – 145)	
K2	E/M/A	0,053	0,070	0,11	0,14	0,22	0,10	0,36	0,44	0,60	105 (85 – 125)	
K3	E/M/A	0,053	0,070	0,11	0,14	0,22	0,10	0,36	0,44	0,60	85 (70 – 105)	
K4	E/M/A	0,053	0,070	0,11	0,14	0,22	0,10	0,36	0,44	0,60	85 (65 – 100)	
K5	E/M/A	0,053	0,050	0,075	0,10	0,15	0,10	0,26	0,30	0,40	65 (55 – 75)	
K6	E/M/A	0,053	0,050	0,075	0,10	0,15	0,11	0,26	0,30	0,40	100 (85 – 115)	
K7	E/M/A	0,053	0,050	0,075	0,10	0,15	0,10	0,26	0,30	0,40	85 (75 – 100)	
H3	M/A/D	0,030	0,055	0,085	0,11	0,17	0,070	0,28	0,34	0,46	130 (115 – 145)	
H5	M/A/D	0,053	0,070	0,11	0,14	0,22	0,11	0,36	0,44	0,60	130 (115 – 145)	
H7	M/A/D	0,027	0,055	0,085	0,11	0,17	0,070	0,28	0,34	0,46	130 (115 – 145)	
H8	M/A/D	0,047	0,070	0,11	0,14	0,22	0,085	0,36	0,44	0,60	130 (115 – 145)	
H11	M/A/D	0,053	0,070	0,11	0,14	0,22	0,11	0,36	0,44	0,60	165 (145 – 185)	
H12	M/A/D	0,047	0,070	0,11	0,14	0,22	0,085	0,36	0,44	0,60	155 (135 – 170)	
H21	M/A/D	0,047	0,070	0,11	0,14	0,22	0,085	0,36	0,44	0,60	130 (115 – 145)	
H31	M/A/D	0,047	0,070	0,11	0,14	0,22	0,075	0,36	0,44	0,60	100 (90 – 110)	

Cutting data – JHF181 Side milling roughing

SMG		a _p /DCX	a _p /DC	f _z (Based on DC)									v _c
				2	3	4	6	8	10	12	16		
P6	E/M/A	0,30	0,053	0,19	0,28	0,38	0,34	0,12	0,85	0,90	1,0	230 (200 – 265)	
P7	E/M/A	0,30	0,053	0,19	0,28	0,38	0,34	0,12	0,85	0,90	1,0	220 (190 – 250)	
P8	E/M/A	0,30	0,053	0,20	0,30	0,40	0,36	0,13	0,90	0,90	1,0	200 (175 – 230)	
P11	E/M/A	0,30	0,053	0,19	0,28	0,38	0,34	0,12	0,85	0,90	1,0	215 (180 – 245)	
K1	E/M/A	0,30	0,053	0,19	0,28	0,38	0,34	0,12	0,85	0,90	1,0	145 (120 – 175)	
K2	E/M/A	0,30	0,053	0,17	0,26	0,34	0,32	0,11	0,75	0,80	0,90	130 (105 – 155)	
K3	E/M/A	0,30	0,053	0,17	0,26	0,34	0,32	0,11	0,75	0,80	0,90	110 (90 – 135)	
K4	E/M/A	0,30	0,053	0,17	0,26	0,34	0,32	0,11	0,75	0,80	0,90	105 (85 – 125)	
K5	E/M/A	0,30	0,053	0,15	0,22	0,30	0,32	0,11	0,75	0,80	0,90	80 (70 – 90)	
K6	E/M/A	0,30	0,053	0,15	0,22	0,30	0,34	0,12	0,75	0,90	1,0	120 (105 – 135)	
K7	E/M/A	0,30	0,053	0,15	0,22	0,30	0,32	0,11	0,75	0,80	0,90	105 (90 – 120)	
H3	M/A/D	0,30	0,030	0,11	0,17	0,22	0,28	0,075	0,50	0,55	0,60	170 (150 – 190)	
H5	M/A/D	0,30	0,053	0,19	0,28	0,38	0,34	0,12	0,85	0,90	1,0	160 (145 – 180)	
H7	M/A/D	0,30	0,027	0,11	0,17	0,22	0,30	0,075	0,50	0,55	0,60	170 (155 – 190)	
H8	M/A/D	0,30	0,047	0,14	0,22	0,28	0,28	0,095	0,65	0,70	0,75	175 (155 – 195)	
H11	M/A/D	0,30	0,053	0,19	0,28	0,38	0,34	0,12	0,85	0,90	1,0	205 (180 – 225)	
H12	M/A/D	0,30	0,047	0,14	0,22	0,28	0,28	0,095	0,65	0,70	0,75	200 (180 – 225)	
H21	M/A/D	0,30	0,047	0,14	0,22	0,28	0,28	0,095	0,65	0,70	0,75	175 (155 – 195)	
H31	M/A/D	0,30	0,047	0,12	0,18	0,24	0,24	0,080	0,55	0,60	0,65	135 (120 – 150)	

For cutting data recalculations, see page 411-418.

SMG = Seco material group

Coolant = A=air D=dry E=emulsion M=mist spray

v_c = m/min

f_z = mm

a_p (mm)/DC (mm) = factor

a_e (mm)/DC (mm) = factor

All cutting data are target values

Cutting data – JH120 Slot milling

SMG		a _p /DC	f _z											v _c
			2	2,5	3	3,5	4	5	6	8	10	12	16	
H3	M	0,050	0,0036	0,0044	0,0055	0,0065	0,0070	0,0090	0,011	0,014	0,018	0,022	0,026	55 (35 – 80)
H5	M	0,18	0,0080	0,010	0,012	0,014	0,016	0,020	0,024	0,032	0,040	0,048	0,060	120 (95 – 140)
H7	M	0,044	0,0038	0,0048	0,0060	0,0065	0,0075	0,0095	0,012	0,015	0,019	0,022	0,028	55 (35 – 80)
H8	M	0,16	0,0065	0,0080	0,0095	0,011	0,013	0,016	0,019	0,026	0,032	0,038	0,046	125 (100 – 145)
H11	M	0,18	0,0080	0,010	0,012	0,014	0,016	0,020	0,024	0,032	0,040	0,048	0,060	150 (125 – 180)
H12	M	0,16	0,0065	0,0080	0,0095	0,011	0,013	0,016	0,019	0,026	0,032	0,038	0,046	145 (120 – 170)
H21	M	0,16	0,0065	0,0080	0,0095	0,011	0,013	0,016	0,019	0,026	0,032	0,038	0,046	125 (100 – 145)
H31	M	0,18	0,0080	0,010	0,012	0,014	0,016	0,020	0,024	0,032	0,040	0,048	0,060	75 (65 – 85)

Cutting data – JH120 Side milling

SMG		a _e /DC	a _p /DC	f _z											v _c
				2	2,5	3	3,5	4	5	6	8	10	12	16	
H3	M	0,015	0,50	0,0065	0,0085	0,010	0,012	0,013	0,017	0,020	0,026	0,034	0,040	0,048	95 (55 – 135)
H5	M	0,030	1,0	0,012	0,015	0,018	0,020	0,024	0,030	0,036	0,048	0,060	0,070	0,095	215 (175 – 255)
H7	M	0,015	0,50	0,0065	0,0085	0,010	0,012	0,013	0,017	0,020	0,026	0,034	0,040	0,048	95 (55 – 135)
H8	M	0,030	1,0	0,012	0,015	0,018	0,020	0,024	0,030	0,036	0,048	0,060	0,070	0,095	215 (175 – 255)
H11	M	0,030	1,0	0,012	0,015	0,018	0,020	0,024	0,030	0,036	0,048	0,060	0,070	0,095	275 (225 – 320)
H12	M	0,030	1,0	0,012	0,015	0,018	0,020	0,024	0,030	0,036	0,048	0,060	0,070	0,095	250 (205 – 295)
H21	M	0,030	1,0	0,012	0,015	0,018	0,020	0,024	0,030	0,036	0,048	0,060	0,070	0,095	215 (175 – 255)
H31	M	0,030	1,0	0,010	0,012	0,015	0,018	0,020	0,024	0,030	0,040	0,050	0,060	0,080	140 (120 – 160)

For cutting data recalculations, see page 411-418.

SMG = Seco material group

Coolant = A=air D=dry E=emulsion M=mist spray

v_c = m/min

f_z = mm

a_p (mm)/DC (mm)= factor

a_e (mm)/DC (mm)= factor

All cutting data are target values

Cutting data – JH130 Side milling finishing

SMG		a _e /DC	a _p /DC	f _z							v _c
				6	8	10	12	16	20		
H3	M	0,030	0,50	0,013	0,018	0,022	0,026	0,032	0,038	85 (70 – 95)	
H5	M	0,030	1,0	0,032	0,042	0,050	0,060	0,075	0,090	255 (235 – 275)	
H7	M	0,030	0,50	0,013	0,018	0,022	0,026	0,032	0,038	85 (70 – 95)	
H8	M	0,030	1,0	0,024	0,032	0,040	0,046	0,060	0,065	260 (235 – 280)	
H11	M	0,030	1,0	0,032	0,042	0,050	0,060	0,075	0,090	320 (295 – 350)	
H12	M	0,030	1,0	0,024	0,032	0,040	0,046	0,060	0,065	300 (275 – 325)	
H21	M	0,030	1,0	0,024	0,032	0,040	0,046	0,060	0,065	260 (235 – 280)	
H31	M	0,030	1,0	0,030	0,040	0,050	0,060	0,075	0,085	155 (135 – 175)	

Cutting data – JH130 Side milling roughing

SMG		a _e /DC	a _p /DC	f _z							v _c
				6	8	10	12	16	20		
H3	M	0,030	0,50	0,013	0,018	0,022	0,026	0,032	0,038	85 (70 – 95)	
H5	M	0,030	1,0	0,032	0,042	0,050	0,060	0,075	0,090	255 (235 – 275)	
H7	M	0,030	0,50	0,013	0,018	0,022	0,026	0,032	0,038	85 (70 – 95)	
H8	M	0,030	1,0	0,024	0,032	0,040	0,046	0,060	0,065	260 (235 – 280)	
H11	M	0,030	1,0	0,032	0,042	0,050	0,060	0,075	0,090	320 (295 – 350)	
H12	M	0,030	1,0	0,024	0,032	0,040	0,046	0,060	0,065	300 (275 – 325)	
H21	M	0,030	1,0	0,024	0,032	0,040	0,046	0,060	0,065	260 (235 – 280)	
H31	M	0,030	1,0	0,030	0,040	0,050	0,060	0,075	0,085	155 (135 – 175)	

For cutting data recalculations, see page 411-418.

SMG = Seco material group

Coolant = A=air D=dry E=emulsion M=mist spray

v_c = m/min

f_z = mm

a_p (mm)/DC (mm)= factor

a_e (mm)/DC (mm)= factor

All cutting data are target values

Cutting data – JH930 Side milling semi finishing

SMG		a _e /DC	a _p /DC	f _z						
				6	8	10	12	16	20	
P1	M/E/A	0.040	0.70	0.065	0.085	0.11	0.13	0.16	0.18	460 (385 – 520)
P2	M/E/A	0.040	0.70	0.065	0.090	0.11	0.13	0.16	0.19	445 (375 – 510)
P3	M/E/A	0.040	0.70	0.065	0.085	0.11	0.12	0.15	0.18	385 (325 – 435)
P4	M/E/A	0.040	0.70	0.060	0.080	0.10	0.12	0.15	0.17	345 (290 – 390)
P5	M/E/A	0.040	0.70	0.060	0.080	0.10	0.12	0.15	0.17	330 (275 – 370)
P6	M/E/A	0.040	0.70	0.060	0.080	0.10	0.12	0.15	0.17	370 (310 – 415)
P7	M/E/A	0.040	0.70	0.060	0.080	0.10	0.12	0.15	0.17	350 (290 – 395)
P8	M/E/A	0.040	0.70	0.065	0.085	0.11	0.12	0.15	0.18	325 (270 – 365)
P11	M/E/A	0.040	0.70	0.060	0.080	0.10	0.12	0.15	0.17	340 (285 – 380)
P12	M/E/A	0.040	0.50	0.040	0.050	0.065	0.075	0.095	0.11	215 (180 – 245)
K1	E/M/A	0.040	0.70	0.060	0.080	0.10	0.12	0.15	0.17	265 (210 – 320)
K2	E/M/A	0.040	0.70	0.055	0.075	0.090	0.11	0.13	0.15	235 (185 – 280)
K3	E/M/A	0.040	0.70	0.055	0.075	0.090	0.11	0.13	0.15	200 (160 – 235)
K4	E/M/A	0.040	0.70	0.055	0.075	0.090	0.11	0.13	0.15	190 (150 – 225)
K5	E/M/A	0.030	0.50	0.060	0.080	0.10	0.12	0.15	0.17	215 (160 – 270)
K6	E/M/A	0.030	0.50	0.070	0.090	0.11	0.13	0.17	0.19	315 (235 – 395)
K7	E/M/A	0.030	0.50	0.060	0.080	0.10	0.12	0.15	0.17	275 (210 – 345)
S1	E/M/A	0.030	0.45	0.055	0.075	0.090	0.11	0.14	0.16	85 (65 – 110)
S2	E/M/A	0.030	0.45	0.055	0.075	0.090	0.11	0.14	0.16	70 (55 – 90)
S3	E/M/A	0.020	0.70	0.055	0.075	0.090	0.11	0.13	0.15	42 (32 – 55)
S11	E/M/A	0.040	0.70	0.060	0.080	0.10	0.12	0.15	0.17	165 (140 – 195)
S12	E/M/A	0.040	0.70	0.060	0.080	0.10	0.12	0.15	0.17	125 (105 – 150)
S13	E/M/A	0.040	0.60	0.055	0.070	0.090	0.10	0.13	0.15	100 (85 – 120)
H3	M/A	0.020	0.50	0.018	0.024	0.030	0.036	0.044	0.050	60 (43 – 75)
H5	M/A	0.030	0.50	0.024	0.032	0.040	0.048	0.060	0.070	265 (215 – 320)
H7	M/A	0.020	0.50	0.018	0.024	0.030	0.036	0.044	0.050	60 (43 – 75)
H8	M/A	0.030	0.45	0.017	0.022	0.028	0.034	0.042	0.048	275 (220 – 325)
H11	M/A	0.030	0.50	0.024	0.032	0.040	0.048	0.060	0.070	340 (270 – 405)
H12	M/A	0.040	0.45	0.024	0.030	0.038	0.046	0.055	0.065	300 (240 – 360)
H21	M/A	0.030	0.45	0.017	0.022	0.028	0.034	0.042	0.048	275 (220 – 325)
H31	M/A	0.030	0.50	0.024	0.032	0.040	0.048	0.060	0.070	165 (130 – 195)

For cutting data recalculations, see page 411-418.

SMG = Seco material group

Coolant = A=air D=dry E=emulsion M=mist spray

v_c = m/min

f_z = mm

a_p (mm)/DC (mm)= factor

a_e (mm)/DC (mm)= factor

All cutting data are target values

Cutting data – JH930 Side milling roughing

SMG		a _e /DC	a _p /DC	f _z							v _c
				6	8	10	12	16	20		
P1	M/E/A	0,040	0,70	0,065	0,085	0,11	0,13	0,16	0,18	440 (370 – 490)	
P2	M/E/A	0,040	0,70	0,065	0,090	0,11	0,13	0,16	0,19	430 (360 – 480)	
P3	M/E/A	0,040	0,70	0,060	0,085	0,10	0,12	0,15	0,18	375 (320 – 420)	
P4	M/E/A	0,040	0,70	0,060	0,080	0,10	0,12	0,15	0,17	330 (280 – 370)	
P5	M/E/A	0,040	0,70	0,060	0,080	0,10	0,12	0,15	0,17	315 (270 – 350)	
P6	M/E/A	0,040	0,70	0,060	0,080	0,10	0,12	0,15	0,17	355 (300 – 390)	
P7	M/E/A	0,040	0,70	0,060	0,080	0,10	0,12	0,15	0,17	335 (280 – 370)	
P8	M/E/A	0,040	0,70	0,060	0,085	0,10	0,12	0,15	0,18	315 (270 – 350)	
P11	M/E/A	0,040	0,70	0,060	0,080	0,10	0,12	0,15	0,17	325 (280 – 360)	
P12	M/E/A	0,040	0,50	0,038	0,050	0,065	0,075	0,095	0,11	205 (180 – 230)	
K1	E/M/A	0,040	0,70	0,060	0,080	0,10	0,12	0,15	0,17	255 (210 – 300)	
K2	E/M/A	0,040	0,70	0,055	0,075	0,090	0,11	0,13	0,15	225 (180 – 260)	
K3	E/M/A	0,040	0,70	0,055	0,075	0,090	0,11	0,13	0,15	190 (160 – 220)	
K4	E/M/A	0,040	0,70	0,055	0,075	0,090	0,11	0,13	0,15	180 (150 – 210)	
K5	E/M/A	0,030	0,50	0,060	0,080	0,10	0,12	0,15	0,17	205 (160 – 250)	
K6	E/M/A	0,030	0,50	0,065	0,090	0,11	0,13	0,16	0,19	300 (230 – 370)	
K7	E/M/A	0,030	0,50	0,060	0,080	0,10	0,12	0,15	0,17	260 (200 – 320)	
S1	E/M/A	0,030	0,44	0,055	0,070	0,090	0,11	0,13	0,15	80 (62 – 100)	
S2	E/M/A	0,030	0,44	0,055	0,070	0,090	0,11	0,13	0,15	65 (50 – 82)	
S3	E/M/A	0,020	0,70	0,055	0,070	0,090	0,11	0,13	0,15	41 (31 – 50)	
S11	E/M/A	0,040	0,70	0,060	0,080	0,10	0,12	0,15	0,17	160 (140 – 180)	
S12	E/M/A	0,040	0,70	0,060	0,080	0,10	0,12	0,15	0,17	120 (110 – 140)	
S13	E/M/A	0,040	0,60	0,050	0,070	0,085	0,10	0,13	0,15	95 (82 – 110)	
H5	M/A	0,030	0,50	0,024	0,032	0,040	0,048	0,060	0,070	250 (210 – 300)	
H8	M/A	0,030	0,44	0,017	0,022	0,028	0,034	0,042	0,048	260 (210 – 300)	
H11	M/A	0,030	0,50	0,024	0,032	0,040	0,048	0,060	0,070	320 (260 – 380)	
H12	M/A	0,040	0,44	0,022	0,030	0,038	0,044	0,055	0,065	280 (230 – 330)	
H21	M/A	0,030	0,44	0,017	0,022	0,028	0,034	0,042	0,048	260 (210 – 300)	
H31	M/A	0,030	0,50	0,024	0,032	0,040	0,048	0,060	0,070	155 (130 – 180)	

For cutting data recalculations, see page 411-418.

SMG = Seco material group

Coolant = A=air D=dry E=emulsion M=mist spray

v_c = m/min

f_z = mm

a_p (mm)/DC (mm)= factor

a_e (mm)/DC (mm)= factor

All cutting data are target values

JH142 – High speed – High precision – Torical – Hardened steel – 2-6 Flutes – Cylindrical – Corner radius



Tolerances:
 Run-out= <0,005 mm
 DMM= h5
 DC= 0-0,01 mm
 RE= ±0,005 mm
 Regrind possible if DC is ≥Ø6

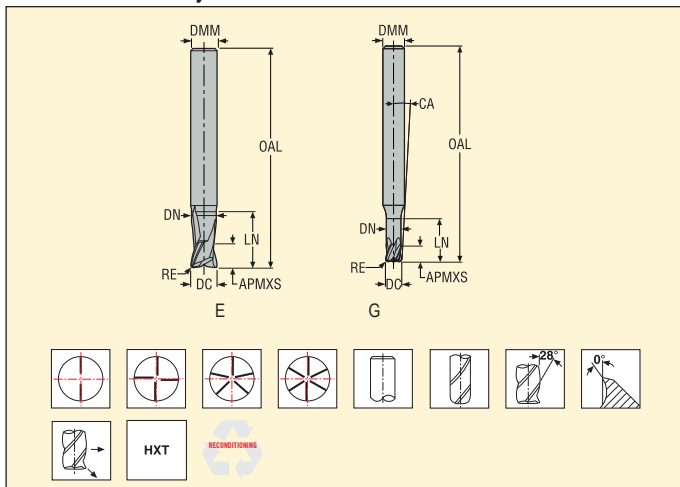

Ordering and Product No.	Designation	Length index	Tool shape	Dimensions in mm							RE	CA	PCEDC	Max. cut depth rel. to α _η (l _{αη} , ref)*					
				DC	DMM	APMXS	OAL	LN	DN	WDX0				WDX05	WDX1	WDX15	WDX2	WDX3	
02968223	JH142020G2R030.0Z2-HXT	2	G	2,0	4	2	40	6	1,9	0,3	6,64	2	6,63	6,96	7,21	7,43	7,62	7,96	
02968224	JH142020G2R030.0Z4-HXT	2	G	2,0	4	2	40	6	1,9	0,3	6,64	4	6,63	6,96	7,21	7,43	7,62	7,96	
02968225	JH142020G2R050.0Z2-HXT	2	G	2,0	4	2	40	6	1,9	0,5	6,79	2	6,63	6,95	7,2	7,41	7,6	7,93	
02968226	JH142020G2R050.0Z4-HXT	2	G	2,0	4	2	40	6	1,9	0,5	6,79	4	6,63	6,95	7,2	7,41	7,6	7,93	
02968227	JH142030G2R050.0Z2-HXT	2	G	3,0	4	3	40	8	2,8	0,5	2,95	2	8,92	9,23	9,48	9,71	9,91	10,26	
02968228	JH142030G2R050.0Z4-HXT	2	G	3,0	4	3	40	8	2,8	0,5	2,95	4	8,92	9,23	9,48	9,71	9,91	10,26	
02968229	JH142030G2R100.0Z2-HXT	2	G	3,0	4	3	40	8	2,8	1,0	3,1	2	8,92	9,21	9,46	9,67	9,87	10,21	
02968230	JH142030G2R100.0Z4-HXT	2	G	3,0	4	3	40	8	2,8	1,0	3,1	4	8,92	9,21	9,46	9,67	9,87	10,21	
02968231	JH142040G2R030.0Z2-HXT	2	G	4,0	6	4	50	8	3,7	0,3	5,34	2	9,13	9,4	9,64	9,84	10,03	10,37	
02970110	JH142040G2R030.0Z4-HXT	2	G	4,0	6	4	50	8	3,7	0,3	5,34	4	9,13	9,4	9,64	9,84	10,03	10,37	
02968232	JH142040G2R050.0Z4-HXT	2	G	4,0	6	4	50	8	3,7	0,5	5,44	4	9,13	9,4	9,63	9,83	10,02	10,35	
02968233	JH142040G2R100.0Z4-HXT	2	G	4,0	6	4	50	8	3,7	1,0	5,69	4	9,13	9,38	9,6	9,8	9,98	10,3	
02968234	JH142060E2R050.0Z2-HXT	2	E	6,0	6	6	50	12	5,6	0,5	-	2	12,0	∞	∞	∞	∞	∞	
02968235	JH142060E2R050.0Z4-HXT	2	E	6,0	6	6	50	12	5,6	0,5	-	4	12,0	∞	∞	∞	∞	∞	
02968236	JH142060E2R100.0Z2-HXT	2	E	6,0	6	6	50	12	5,6	1,0	-	2	12,0	∞	∞	∞	∞	∞	
02968237	JH142060E2R100.0Z4-HXT	2	E	6,0	6	6	50	12	5,6	1,0	-	4	12,0	∞	∞	∞	∞	∞	
02968238	JH142060E2R100.0Z5-HXT	2	E	6,0	6	6	50	12	5,6	1,0	-	5	12,0	∞	∞	∞	∞	∞	
02968239	JH142060E2R150.0Z2-HXT	2	E	6,0	6	6	50	12	5,6	1,5	-	2	12,0	∞	∞	∞	∞	∞	
02968240	JH142060E2R150.0Z5-HXT	2	E	6,0	6	6	50	12	5,6	1,5	-	5	12,0	∞	∞	∞	∞	∞	
02968241	JH142060E2R200.0Z5-HXT	2	E	6,0	6	6	50	12	5,6	2,0	-	5	12,0	∞	∞	∞	∞	∞	
02968242	JH142080E2R050.0Z5-HXT	2	E	8,0	8	8	60	16	7,4	0,5	-	5	16,0	∞	∞	∞	∞	∞	
02968243	JH142080E2R100.0Z5-HXT	2	E	8,0	8	8	60	16	7,4	1,0	-	5	16,0	∞	∞	∞	∞	∞	
02968244	JH142080E2R150.0Z5-HXT	2	E	8,0	8	8	60	16	7,4	1,5	-	5	16,0	∞	∞	∞	∞	∞	
02968245	JH142080E2R200.0Z5-HXT	2	E	8,0	8	8	60	16	7,4	2,0	-	5	16,0	∞	∞	∞	∞	∞	
02968246	JH142080E2R300.0Z5-HXT	2	E	8,0	8	8	60	16	7,4	3,0	-	5	16,0	∞	∞	∞	∞	∞	
02968247	JH142100E2R050.0Z5-HXT	2	E	10,0	10	10	70	20	9,4	0,5	-	5	20,0	∞	∞	∞	∞	∞	
02968248	JH142100E2R100.0Z5-HXT	2	E	10,0	10	10	70	20	9,4	1,0	-	5	20,0	∞	∞	∞	∞	∞	
02968249	JH142100E2R200.0Z5-HXT	2	E	10,0	10	10	70	20	9,4	2,0	-	5	20,0	∞	∞	∞	∞	∞	
02968250	JH142100E2R250.0Z5-HXT	2	E	10,0	10	10	70	20	9,4	2,5	-	5	20,0	∞	∞	∞	∞	∞	
02968251	JH142120E2R100.0Z6-HXT	2	E	12,0	12	12	75	24	11,4	1,0	-	6	24,0	∞	∞	∞	∞	∞	
02968252	JH142120E2R200.0Z6-HXT	2	E	12,0	12	12	75	24	11,4	2,0	-	6	24,0	∞	∞	∞	∞	∞	
02968253	JH142120E2R300.0Z6-HXT	2	E	12,0	12	12	75	24	11,4	3,0	-	6	24,0	∞	∞	∞	∞	∞	
02968254	JH142120E2R400.0Z6-HXT	2	E	12,0	12	12	75	24	11,4	4,0	-	6	24,0	∞	∞	∞	∞	∞	

* The effective under-neck length for the various draft angles. Remark ∞ = infinity, no collision in projection length area.

JH142 – High speed – High precision – Torical – Hardened steel – 2-6 Flutes – Cylindrical – Corner radius



Tolerances:
 Run-out= <0,005 mm
 DMM= h5
 DC= 0-0.01 mm
 RE= ±0,005 mm
 Regrind possible if DC is ≥Ø6

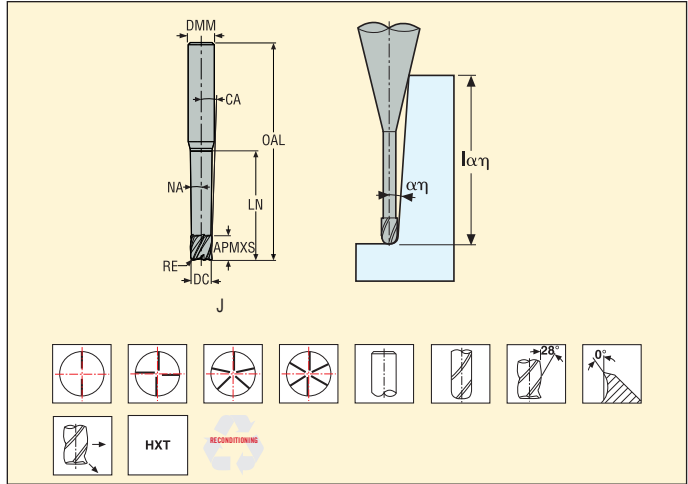

Ordering and Product No.	Designation	Length index	Tool shape	Dimensions in mm							PCEDC	Max. cut depth rel. to αη (lαη, ref)*						
				DC	DMM	APMXS	OAL	LN	DN	RE		CA	WDX0	WDX05	WDX1	WDX15	WDX2	WDX3
02968255	JH142020J3R030.0Z2-HXT	3	J	2,0	6	2	60	10	1,9	0,3	6,72	2	5,23	10,27	10,95	11,31	11,69	12,54
02968256	JH142020J3R030.0Z4-HXT	3	J	2,0	6	2	60	10	1,9	0,3	6,72	4	5,23	10,27	10,95	11,31	11,69	12,54
02968257	JH142020J3R050.0Z2-HXT	3	J	2,0	6	2	60	10	1,9	0,5	6,79	2	5,23	10,24	10,94	11,29	11,66	12,5
02968258	JH142020J3R050.0Z4-HXT	3	J	2,0	6	2	60	10	1,9	0,5	6,79	4	5,23	10,24	10,94	11,29	11,66	12,5
02970111	JH142040J3R030.0Z4-HXT	3	J	4,0	6	4	60	20	3,7	0,3	2,45	4	13,87	20,79	21,52	22,23	22,99	∞
02968259	JH142030J3R050.0Z2-HXT	3	J	3,0	6	3	60	15	2,8	0,5	4,3	2	9,57	15,58	16,22	16,75	17,32	18,57
02968260	JH142030J3R050.0Z4-HXT	3	J	3,0	6	3	60	15	2,8	0,5	4,3	4	9,57	15,58	16,22	16,75	17,32	18,57
02968261	JH142030J3R100.0Z2-HXT	3	J	3,0	6	3	60	15	2,8	1,0	4,4	2	9,57	15,54	16,19	16,7	17,25	18,46
02968262	JH142030J3R100.0Z4-HXT	3	J	3,0	6	3	60	15	2,8	1,0	4,4	4	9,57	15,54	16,19	16,7	17,25	18,46
02968263	JH142040J3R030.0Z2-HXT	3	J	4,0	6	4	60	20	3,7	0,3	2,45	2	13,87	20,79	21,52	22,23	22,99	∞
02968264	JH142040J3R050.0Z4-HXT	3	J	4,0	6	4	60	20	3,7	0,5	2,48	4	13,87	20,78	21,51	22,21	22,97	∞
02968265	JH142040J3R050.0Z2-HXT	3	J	4,0	6	4	60	20	3,7	0,5	2,48	2	13,87	20,78	21,51	22,21	22,97	∞
02968266	JH142040J3R100.0Z2-HXT	3	J	4,0	6	4	60	20	3,7	1,0	2,53	2	13,87	20,76	21,48	22,16	22,9	∞
02968267	JH142040J3R100.0Z4-HXT	3	J	4,0	6	4	60	20	3,7	1,0	2,53	4	13,87	20,76	21,48	22,16	22,9	∞
02968268	JH142060J3R050.0Z4-HXT	3	J	6,0	8	6	75	30	5,6	0,5	1,75	4	19,15	30,85	31,88	32,93	∞	∞
02968269	JH142060J3R050.0Z5-HXT	3	J	6,0	8	6	75	30	5,6	0,5	1,75	5	19,15	30,85	31,88	32,93	∞	∞
02968270	JH142060J3R100.0Z4-HXT	3	J	6,0	8	6	75	30	5,6	1,0	1,77	4	19,15	30,83	31,85	32,88	∞	∞
02968271	JH142060J3R100.0Z5-HXT	3	J	6,0	8	6	75	30	5,6	1,0	1,77	5	19,15	30,83	31,85	32,88	∞	∞
02968272	JH142060J3R150.0Z5-HXT	3	J	6,0	8	6	75	30	5,6	1,5	1,8	5	19,15	30,8	31,82	32,83	∞	∞
02968273	JH142060J3R200.0Z5-HXT	3	J	6,0	8	6	75	30	5,6	2,0	1,83	5	19,15	30,78	31,78	32,78	∞	∞
02968274	JH142080J3R050.0Z5-HXT	3	J	8,0	10	8	85	40	7,4	0,5	1,34	5	27,67	41,12	42,44	∞	∞	∞
02968275	JH142080J3R100.0Z5-HXT	3	J	8,0	10	8	85	40	7,4	1,0	1,36	5	27,67	41,11	42,41	∞	∞	∞
02968276	JH142080J3R150.0Z5-HXT	3	J	8,0	10	8	85	40	7,4	1,5	1,37	5	27,67	41,09	42,38	∞	∞	∞
02968277	JH142080J3R200.0Z5-HXT	3	J	8,0	10	8	85	40	7,4	2,0	1,39	5	27,67	41,08	42,35	∞	∞	∞
02968278	JH142100J3R050.0Z5-HXT	3	J	10,0	12	10	100	50	9,4	0,5	1,1	5	29,67	50,97	52,62	∞	∞	∞
02968279	JH142100J3R100.0Z5-HXT	3	J	10,0	12	10	100	50	9,4	1,0	1,11	5	29,67	50,95	52,59	∞	∞	∞
02968280	JH142100J3R200.0Z5-HXT	3	J	10,0	12	10	100	50	9,4	2,0	1,13	5	29,67	50,91	52,53	∞	∞	∞
02968281	JH142100J3R400.0Z5-HXT	3	J	10,0	12	10	100	50	9,4	4,0	1,17	5	29,67	50,83	52,4	∞	∞	∞
02968282	JH142020J6R030.0Z4-HXT	6	J	2,0	6	2	75	20	1,9	0,3	4,33	4	5,23	11,4	21,0	21,71	22,45	24,11
02968283	JH142020J6R050.0Z4-HXT	6	J	2,0	6	2	75	20	1,9	0,5	4,36	4	5,23	11,14	20,99	21,69	22,43	24,06
02968284	JH142030J6R050.0Z4-HXT	6	J	3,0	6	3	75	30	2,8	0,5	2,52	4	9,57	20,92	31,32	32,35	33,46	∞
02968285	JH142030J6R100.0Z4-HXT	6	J	3,0	6	3	75	30	2,8	1,0	2,56	4	9,57	20,3	31,29	32,31	33,39	∞
02968286	JH142040J6R030.0Z4-HXT	6	J	4,0	6	4	80	40	3,7	0,3	1,36	4	13,87	30,85	41,65	∞	∞	∞
02968287	JH142040J6R050.0Z4-HXT	6	J	4,0	6	4	80	40	3,7	0,5	1,37	4	13,87	30,6	41,65	∞	∞	∞
02968288	JH142040J6R100.0Z4-HXT	6	J	4,0	6	4	80	40	3,7	1,0	1,38	4	13,87	29,98	41,6	∞	∞	∞

* The effective under -neck length for the various draft angles. Remark ∞ = infinity, no collision in projection length area.

Cutting data – JH142 Copy milling roughing

SMG		a _e /DC	a _p /DC	f _z									v _c
				2	3	4	6	8	10	12	16		
P1	M/E	0,050	0,050	0,019	0,028	0,038	0,060	0,075	0,095	0,11	0,14	485 (455 – 540)	
P2	M/E	0,050	0,050	0,020	0,030	0,040	0,060	0,080	0,10	0,12	0,14	470 (440 – 520)	
P3	M/E	0,050	0,050	0,018	0,028	0,036	0,055	0,075	0,090	0,11	0,14	410 (385 – 455)	
P4	M/E	0,050	0,050	0,018	0,028	0,036	0,055	0,070	0,090	0,11	0,13	360 (340 – 400)	
P5	M/E	0,050	0,050	0,018	0,026	0,036	0,055	0,070	0,090	0,10	0,13	345 (325 – 385)	
P6	M/E	0,050	0,050	0,018	0,026	0,036	0,055	0,070	0,090	0,10	0,13	385 (365 – 430)	
P7	M/E	0,050	0,050	0,018	0,026	0,036	0,055	0,070	0,090	0,10	0,13	365 (345 – 405)	
P8	M/E	0,050	0,050	0,018	0,028	0,036	0,055	0,075	0,090	0,11	0,14	345 (325 – 385)	
P11	M/E	0,050	0,050	0,018	0,026	0,036	0,055	0,070	0,090	0,10	0,13	355 (335 – 395)	
K1	A/E	0,050	0,050	0,018	0,026	0,036	0,055	0,070	0,090	0,10	0,13	345 (325 – 385)	
K2	A/E	0,050	0,050	0,016	0,024	0,032	0,048	0,065	0,080	0,095	0,12	305 (285 – 335)	
K3	A/E	0,050	0,050	0,016	0,024	0,032	0,048	0,065	0,080	0,095	0,12	255 (240 – 285)	
K4	A/E	0,050	0,050	0,016	0,024	0,032	0,048	0,065	0,080	0,095	0,12	245 (230 – 270)	
K5	A/E	0,050	0,050	0,018	0,026	0,036	0,055	0,070	0,090	0,10	0,13	345 (325 – 385)	
K6	A/E	0,050	0,050	0,020	0,030	0,040	0,060	0,080	0,10	0,12	0,15	500 (475 – 560)	
K7	A/E	0,050	0,050	0,018	0,026	0,036	0,055	0,070	0,090	0,10	0,13	440 (415 – 490)	
H3	M/A	0,020	0,020	0,010	0,016	0,020	0,032	0,042	0,050	0,060	0,075	95 (70 – 120)	
H5	M/A	0,040	0,040	0,013	0,020	0,026	0,040	0,055	0,065	0,080	0,095	310 (280 – 335)	
H7	M/A	0,020	0,020	0,010	0,016	0,020	0,032	0,042	0,050	0,060	0,075	95 (70 – 120)	
H8	M/A	0,040	0,040	0,0090	0,014	0,018	0,028	0,036	0,046	0,055	0,070	315 (290 – 340)	
H11	M/A	0,040	0,040	0,013	0,020	0,026	0,040	0,055	0,065	0,080	0,095	390 (360 – 425)	
H12	M/A	0,050	0,050	0,0055	0,0085	0,011	0,017	0,022	0,028	0,034	0,042	355 (325 – 385)	
H21	M/A	0,040	0,040	0,0090	0,014	0,018	0,028	0,036	0,046	0,055	0,070	315 (290 – 340)	
H31	M/A	0,030	0,030	0,011	0,016	0,022	0,032	0,044	0,055	0,065	0,080	140 (120 – 170)	

For cutting data recalculations, see page 411-418.

SMG = Seco material group

Coolant = A=air D=dry E=emulsion M=mist spray

v_c = m/min

f_z = mm

a_p (mm)/DC (mm) = factor

a_e (mm)/DC (mm) = factor

All cutting data are target values

JH112 – High speed – High precision – Hardened steel – Ball nose – 2 Flutes – Cylindrical



Tolerances:
 Run-out= <0,005 mm
 DMM= h5
 DC= 0-0.01 mm
 RE= ±0,005 mm
 Regrind possible if DC is ≥Ø6

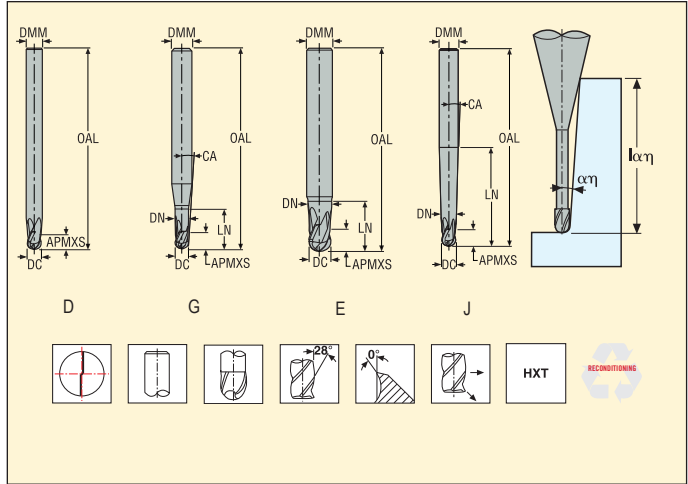

Ordering and Product No.	Designation	Length index	Tool shape	Dimensions in mm							PCEDC	Max. cut depth rel. to αη (lαη, ref)*					
				DC	DMM	APMXS	OAL	LN	DN	CA		WDK0	WDK05	WDK1	WDK15	WDK2	WDK3
02970112	JH112020G1B.02Z-HXT	1	G	2,0	4	2	40	4	1,9	6,45	2	4,66	4,84	5,03	5,24	5,47	6,03
02970113	JH112030G1B.02Z-HXT	1	G	3,0	4	3	40	6	2,8	3,3	2	6,96	7,29	7,66	8,08	8,56	9,78
02970114	JH112040D1B.02Z-HXT	1	D	4,0	4	4	40	-	-	-	2	4,0	∞	∞	∞	∞	∞
02970115	JH112050G1B.02Z-HXT	1	G	5,0	6	5	50	10	4,6	2,0	2	12,09	12,96	14,01	15,29	16,89	∞
02970116	JH112060D1B.02Z-HXT	1	D	6,0	6	6	50	-	-	-	2	6,0	∞	∞	∞	∞	∞
02970117	JH112080D1B.02Z-HXT	1	D	8,0	8	8	65	-	-	-	2	8,0	∞	∞	∞	∞	∞
02970118	JH112100D1B.02Z-HXT	1	D	10,0	10	10	65	-	-	-	2	10,0	∞	∞	∞	∞	∞
02970119	JH112020G2B.02Z-HXT	2	G	2,0	3	2	50	10	1,9	2,5	2	10,79	11,1	11,42	11,77	∞	∞
02970120	JH112030D2B.02Z-HXT	2	D	3,0	3	3	50	-	-	-	2	∞	∞	∞	∞	∞	∞
02970121	JH112040D2B.02Z-HXT	2	D	4,0	4	4	60	-	-	-	2	4,0	∞	∞	∞	∞	∞
02970122	JH112050D2B.02Z-HXT	2	D	5,0	5	5	60	-	-	-	2	5,0	∞	∞	∞	∞	∞
02970123	JH112060D2B.02Z-HXT	2	D	6,0	6	6	75	-	-	-	2	6,0	∞	∞	∞	∞	∞
02970124	JH112020G3B.02Z-HXT	3	G	2,0	6	2	60	4	1,9	8,12	2	4,66	4,84	5,03	5,24	5,47	6,03
02970125	JH112025G3B.02Z-HXT	3	G	2,5	6	3	60	5	2,4	7,39	2	5,66	5,87	6,1	6,36	6,64	7,31
02970126	JH112030G3B.02Z-HXT	3	G	3,0	6	3	60	6	2,8	5,5	2	6,97	7,31	7,7	8,14	8,65	9,95
02968289	JH112035G3B.02Z-HXT	3	G	3,5	6	4	65	7	3,2	3,81	2	8,62	9,24	9,99	10,9	12,05	15,49
02970127	JH112040G3B.02Z-HXT	3	G	4,0	6	4	65	8	3,7	3,34	2	9,62	10,31	11,14	12,15	13,42	17,25
02970128	JH112050G3B.02Z-HXT	3	G	5,0	6	5	65	10	4,6	2,0	2	12,09	12,96	14,01	15,29	16,89	∞
02970129	JH112060G3B.02Z-HXT	3	G	6,0	8	6	75	12	5,6	2,78	2	14,09	15,1	16,31	17,79	19,64	25,2
02968290	JH112080E3B.02Z-HXT	3	E	8,0	8	8	75	16	7,4	-	2	16,0	∞	∞	∞	∞	∞
02968291	JH112100E3B.02Z-HXT	3	E	10,0	10	10	80	20	9,4	-	2	20,0	∞	∞	∞	∞	∞
02968292	JH112120E3B.02Z-HXT	3	E	12,0	12	12	90	24	11,4	-	2	24,0	∞	∞	∞	∞	∞
02970130	JH112020G4B.02Z-HXT	4	G	2,0	6	2	80	20	1,9	3,82	2	20,66	21,59	22,61	23,73	24,98	27,94
02970131	JH112030G4B.02Z-HXT	4	G	3,0	6	3	80	20	2,8	2,91	2	20,97	22,18	23,55	25,11	26,92	31,51
02970132	JH112040G4B.02Z-HXT	4	G	4,0	6	4	80	20	3,7	1,97	2	21,62	23,39	25,53	28,13	∞	∞
02970133	JH112050G4B.02Z-HXT	4	G	5,0	6	5	100	50	4,6	0,53	2	52,09	56,58	∞	∞	∞	∞
02968293	JH112060D4B.02Z-HXT	4	D	6,0	6	6	100	-	5,6	-	2	6,0	∞	∞	∞	∞	∞
02968294	JH112080D4B.02Z-HXT	4	D	8,0	8	8	110	-	7,4	-	2	8,0	∞	∞	∞	∞	∞
02968295	JH112100D4B.02Z-HXT	4	D	10,0	10	10	125	-	9,4	-	2	10,0	∞	∞	∞	∞	∞
02968296	JH112120D4B.02Z-HXT	4	D	12,0	12	12	125	-	11,4	-	2	12,0	∞	∞	∞	∞	∞
02970134	JH112020J5B.02Z-HXT	5	J	2,0	6	2	80	-	1,9	3,3	2	3,09	3,43	3,91	4,63	5,81	14,63
02970135	JH112030J5B.02Z-HXT	5	J	3,0	6	3	80	-	2,8	2,2	2	5,7	6,75	8,51	12,03	22,61	∞
02970136	JH112040J5B.02Z-HXT	5	J	4,0	6	4	80	-	3,7	1,2	2	10,58	15,35	32,07	∞	∞	∞
02970137	JH112050J5B.02Z-HXT	5	J	5,0	8	5	100	-	4,6	1,6	2	11,47	14,56	20,93	41,46	∞	∞
02970138	JH112060J5B.02Z-HXT	5	J	6,0	8	6	100	-	5,6	1,1	2	14,72	21,24	44,08	∞	∞	∞
02970139	JH112080J5B.02Z-HXT	5	J	8,0	10	8	125	-	7,4	1,0	2	20,71	29,7	59,65	∞	∞	∞

* The effective under-neck length for the various draft angles. Remark ∞ = infinity, no collision in projection length area.

Cutting data – JH112 Copy milling finishing

SMG		a _p /DC	f _z											v _c
			2	2,5	3	3,5	4	5	6	8	10	12		
K1	E	0,30	0,030	0,038	0,044	0,050	0,060	0,075	0,090	0,12	0,15	0,18	520 (490 – 740)	
K2	E	0,30	0,030	0,038	0,044	0,050	0,060	0,075	0,090	0,12	0,15	0,18	445 (425 – 640)	
K3	E	0,30	0,030	0,038	0,044	0,050	0,060	0,075	0,090	0,12	0,15	0,18	380 (360 – 540)	
K4	E	0,30	0,030	0,038	0,044	0,050	0,060	0,075	0,090	0,12	0,15	0,18	360 (345 – 520)	
K5	E	0,30	0,030	0,036	0,044	0,050	0,060	0,075	0,090	0,12	0,15	0,17	415 (370 – 610)	
K6	E	0,30	0,030	0,038	0,044	0,050	0,060	0,075	0,090	0,12	0,15	0,18	610 (540 – 910)	
K7	E	0,30	0,030	0,038	0,044	0,050	0,060	0,075	0,090	0,12	0,15	0,18	680 (560 – 800)	
H3	M	0,16	0,028	0,036	0,042	0,048	0,055	0,070	0,085	0,11	0,14	0,17	155 (140 – 235)	
H5	M	0,30	0,030	0,038	0,044	0,050	0,060	0,075	0,090	0,12	0,15	0,18	285 (235 – 335)	
H7	M	0,16	0,028	0,036	0,042	0,048	0,055	0,070	0,085	0,11	0,14	0,17	155 (140 – 235)	
H8	M	0,30	0,028	0,034	0,042	0,048	0,055	0,070	0,085	0,11	0,14	0,17	285 (235 – 335)	
H11	M	0,30	0,030	0,038	0,044	0,050	0,060	0,075	0,090	0,12	0,15	0,18	360 (295 – 425)	
H12	M	0,30	0,028	0,034	0,042	0,048	0,055	0,070	0,085	0,11	0,14	0,17	330 (275 – 390)	
H21	M	0,30	0,028	0,034	0,042	0,048	0,055	0,070	0,085	0,11	0,14	0,17	285 (235 – 335)	
H31	M	0,30	0,026	0,032	0,040	0,046	0,050	0,065	0,080	0,10	0,13	0,16	300 (290 – 435)	

Cutting data – JH112 Copy milling roughing

SMG		a _p /DC	a _p /DC	f _z											v _c
				2	2,5	3	3,5	4	5	6	8	10	12		
K1	E	0,25	0,14	0,030	0,038	0,044	0,050	0,060	0,075	0,090	0,12	0,15	0,18	315 (300 – 450)	
K2	E	0,25	0,14	0,030	0,036	0,044	0,050	0,060	0,075	0,090	0,12	0,15	0,17	275 (260 – 390)	
K3	E	0,25	0,14	0,030	0,036	0,044	0,050	0,060	0,075	0,090	0,12	0,15	0,17	235 (220 – 330)	
K4	E	0,25	0,14	0,030	0,036	0,044	0,050	0,060	0,075	0,090	0,12	0,15	0,17	220 (210 – 315)	
K5	E	0,16	0,14	0,028	0,036	0,042	0,050	0,055	0,070	0,085	0,11	0,14	0,17	285 (255 – 425)	
K6	E	0,16	0,14	0,030	0,038	0,044	0,050	0,060	0,075	0,090	0,12	0,15	0,18	415 (370 – 620)	
K7	E	0,25	0,12	0,030	0,038	0,044	0,050	0,060	0,075	0,090	0,12	0,15	0,18	420 (345 – 490)	
H3	M	0,12	0,040	0,028	0,036	0,042	0,048	0,055	0,070	0,085	0,11	0,14	0,17	110 (100 – 165)	
H5	M	0,25	0,095	0,030	0,038	0,044	0,050	0,060	0,075	0,090	0,12	0,15	0,18	175 (145 – 205)	
H7	M	0,12	0,034	0,028	0,036	0,042	0,048	0,055	0,070	0,085	0,11	0,14	0,17	110 (100 – 165)	
H8	M	0,25	0,080	0,028	0,034	0,042	0,048	0,055	0,070	0,085	0,11	0,14	0,17	180 (145 – 210)	
H11	M	0,25	0,095	0,030	0,038	0,044	0,050	0,060	0,075	0,090	0,12	0,15	0,18	225 (185 – 265)	
H12	M	0,25	0,080	0,028	0,034	0,042	0,048	0,055	0,070	0,085	0,11	0,14	0,17	210 (170 – 245)	
H21	M	0,25	0,080	0,028	0,034	0,042	0,048	0,055	0,070	0,085	0,11	0,14	0,17	180 (145 – 210)	
H31	M	0,20	0,095	0,026	0,032	0,040	0,046	0,050	0,065	0,080	0,10	0,13	0,16	200 (190 – 285)	

For cutting data recalculations, see page 411-418.

SMG = Seco material group

Coolant = A=air D=dry E=emulsion M=mist spray

v_c = m/min

f_z = mm

a_p (mm)/DC (mm) = factor

a_s (mm)/DC (mm) = factor

All cutting data are target values

Cutting data – JH150 Copy milling roughing

SMG		a_e/DC	a_p/DC	f_z					v_c
				6	8	10	12		
K1	A	0,30	0,14	0,10	0,14	0,17	0,20	290 (310 – 375)	
K2	A	0,30	0,14	0,10	0,14	0,17	0,20	250 (265 – 325)	
K3	A	0,30	0,14	0,10	0,14	0,17	0,20	210 (225 – 275)	
K5	A	0,20	0,14	0,10	0,14	0,17	0,20	255 (265 – 340)	
K6	A	0,20	0,14	0,10	0,14	0,17	0,20	375 (390 – 500)	
K7	A	0,20	0,14	0,10	0,14	0,17	0,20	325 (340 – 435)	
H3	M	0,050	0,020	0,085	0,11	0,14	0,17	85 (90 – 125)	
H5	M	0,20	0,060	0,10	0,14	0,17	0,20	180 (160 – 200)	
H7	M	0,050	0,017	0,085	0,11	0,14	0,17	85 (85 – 120)	
H8	M	0,20	0,050	0,095	0,12	0,16	0,19	180 (160 – 205)	
H11	M	0,20	0,060	0,10	0,14	0,17	0,20	230 (205 – 255)	
H12	M	0,20	0,050	0,095	0,12	0,16	0,19	210 (185 – 235)	
H21	M	0,20	0,050	0,095	0,12	0,16	0,19	180 (160 – 205)	
H31	M	0,15	0,060	0,090	0,12	0,15	0,18	125 (120 – 185)	

For cutting data recalculations, see page 411-418.

SMG = Seco material group

Coolant = A=air D=dry E=emulsion M=mist spray

v_c = m/min

f_z = mm

a_p (mm)/DC (mm)= factor

a_e (mm)/DC (mm)= factor

All cutting data are target values

Cutting data – JH160 Copy milling finishing

SMG		a _e /DC	a _p /DC	f _z							v _c
				4	5	6	8	10	12		
P1	M/E/A	0,020	0,022	0,070	0,085	0,10	0,14	0,17	0,20	540 (445 — 710)	
P2	M/E/A	0,020	0,022	0,070	0,085	0,10	0,14	0,17	0,20	530 (435 — 690)	
P3	M/E/A	0,020	0,022	0,070	0,085	0,10	0,14	0,17	0,20	455 (375 — 590)	
P4	M/E/A	0,020	0,022	0,070	0,085	0,10	0,14	0,17	0,20	400 (330 — 520)	
P5	M/E/A	0,020	0,022	0,070	0,085	0,10	0,14	0,17	0,20	385 (315 — 495)	
P6	M/E/A	0,020	0,022	0,070	0,085	0,10	0,14	0,17	0,20	430 (355 — 560)	
P7	M/E/A	0,020	0,022	0,070	0,085	0,10	0,14	0,17	0,20	405 (335 — 530)	
P8	M/E/A	0,020	0,022	0,070	0,085	0,10	0,14	0,17	0,20	385 (315 — 495)	
P11	M/E/A	0,020	0,022	0,070	0,085	0,10	0,14	0,17	0,20	395 (325 — 510)	
P12	M/E/A	0,020	0,022	0,060	0,075	0,090	0,12	0,15	0,18	235 (195 — 305)	
H3	M/E/A	0,010	0,0075	0,050	0,065	0,080	0,10	0,13	0,16	85 (90 — 115)	
H5	M/E/A	0,010	0,015	0,050	0,065	0,080	0,10	0,13	0,16	335 (315 — 360)	
H7	M/E/A	0,010	0,0075	0,050	0,065	0,080	0,10	0,13	0,16	85 (90 — 115)	
H8	M/E/A	0,010	0,015	0,050	0,065	0,080	0,10	0,13	0,16	335 (315 — 360)	
H11	M/E/A	0,010	0,015	0,050	0,065	0,080	0,10	0,13	0,16	430 (400 — 460)	
H12	M/E/A	0,020	0,022	0,046	0,055	0,070	0,090	0,11	0,14	365 (340 — 390)	
H21	M/E/A	0,010	0,015	0,050	0,065	0,080	0,10	0,13	0,16	335 (315 — 360)	
H31	M/E/A	0,010	0,015	0,050	0,065	0,080	0,10	0,13	0,16	165 (175 — 215)	

For cutting data recalculations, see page 411-418.

SMG = Seco material group

Coolant = A=air D=dry E=emulsion M=mist spray

v_c = m/min

f_z = mm

a_p (mm)/DC (mm)= factor

a_e (mm)/DC (mm)= factor

All cutting data are target values



JME142 - Miniature - Hardened steel - Square - 2 Flutes - Cylindrical - Corner radius



Tolerances:

Run-out= <0,005 mm

DMM = h5

DC <0,6 = 0-0,008 mm DC >0,6 = 0-0,01 mm

RE = ±0,005 mm

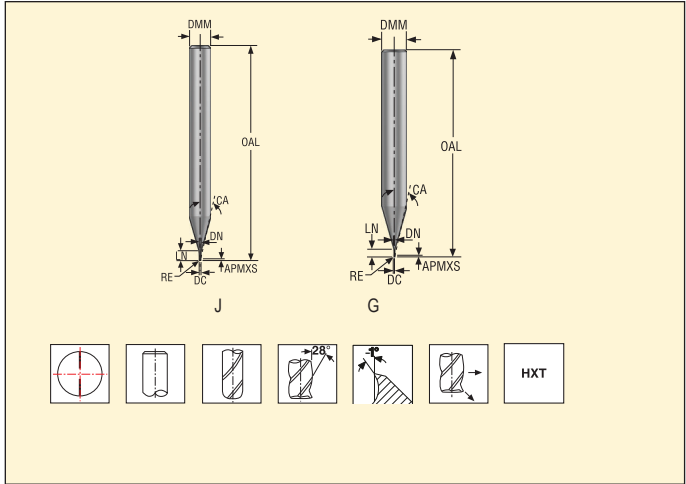

Ordering and Product No.	Designation	Length index	Tool shape	Dimensions in mm							RE	CA	NA	PCEDC	Max. cut depth rel. to α_{11} (to α_{11} , ref)*					
				DC	DMM	APMXS	OAL	LN	DN	WDX0					WDX05	WDX1	WDX15	WDX2	WDX3	
03205080	JME142002G1R005Z2.0-HXT	1	G	0,2	4	0,15	40	0,4	0,18	0,05	15,12	0,0	2	0,48	0,5	0,51	0,53	0,55	0,58	
03205082	JME142003G1R005Z2.0-HXT	1	G	0,3	4	0,225	40	0,6	0,28	0,05	14,77	0,0	2	0,68	0,7	0,73	0,75	0,77	0,81	
03205084	JME142004G1R005Z2.0-HXT	1	G	0,4	4	0,3	40	0,8	0,37	0,05	14,39	0,0	2	0,9	0,93	0,95	0,98	1,01	1,07	
03205086	JME142005G1R005Z2.0-HXT	1	G	0,5	4	0,375	40	0,75	0,46	0,05	14,01	0,0	2	1,13	1,15	1,18	1,21	1,25	1,32	
03205099	JME142006G1R005Z2.0-HXT	1	G	0,6	4	0,45	40	0,9	0,56	0,05	13,67	0,0	2	1,32	1,35	1,39	1,43	1,47	1,55	
03205121	JME142008G1R005Z2.0-HXT	1	G	0,8	6	0,6	50	1,2	0,76	0,05	13,98	0,0	2	1,72	1,76	1,81	1,86	1,91	2,02	
03205139	JME142010G1R005Z2.0-HXT	1	G	1,0	6	0,75	50	1,5	0,95	0,05	13,49	0,0	2	2,14	2,19	2,25	2,31	2,37	2,51	
03205151	JME142012G1R005Z2.0-HXT	1	G	1,2	6	0,9	50	1,8	1,15	0,05	13,02	0,0	2	2,54	2,6	2,67	2,74	2,81	2,98	
03205161	JME142015G1R005Z2.0-HXT	1	G	1,5	6	1,125	50	2,25	1,45	0,05	12,3	0,0	2	3,14	3,22	3,3	3,38	3,47	3,68	
03205081	JME142002J2R005Z2.0-HXT	2	J	0,2	4	0,15	40	0,6	0,18	0,05	14,23	0,9	2	0,54	0,72	0,81	0,89	0,95	1,07	
03205083	JME142003J2R005Z2.0-HXT	2	J	0,3	4	0,225	40	0,9	0,28	0,05	13,67	0,9	2	0,61	1,0	1,13	1,23	1,31	1,44	
03205085	JME142004J2R005Z2.0-HXT	2	J	0,4	4	0,3	40	1,2	0,37	0,05	13,1	0,9	2	1,01	1,37	1,5	1,59	1,68	1,83	
03205087	JME142005J2R005Z2.0-HXT	2	J	0,5	4	0,375	40	1,5	0,46	0,05	12,54	0,9	2	1,41	1,72	1,85	1,95	2,04	2,2	
03205093	JME142005J2R010Z2.0-HXT	2	J	0,5	4	0,375	40	1,5	0,46	0,1	12,61	0,9	2	1,41	1,72	1,84	1,95	2,03	2,19	
03205100	JME142006J2R005Z2.0-HXT	2	J	0,6	4	0,45	40	2,0	0,56	0,05	11,76	0,9	2	1,42	2,18	2,36	2,48	2,59	2,78	
03205107	JME142006J2R010Z2.0-HXT	2	J	0,6	4	0,45	40	2,0	0,56	0,1	11,83	0,9	2	1,42	2,18	2,35	2,48	2,58	2,77	
03205122	JME142008J2R005Z2.0-HXT	2	J	0,8	4	0,6	40	2,5	0,76	0,05	10,92	0,9	2	1,56	2,67	2,88	3,02	3,14	3,37	
03205129	JME142008J2R010Z2.0-HXT	2	J	0,8	4	0,6	40	2,5	0,76	0,1	10,98	0,9	2	1,57	2,66	2,87	3,01	3,13	3,36	
03205135	JME142008J2R020Z2.0-HXT	2	J	0,8	4	0,6	40	2,5	0,76	0,2	11,1	0,9	2	1,57	2,65	2,86	3,0	3,12	3,34	
03205088	JME142005G2R005Z2.0-HXT	2	G	0,5	6	0,375	50	1,5	0,46	0,05	13,5	0,0	2	1,78	1,9	2,0	2,09	2,16	2,32	
03205094	JME142005G2R010Z2.0-HXT	2	G	0,5	6	0,375	50	1,5	0,46	0,1	13,55	0,0	2	1,78	1,9	1,99	2,08	2,16	2,31	
03205101	JME142006G2R005Z2.0-HXT	2	G	0,6	6	0,45	50	2,0	0,56	0,05	9,48	0,0	2	2,27	2,42	2,54	2,67	2,82	3,16	
03205108	JME142006G2R010Z2.0-HXT	2	G	0,6	6	0,45	50	2,0	0,56	0,1	9,51	0,0	2	2,27	2,42	2,54	2,66	2,81	3,14	
03205123	JME142008G2R005Z2.0-HXT	2	G	0,8	6	0,6	50	2,5	0,76	0,05	9,15	0,0	2	2,77	2,95	3,09	3,25	3,43	3,84	
03205130	JME142008G2R010Z2.0-HXT	2	G	0,8	6	0,6	50	2,5	0,76	0,1	9,17	0,0	2	2,77	2,94	3,09	3,24	3,41	3,82	
03205136	JME142008G2R020Z2.0-HXT	2	G	0,8	6	0,6	50	2,5	0,76	0,2	9,22	0,0	2	2,77	2,94	3,08	3,23	3,39	3,79	
03205140	JME142010G2R005Z2.0-HXT	2	G	1,0	6	0,75	50	4,0	0,95	0,05	8,29	0,0	2	4,32	4,55	4,77	5,01	5,29	5,93	
03205145	JME142010G2R010Z2.0-HXT	2	G	1,0	6	0,75	50	4,0	0,95	0,1	8,31	0,0	2	4,32	4,54	4,76	5,01	5,27	5,91	
03205148	JME142010G2R020Z2.0-HXT	2	G	1,0	6	0,75	50	4,0	0,95	0,2	8,36	0,0	2	4,32	4,54	4,75	4,99	5,25	5,88	
03205152	JME142012G2R005Z2.0-HXT	2	G	1,2	6	0,9	50	4,5	1,15	0,05	7,97	0,0	2	4,82	5,07	5,32	5,59	5,89	6,62	
03205155	JME142012G2R010Z2.0-HXT	2	G	1,2	6	0,9	50	4,5	1,15	0,1	7,99	0,0	2	4,82	5,07	5,31	5,58	5,88	6,6	
03205158	JME142012G2R020Z2.0-HXT	2	G	1,2	6	0,9	50	4,5	1,15	0,2	8,04	0,0	2	4,82	5,06	5,3	5,57	5,86	6,56	
03205162	JME142015G2R005Z2.0-HXT	2	G	1,5	6	1,125	50	5,0	1,45	0,05	7,6	0,0	2	5,32	5,59	5,87	6,17	6,5	7,3	
03205167	JME142015G2R010Z2.0-HXT	2	G	1,5	6	1,125	50	5,0	1,45	0,1	9,7	0,0	2	5,32	5,58	5,77	5,96	6,16	6,61	
03205171	JME142015G2R020Z2.0-HXT	2	G	1,5	6	1,125	50	5,0	1,45	0,2	9,76	0,0	2	5,32	5,57	5,76	5,95	6,15	6,59	

JME142 - Miniature - Hardened steel - Square - 2 Flutes - Cylindrical - Corner radius



Tolerances:

Run-out= <0,005 mm

DMM = h5

DC <0,6 = 0-0,008 mm DC >0,6 = 0-0,01 mm

RE = ±0,005 mm

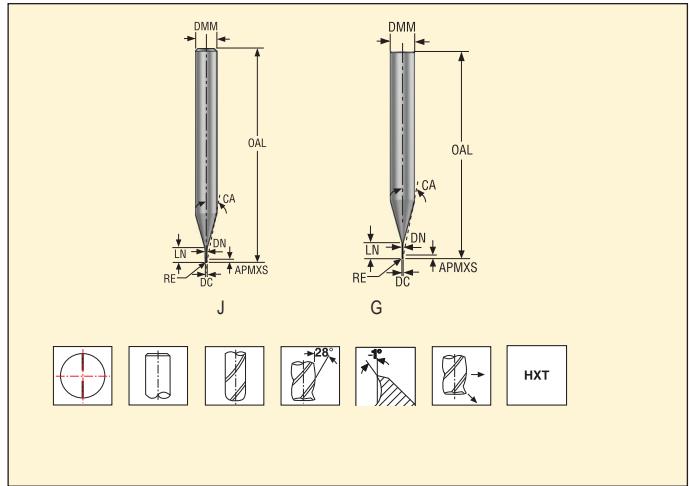

Ordering and Product No.	Designation	Length index	Tool shape	Dimensions in mm							RE	CA	NA	PCEDC	Max. cut depth rel. to α_{11} (k ₂₁ , ref)*					
				DC	DMM	APMXS	OAL	LN	DN	WDX0					WDX05	WDX1	WDX15	WDX2	WDX3	
03205174	JME142018G2R005Z2.0-HXT	2	G	1,8	6	1,35	50	5,0	1,75	0,05	9,4	0,0	2	5,32	5,58	5,77	5,96	6,17	6,62	
03205177	JME142018G2R010Z2.0-HXT	2	G	1,8	6	1,35	50	5,0	1,75	0,1	9,43	0,0	2	5,32	5,58	5,77	5,96	6,16	6,61	
03205180	JME142020G2R005Z2.0-HXT	2	G	2,0	6	1,5	50	6,0	1,94	0,05	8,52	0,0	2	6,35	6,64	6,85	7,08	7,33	7,87	
03205185	JME142020G2R010Z2.0-HXT	2	G	2,0	6	1,5	50	6,0	1,94	0,1	8,55	0,0	2	6,35	6,64	6,85	7,08	7,32	7,86	
03205188	JME142020G2R020Z2.0-HXT	2	G	2,0	6	1,5	50	6,0	1,94	0,2	8,6	0,0	2	6,35	6,63	6,84	7,07	7,3	7,84	
03205191	JME142020G2R030Z2.0-HXT	2	G	2,0	6	1,5	50	6,0	1,94	0,3	8,66	0,0	2	6,35	6,63	6,84	7,06	7,29	7,81	
03205192	JME142025G2R005Z2.0-HXT	2	G	2,5	6	1,875	50	7,5	2,4	0,05	7,1	0,0	2	7,97	8,26	8,52	8,81	9,11	9,79	
03205195	JME142025G2R010Z2.0-HXT	2	G	2,5	6	1,875	50	7,5	2,4	0,1	7,13	0,0	2	7,97	8,26	8,52	8,8	9,11	9,78	
03205198	JME142025G2R020Z2.0-HXT	2	G	2,5	6	1,875	50	7,5	2,4	0,2	7,17	0,0	2	7,97	8,25	8,51	8,79	9,09	9,76	
03205201	JME142030G2R005Z2.0-HXT	2	G	3,0	6	2,25	50	9,0	2,85	0,05	5,81	0,0	2	9,59	9,9	10,21	10,56	10,92	11,73	
03205205	JME142030G2R010Z2.0-HXT	2	G	3,0	6	2,25	50	9,0	2,85	0,1	5,82	0,0	2	9,59	9,89	10,21	10,55	10,91	11,72	
03205208	JME142030G2R020Z2.0-HXT	2	G	3,0	6	2,25	50	9,0	2,85	0,2	5,86	0,0	2	9,59	9,89	10,2	10,54	10,9	11,7	
03205211	JME142030G2R030Z2.0-HXT	2	G	3,0	6	2,25	50	9,0	2,85	0,3	5,9	0,0	2	9,59	9,89	10,2	10,53	10,89	11,68	
03205089	JME142005J3R005Z2.0-HXT	3	J	0,5	4	0,375	40	2,5	0,46	0,05	11,24	0,9	2	1,41	2,63	2,86	3,01	3,13	3,36	
03205095	JME142005J3R010Z2.0-HXT	3	J	0,5	4	0,375	40	2,5	0,46	0,1	11,29	0,9	2	1,41	2,62	2,86	3,0	3,12	3,35	
03205103	JME142006J3R005Z2.0-HXT	3	J	0,6	4	0,45	40	3,0	0,56	0,05	10,58	0,9	2	1,42	3,05	3,37	3,54	3,67	3,94	
03205109	JME142006J3R010Z2.0-HXT	3	J	0,6	4	0,45	40	3,0	0,56	0,1	10,63	0,9	2	1,42	3,04	3,36	3,53	3,66	3,93	
03205124	JME142008J3R005Z2.0-HXT	3	J	0,8	4	0,6	40	4,0	0,76	0,05	9,36	0,9	2	1,56	3,46	4,39	4,59	4,75	5,1	
03205131	JME142008J3R010Z2.0-HXT	3	J	0,8	4	0,6	40	4,0	0,76	0,1	9,4	0,9	2	1,57	3,4	4,39	4,59	4,75	5,09	
03205090	JME142005G3R005Z2.0-HXT	3	G	0,5	6	0,375	50	3,5	0,46	0,05	11,55	0,0	2	3,78	4,0	4,16	4,3	4,44	4,77	
03205096	JME142005G3R010Z2.0-HXT	3	G	0,5	6	0,375	50	3,5	0,46	0,1	11,59	0,0	2	3,78	4,0	4,15	4,29	4,44	4,76	
03205104	JME142006G3R005Z2.0-HXT	3	G	0,6	6	0,45	50	4,0	0,56	0,05	8,46	0,0	2	4,27	4,52	4,74	4,98	5,25	5,9	
03205110	JME142006G3R010Z2.0-HXT	3	G	0,6	6	0,45	50	4,0	0,56	0,1	8,48	0,0	2	4,27	4,52	4,73	4,98	5,24	5,88	
03205126	JME142008G3R005Z2.0-HXT	3	G	0,8	6	0,6	50	5,5	0,76	0,05	9,89	0,0	2	5,77	6,08	6,28	6,49	6,72	7,21	
03205132	JME142008G3R010Z2.0-HXT	3	G	0,8	6	0,6	50	5,5	0,76	0,1	9,92	0,0	2	5,77	6,08	6,28	6,49	6,71	7,2	
03205137	JME142008G3R020Z2.0-HXT	3	G	0,8	6	0,6	50	5,5	0,76	0,2	9,98	0,0	2	5,77	6,07	6,27	6,48	6,7	7,18	
03205141	JME142010G3R005Z2.0-HXT	3	G	1,0	6	0,75	50	7,0	0,95	0,05	8,84	0,0	2	7,32	7,65	7,9	8,16	8,44	9,07	
03205146	JME142010G3R010Z2.0-HXT	3	G	1,0	6	0,75	50	7,0	0,95	0,1	8,86	0,0	2	7,32	7,65	7,9	8,16	8,44	9,06	
03205149	JME142010G3R020Z2.0-HXT	3	G	1,0	6	0,75	50	7,0	0,95	0,2	8,91	0,0	2	7,32	7,65	7,89	8,15	8,42	9,04	
03205153	JME142012G3R005Z2.0-HXT	3	G	1,2	6	0,9	50	8,0	1,15	0,05	8,16	0,0	2	8,32	8,68	8,96	9,26	9,58	10,29	
03205156	JME142012G3R010Z2.0-HXT	3	G	1,2	6	0,9	50	8,0	1,15	0,1	8,19	0,0	2	8,32	8,68	8,96	9,26	9,58	10,28	
03205159	JME142012G3R020Z2.0-HXT	3	G	1,2	6	0,9	50	8,0	1,15	0,2	8,23	0,0	2	8,32	8,68	8,95	9,25	9,56	10,26	
03205163	JME142015G3R005Z2.0-HXT	3	G	1,5	6	1,125	50	10,0	1,45	0,05	7,05	0,0	2	10,32	10,75	11,09	11,46	11,86	12,74	
03205169	JME142015G3R010Z2.0-HXT	3	G	1,5	6	1,125	50	10,0	1,45	0,1	7,06	0,0	2	10,32	10,75	11,09	11,46	11,85	12,73	
03205172	JME142015G3R020Z2.0-HXT	3	G	1,5	6	1,125	50	10,0	1,45	0,2	7,1	0,0	2	10,32	10,74	11,08	11,45	11,84	12,71	

JME142 - Miniature - Hardened steel - Square - 2 Flutes - Cylindrical - Corner radius



Tolerances:

Run-out < 0,005 mm

DMM = h5

DC < 0,6 = 0-0,008 mm DC > 0,6 = 0-0,01 mm

RE = ± 0,005 mm

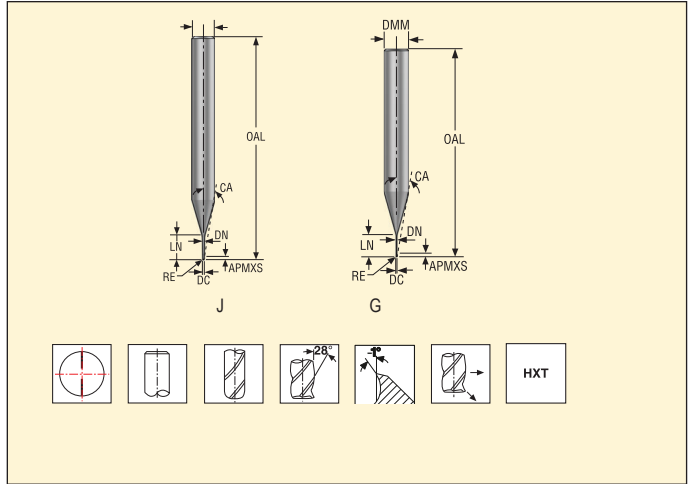

Ordering and Product No.	Designation	Length index	Tool shape	Dimensions in mm							RE	CA	NA	PCE/DC	Max. cut depth rel. to α_1 [K α_1 , ref]*					
				DC	DMM	APMXS	OAL	LN	DN	WDK0					WDK05	WDK1	WDK15	WDK2	WDK3	
03205175	JME142018G3R005Z2.0-HXT	3	G	1,8	6	1,35	50	10,0	1,75	0,05	6,77	0,0	2	10,32	10,75	11,09	11,46	11,86	12,74	
03205178	JME142018G3R010Z2.0-HXT	3	G	1,8	6	1,35	50	10,0	1,75	0,1	6,79	0,0	2	10,32	10,75	11,09	11,46	11,85	12,73	
03205181	JME142020G3R005Z2.0-HXT	3	G	2,0	6	1,5	50	12,0	1,94	0,05	5,9	0,0	2	12,35	12,83	13,24	13,68	14,16	15,21	
03205186	JME142020G3R010Z2.0-HXT	3	G	2,0	6	1,5	50	12,0	1,94	0,1	5,92	0,0	2	12,35	12,83	13,24	13,68	14,15	15,2	
03205189	JME142020G3R020Z2.0-HXT	3	G	2,0	6	1,5	50	12,0	1,94	0,2	5,95	0,0	2	12,35	12,82	13,23	13,67	14,14	15,18	
03205193	JME142025G3R005Z2.0-HXT	3	G	2,5	6	1,875	50	12,5	2,4	0,05	5,25	0,0	2	12,97	13,42	13,85	14,31	14,81	15,91	
03205196	JME142025G3R010Z2.0-HXT	3	G	2,5	6	1,875	50	12,5	2,4	0,1	5,27	0,0	2	12,97	13,41	13,85	14,31	14,8	15,9	
03205199	JME142025G3R020Z2.0-HXT	3	G	2,5	6	1,875	50	12,5	2,4	0,2	5,29	0,0	2	12,97	13,41	13,84	14,3	14,79	15,88	
03205202	JME142030G3R005Z2.0-HXT	3	G	3,0	6	2,25	60	15,0	2,85	0,05	4,14	0,0	2	15,59	16,08	16,6	17,16	17,75	19,07	
03205206	JME142030G3R010Z2.0-HXT	3	G	3,0	6	2,25	60	15,0	2,85	0,1	4,15	0,0	2	15,59	16,08	16,6	17,15	17,75	19,06	
03205209	JME142030G3R020Z2.0-HXT	3	G	3,0	6	2,25	60	15,0	2,85	0,2	4,17	0,0	2	15,59	16,08	16,59	17,14	17,73	19,04	
03205212	JME142030G3R030Z2.0-HXT	3	G	3,0	6	2,25	60	15,0	2,85	0,3	4,19	0,0	2	15,59	16,08	16,59	17,13	17,72	19,02	
03205091	JME142005J4R005Z2.0-HXT	4	J	0,5	4	0,375	40	4,0	0,46	0,05	9,71	0,9	2	1,41	3,12	4,38	4,58	4,74	5,09	
03205097	JME142005J4R010Z2.0-HXT	4	J	0,5	4	0,375	40	4,0	0,46	0,1	9,76	0,9	2	1,41	3,06	4,37	4,58	4,74	5,08	
03205105	JME142006J4R005Z2.0-HXT	4	J	0,6	4	0,45	40	5,0	0,56	0,05	8,79	0,9	2	1,42	3,13	5,39	5,63	5,82	6,26	
03205118	JME142006J4R010Z2.0-HXT	4	J	0,6	4	0,45	40	5,0	0,56	0,1	8,83	0,9	2	1,42	3,08	5,39	5,62	5,81	6,24	
03205127	JME142008J4R005Z2.0-HXT	4	J	0,8	4	0,6	40	7,0	0,76	0,05	7,28	0,9	2	1,56	3,46	7,43	7,72	7,98	8,57	
03205133	JME142008J4R010Z2.0-HXT	4	J	0,8	4	0,6	40	7,0	0,76	0,1	7,3	0,9	2	1,57	3,4	7,42	7,71	7,98	8,56	
03205092	JME142005G4R005Z2.0-HXT	4	G	0,5	6	0,375	50	5,0	0,46	0,05	10,42	0,0	2	5,28	5,56	5,75	5,95	6,15	6,61	
03205098	JME142005G4R010Z2.0-HXT	4	G	0,5	6	0,375	50	5,0	0,46	0,1	10,45	0,0	2	5,28	5,56	5,75	5,94	6,14	6,6	
03205106	JME142006G4R005Z2.0-HXT	4	G	0,6	6	0,45	50	6,0	0,56	0,05	9,72	0,0	2	6,27	6,6	6,82	7,04	7,29	7,83	
03205120	JME142006G4R010Z2.0-HXT	4	G	0,6	6	0,45	50	6,0	0,56	0,1	9,75	0,0	2	6,27	6,59	6,81	7,04	7,28	7,82	
03205128	JME142008G4R005Z2.0-HXT	4	G	0,8	6	0,6	50	8,0	0,76	0,05	8,49	0,0	2	8,27	8,67	8,95	9,24	9,56	10,27	
03205134	JME142008G4R010Z2.0-HXT	4	G	0,8	6	0,6	50	8,0	0,76	0,1	8,51	0,0	2	8,27	8,66	8,94	9,24	9,56	10,26	
03205138	JME142008G4R020Z2.0-HXT	4	G	0,8	6	0,6	50	8,0	0,76	0,2	8,56	0,0	2	8,27	8,66	8,94	9,23	9,54	10,24	
03205142	JME142010G4R005Z2.0-HXT	4	G	1,0	6	0,75	50	10,0	0,95	0,05	7,47	0,0	2	10,32	10,75	11,09	11,46	11,86	12,74	
03205147	JME142010G4R010Z2.0-HXT	4	G	1,0	6	0,75	50	10,0	0,95	0,1	7,48	0,0	2	10,32	10,75	11,09	11,46	11,85	12,73	
03205150	JME142010G4R020Z2.0-HXT	4	G	1,0	6	0,75	50	10,0	0,95	0,2	7,52	0,0	2	10,32	10,74	11,08	11,45	11,84	12,71	
03205154	JME142012G4R005Z2.0-HXT	4	G	1,2	6	0,9	50	12,0	1,15	0,05	6,61	0,0	2	12,32	12,81	13,22	13,66	14,14	15,19	
03205157	JME142012G4R010Z2.0-HXT	4	G	1,2	6	0,9	50	12,0	1,15	0,1	6,62	0,0	2	12,32	12,81	13,22	13,66	14,13	15,18	
03205160	JME142012G4R020Z2.0-HXT	4	G	1,2	6	0,9	50	12,0	1,15	0,2	6,65	0,0	2	12,32	12,8	13,21	13,65	14,12	15,16	
03205164	JME142015G4R005Z2.0-HXT	4	G	1,5	6	1,125	60	15,0	1,45	0,05	5,54	0,0	2	15,32	15,9	16,42	16,97	17,55	18,86	
03205170	JME142015G4R010Z2.0-HXT	4	G	1,5	6	1,125	60	15,0	1,45	0,1	5,55	0,0	2	15,32	15,9	16,41	16,96	17,55	18,85	
03205173	JME142015G4R020Z2.0-HXT	4	G	1,5	6	1,125	60	15,0	1,45	0,2	5,58	0,0	2	15,32	15,9	16,41	16,95	17,53	18,83	

JME142 - Miniature - Hardened steel - Square - 2 Flutes - Cylindrical - Corner radius



Tolerances:

Run-out= <0,005 mm

DMM = h5

DC <0,6 = 0-0,008 mm DC >0,6 = 0-0,01 mm

RE = ±0,005 mm

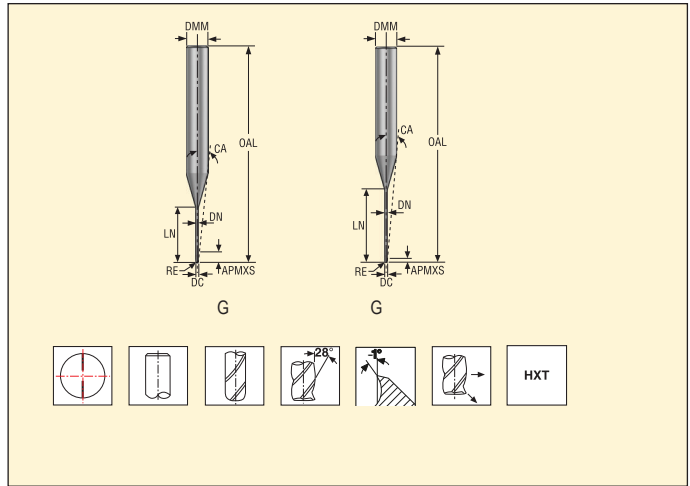

Ordering and Product No.	Designation	Length index	Tool shape	Dimensions in mm								RE	CA	NA	PCEDC	Max. cut depth rel. to α11 (kz1, ref)*					
				DC	DMM	APMXS	OAL	LN	DN	WDX0	WDX05					WDX1	WDX15	WDX2	WDX3		
03205176	JME142018G4R005Z2.0-HXT	4	G	1,8	6	1,35	60	18,0	1,75	0,05	4,68	0,0	2	18,32	19,0	19,61	20,27	20,97	22,53		
03205179	JME142018G4R010Z2.0-HXT	4	G	1,8	6	1,35	60	18,0	1,75	0,1	4,69	0,0	2	18,32	19,0	19,61	20,26	20,96	22,52		
03205182	JME142020G4R005Z2.0-HXT	4	G	2,0	6	1,5	60	20,0	1,94	0,05	4,19	0,0	2	20,35	21,08	21,76	22,49	23,27	25,0		
03205187	JME142020G4R010Z2.0-HXT	4	G	2,0	6	1,5	60	20,0	1,94	0,1	4,19	0,0	2	20,35	21,08	21,76	22,48	23,26	24,99		
03205190	JME142020G4R020Z2.0-HXT	4	G	2,0	6	1,5	60	20,0	1,94	0,2	4,21	0,0	2	20,35	21,07	21,75	22,47	23,25	24,97		
03205194	JME142025G4R005Z2.0-HXT	4	G	2,5	6	1,875	65	25,0	2,4	0,05	3,18	0,0	2	25,47	26,31	27,16	28,07	29,04	31,2		
03205197	JME142025G4R010Z2.0-HXT	4	G	2,5	6	1,875	65	25,0	2,4	0,1	3,19	0,0	2	25,47	26,31	27,16	28,06	29,03	31,19		
03205200	JME142025G4R020Z2.0-HXT	4	G	2,5	6	1,875	65	25,0	2,4	0,2	3,2	0,0	2	25,47	26,3	27,15	28,05	29,02	31,17		
03205207	JME142030G4R010Z2.0-HXT	4	G	3,0	6	2,25	80	30,0	2,85	0,1	2,41	0,0	2	30,59	31,55	32,57	33,66	34,83	∞		
03205210	JME142030G4R020Z2.0-HXT	4	G	3,0	6	2,25	80	30,0	2,85	0,2	2,42	0,0	2	30,59	31,55	32,57	33,65	34,81	∞		
03205213	JME142030G4R030Z2.0-HXT	4	G	3,0	6	2,25	80	30,0	2,85	0,3	2,42	0,0	2	30,59	31,55	32,56	33,64	34,8	∞		
03205143	JME142010G5R005Z2.0-HXT	5	G	1,0	6	0,75	60	15,0	0,95	0,05	5,93	0,0	2	15,32	15,9	16,42	16,97	17,55	18,86		
03205165	JME142015G5R005Z2.0-HXT	5	G	1,5	6	1,125	80	22,5	1,45	0,05	4,2	0,0	2	22,82	23,64	24,4	25,22	26,09	28,04		
03205183	JME142020G5R005Z2.0-HXT	5	G	2,0	6	1,5	80	30,0	1,94	0,05	3,07	0,0	2	30,35	31,39	32,41	33,49	34,65	37,24		
03205203	JME142030G5R005Z2.0-HXT	5	G	3,0	6	2,25	90	45,0	2,85	0,05	1,7	0,0	2	45,59	47,03	48,55	50,17	∞	∞		
03205144	JME142010G6R005Z2.0-HXT	6	G	1,0	6	0,75	60	20,0	0,95	0,05	4,92	0,0	2	20,32	21,06	21,74	22,47	23,25	24,98		
03205166	JME142015G6R005Z2.0-HXT	6	G	1,5	6	1,125	80	30,0	1,45	0,05	3,37	0,0	2	30,32	31,37	32,39	33,47	34,63	37,21		
03205184	JME142020G6R005Z2.0-HXT	6	G	2,0	6	1,5	80	40,0	1,94	0,05	2,42	0,0	2	40,35	41,71	43,06	44,5	46,04	∞		
03205204	JME142030G6R005Z2.0-HXT	6	G	3,0	6	2,25	90	60,0	2,85	0,05	1,31	0,0	2	60,59	62,5	64,52	∞	∞	∞		

Cutting data – JME142 Side rough

SMG		a _p /DC	a _p /DC	f _z													v _c
				0,2	0,3	0,4	0,5	0,6	0,8	1	1,2	1,5	1,8	2	2,5	3	
H3	M/A	0,050	0,30	0,0036	0,0055	0,0070	0,0090	0,011	0,014	0,018	0,022	0,026	0,030	0,030	0,034	0,038	95 (62 – 120)
H5	M/A	0,050	0,46	0,0040	0,0060	0,0080	0,010	0,012	0,016	0,020	0,024	0,030	0,036	0,040	0,050	0,060	170 (140 – 200)
H7	M/A	0,050	0,30	0,0036	0,0055	0,0070	0,0090	0,011	0,014	0,018	0,022	0,026	0,030	0,030	0,034	0,038	95 (62 – 120)
H8	M/A	0,050	0,46	0,0040	0,0060	0,0080	0,010	0,012	0,016	0,020	0,024	0,030	0,034	0,036	0,040	0,044	170 (140 – 200)
H11	M/A	0,050	0,46	0,0040	0,0060	0,0080	0,010	0,012	0,016	0,020	0,024	0,030	0,036	0,040	0,050	0,060	215 (180 – 250)
H12	M/A	0,050	0,46	0,0040	0,0060	0,0080	0,010	0,012	0,016	0,020	0,024	0,030	0,034	0,036	0,040	0,044	200 (170 – 230)
H21	M/A	0,050	0,30	0,0036	0,0055	0,0070	0,0090	0,011	0,014	0,018	0,022	0,026	0,032	0,036	0,040	0,044	170 (150 – 200)
H31	M/A	0,050	0,46	0,0038	0,0055	0,0075	0,0095	0,011	0,015	0,019	0,022	0,026	0,030	0,032	0,036	0,038	130 (110 – 150)

Cutting data – JME142 Slotting

SMG		a _p /DC	f _z													v _c
			0,2	0,3	0,4	0,5	0,6	0,8	1	1,2	1,5	1,8	2	2,5	3	
H3	M/A	0,012	0,0025	0,0038	0,0050	0,0065	0,0075	0,010	0,013	0,015	0,019	0,022	0,025	0,032	0,038	60 (41 – 80)
H5	M/A	0,020	0,0025	0,0038	0,0050	0,0060	0,0075	0,010	0,012	0,015	0,019	0,022	0,025	0,030	0,038	110 (91 – 130)
H7	M/A	0,012	0,0025	0,0038	0,0050	0,0065	0,0075	0,010	0,013	0,015	0,019	0,022	0,025	0,032	0,038	60 (41 – 80)
H8	M/A	0,020	0,0025	0,0038	0,0050	0,0060	0,0075	0,010	0,012	0,015	0,019	0,022	0,025	0,030	0,038	110 (91 – 130)
H11	M/A	0,020	0,0025	0,0038	0,0050	0,0060	0,0075	0,010	0,012	0,015	0,019	0,022	0,025	0,030	0,038	140 (120 – 160)
H12	M/A	0,020	0,0025	0,0038	0,0050	0,0060	0,0075	0,010	0,012	0,015	0,019	0,022	0,025	0,030	0,038	130 (110 – 150)
H21	M/A	0,012	0,0025	0,0038	0,0050	0,0065	0,0075	0,010	0,013	0,015	0,019	0,022	0,025	0,032	0,038	110 (91 – 130)
H31	M/A	0,020	0,0025	0,0038	0,0050	0,0060	0,0075	0,010	0,012	0,015	0,019	0,022	0,025	0,030	0,036	85 (69 – 99)

For cutting data recalculations, see page 411-418.

SMG = Seco material group

Coolant = A=air D=dry E=emulsion M=mist spray

v_c = m/min

f_z = mm

a_p (mm)/DC (mm)= factor

a_e (mm)/DC (mm)= factor

All cutting data are target values

JME144 - Miniature - Hardened steel - Square - 4 Flutes - Cylindrical - Corner radius



Tolerances:

Run-out= <0,005 mm
 DMM=h5
 DC = 0-0,01 mm
 RE= ±0,005 mm

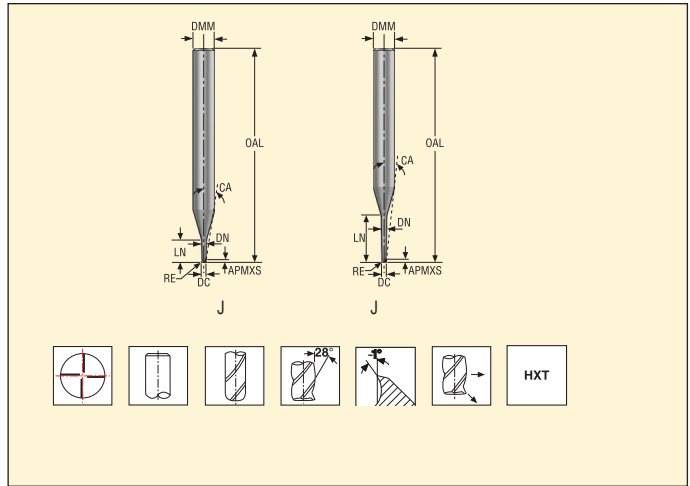

Ordering and Product No.	Designation	Length index	Tool shape	Dimensions in mm									PCEDC	Max. cut depth rel. to α_{11} (kz1, ref)*					
				DC	DMM	APMXS	OAL	LN	DN	RE	CA	NA		WDX0	WDX05	WDX1	WDX15	WDX2	WDX3
03205214	JME144010J2R005Z4.0-HXT	2	J	1,0	4	0,75	40	4,0	0,95	0,05	9,08	0,9	4	2,04	4,12	4,44	4,62	4,78	5,14
03205217	JME144010J2R010Z4.0-HXT	2	J	1,0	4	0,75	40	4,0	0,95	0,1	9,13	0,9	4	2,04	4,11	4,43	4,62	4,78	5,13
03205220	JME144010J2R020Z4.0-HXT	2	J	1,0	4	0,75	40	4,0	0,95	0,2	9,22	0,9	4	2,04	4,09	4,42	4,61	4,76	5,1
03205221	JME144012J2R005Z4.0-HXT	2	J	1,2	4	0,9	50	4,5	1,15	0,05	8,37	0,9	4	2,18	4,59	4,96	5,15	5,33	5,72
03205224	JME144012J2R010Z4.0-HXT	2	J	1,2	4	0,9	50	4,5	1,15	0,1	8,41	0,9	4	2,18	4,59	4,95	5,15	5,33	5,71
03205227	JME144015J2R005Z4.0-HXT	2	J	1,5	4	1,125	50	5,0	1,45	0,05	7,52	0,9	4	2,4	5,09	5,48	5,69	5,88	6,32
03205229	JME144015J2R010Z4.0-HXT	2	J	1,5	4	1,125	50	5,0	1,45	0,1	7,56	0,9	4	2,4	5,08	5,47	5,68	5,87	6,31
03205232	JME144015J2R020Z4.0-HXT	2	J	1,5	4	1,125	50	5,0	1,45	0,2	7,63	0,9	4	2,4	5,06	5,47	5,67	5,86	6,28
03205234	JME144020J2R005Z4.0-HXT	2	J	2,0	4	1,5	50	6,0	1,94	0,05	5,97	0,9	4	3,09	6,16	6,54	6,77	7,0	7,52
03205236	JME144020J2R010Z4.0-HXT	2	J	2,0	4	1,5	50	6,0	1,94	0,1	6,0	0,9	4	3,09	6,15	6,54	6,76	6,99	7,51
03205239	JME144020J2R020Z4.0-HXT	2	J	2,0	4	1,5	50	6,0	1,94	0,2	6,06	0,9	4	3,1	6,14	6,53	6,75	6,98	7,49
03205241	JME144020J2R030Z4.0-HXT	2	J	2,0	4	1,5	50	6,0	1,94	0,3	6,12	0,9	4	3,1	6,13	6,52	6,74	6,97	7,47
03205243	JME144030J2R010Z4.0-HXT	2	J	3,0	4	2,25	50	9,0	2,85	0,1	2,66	0,9	4	6,76	9,44	9,78	10,1	10,45	∞
03205246	JME144030J2R020Z4.0-HXT	2	J	3,0	4	2,25	50	9,0	2,85	0,2	2,69	0,9	4	6,76	9,44	9,77	10,09	10,44	∞
03205215	JME144010J3R005Z4.0-HXT	3	J	1,0	4	0,75	40	5,0	0,95	0,05	8,27	0,9	4	2,04	4,52	5,45	5,66	5,86	6,29
03205218	JME144010J3R010Z4.0-HXT	3	J	1,0	4	0,75	40	5,0	0,95	0,1	8,3	0,9	4	2,04	4,47	5,44	5,66	5,85	6,28
03205222	JME144012J3R005Z4.0-HXT	3	J	1,2	4	0,9	50	6,0	1,15	0,05	7,3	0,9	4	2,18	4,85	6,47	6,71	6,94	7,46
03205225	JME144012J3R010Z4.0-HXT	3	J	1,2	4	0,9	50	6,0	1,15	0,1	7,33	0,9	4	2,18	4,79	6,47	6,71	6,94	7,45
03205228	JME144015J3R005Z4.0-HXT	3	J	1,5	4	1,125	50	7,5	1,45	0,05	6,04	0,9	4	2,4	5,34	8,0	8,29	8,57	9,21
03205230	JME144015J3R010Z4.0-HXT	3	J	1,5	4	1,125	50	7,5	1,45	0,1	6,06	0,9	4	2,4	5,28	8,0	8,28	8,57	9,2
03205235	JME144020J3R005Z4.0-HXT	3	J	2,0	4	1,5	50	10,0	1,94	0,05	4,29	0,9	4	3,09	6,9	10,57	10,93	11,31	12,15
03205237	JME144020J3R010Z4.0-HXT	3	J	2,0	4	1,5	50	10,0	1,94	0,1	4,31	0,9	4	3,09	6,84	10,57	10,92	11,3	12,14
03205242	JME144030J3R005Z4.0-HXT	3	J	3,0	4	2,25	50	15,0	2,85	0,05	1,74	0,9	4	6,76	15,06	15,82	16,35	∞	∞
03205244	JME144030J3R010Z4.0-HXT	3	J	3,0	4	2,25	50	15,0	2,85	0,1	1,75	0,9	4	6,76	15,04	15,82	16,35	∞	∞
03205216	JME144010J4R005Z4.0-HXT	4	J	1,0	4	0,75	40	8,5	0,95	0,05	6,28	0,9	4	2,04	4,52	8,98	9,3	9,63	10,34
03205219	JME144010J4R010Z4.0-HXT	4	J	1,0	4	0,75	40	8,5	0,95	0,1	6,31	0,9	4	2,04	4,47	8,98	9,3	9,62	10,33
03205223	JME144012J4R005Z4.0-HXT	4	J	1,2	4	0,9	50	10,0	1,15	0,05	5,44	0,9	4	2,18	4,85	10,51	10,87	11,25	12,09
03205226	JME144012J4R010Z4.0-HXT	4	J	1,2	4	0,9	50	10,0	1,15	0,1	5,46	0,9	4	2,18	4,79	10,5	10,87	11,24	12,07
03205231	JME144015J4R010Z4.0-HXT	4	J	1,5	4	1,125	60	12,0	1,45	0,1	4,46	0,9	4	2,4	5,28	12,53	12,96	13,41	14,4
03205233	JME144015J4R020Z4.0-HXT	4	J	1,5	4	1,125	60	12,0	1,45	0,2	4,49	0,9	4	2,4	5,17	12,53	12,95	13,4	14,38
03205238	JME144020J4R010Z4.0-HXT	4	J	2,0	4	1,5	60	16,0	1,94	0,1	3,02	0,9	4	3,09	6,84	16,61	17,16	17,76	19,08
03205240	JME144020J4R020Z4.0-HXT	4	J	2,0	4	1,5	60	16,0	1,94	0,2	3,04	0,9	4	3,1	6,72	16,6	17,16	17,74	19,05
03205245	JME144030J4R010Z4.0-HXT	4	J	3,0	4	2,25	60	24,0	2,85	0,1	1,16	0,9	4	6,76	15,09	24,88	∞	∞	∞
03205248	JME144030J4R020Z4.0-HXT	4	J	3,0	4	2,25	60	24,0	2,85	0,2	1,16	0,9	4	6,76	14,97	24,87	∞	∞	∞

Cutting data – JME144 Side rough

SMG		a _e /DC	a _p /DC	f _z						v _c
				1,0	1,2	1,5	2,0	3		
H3	M/A	0,050	0,095	0,010	0,012	0,014	0,017	0,020	95 (63 – 120)	
H5	M/A	0,050	0,22	0,014	0,017	0,020	0,028	0,040	170 (150 – 200)	
H7	M/A	0,050	0,095	0,010	0,012	0,014	0,017	0,020	95 (63 – 120)	
H8	M/A	0,050	0,22	0,014	0,017	0,020	0,025	0,030	170 (150 – 200)	
H11	M/A	0,050	0,22	0,014	0,017	0,020	0,028	0,040	220 (180 – 250)	
H12	M/A	0,050	0,22	0,014	0,017	0,020	0,025	0,030	200 (170 – 230)	
H21	M/A	0,050	0,22	0,014	0,017	0,020	0,025	0,030	170 (150 – 200)	
H31	M/A	0,050	0,22	0,013	0,015	0,018	0,022	0,026	130 (110 – 150)	

Cutting data – JME144 Slotting

SMG		a _p /DC	f _z						v _c
			1,0	1,2	1,5	2,0	3,0		
H3	M	0,012	0,010	0,012	0,014	0,017	0,020	65 (44 – 86)	
H5	M	0,020	0,012	0,014	0,018	0,024	0,032	120 (99 – 140)	
H7	M	0,012	0,010	0,012	0,014	0,017	0,020	65 (44 – 86)	
H8	M	0,020	0,012	0,014	0,016	0,020	0,024	120 (99 – 140)	
H11	M	0,020	0,012	0,014	0,018	0,024	0,032	155 (130 – 180)	
H12	M	0,020	0,012	0,014	0,016	0,020	0,024	140 (120 – 160)	
H21	M	0,012	0,011	0,014	0,016	0,019	0,024	120 (99 – 140)	
H31	M	0,020	0,010	0,012	0,014	0,017	0,022	90 (75 – 100)	

For cutting data recalculations, see page 411-418.

SMG = Seco material group

Coolant = A=air D=dry E=emulsion M=mist spray

v_c = m/min

f_z = mm

a_p (mm)/DC (mm)= factor

a_e (mm)/DC (mm)= factor

All cutting data are target values

JMB112 - Miniature - Hardened steel - Ball nose - 2 Flutes - Cylindrical



Tolerances:

Run-out= <0,005 mm

DMM= h5

DC <0,6 = 0-0,008 mm DC >0,6 = 0-0,01 mm

RE= ±0,004 mm

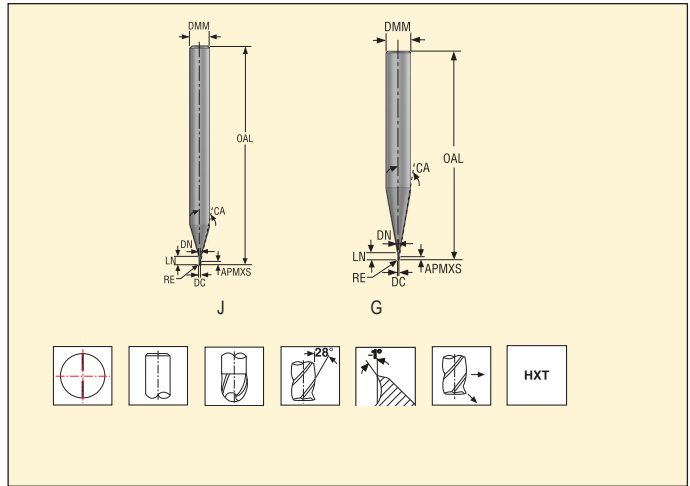

Ordering and Product No.	Designation	Length index	Tool shape	Dimensions in mm										PCEDC	Max. cut depth rel. to αη (λαη, ref)*					
				DC	DMM	APMXS	OAL	LN	DN	RE	CA	NA	WDK0		WDK05	WDK1	WDK15	WDK2	WDK3	
03204964	JMB112002G1BZ2.0-HXT	1	G	0,2	4	0,15	40	0,4	0,18	0,1	15,11	0,0	2	0,49	0,5	0,52	0,54	0,55	0,59	
03204966	JMB112003G1BZ2.0-HXT	1	G	0,3	4	0,225	40	0,6	0,28	0,15	14,77	0,0	2	0,69	0,71	0,73	0,75	0,77	0,82	
03204968	JMB112004G1BZ2.0-HXT	1	G	0,4	4	0,3	40	0,8	0,37	0,2	14,32	0,0	2	0,95	0,97	1,0	1,02	1,05	1,12	
03204970	JMB112005G1BZ2.0-HXT	1	G	0,5	4	0,5	40	1,0	0,46	0,25	13,97	0,0	2	1,15	1,18	1,21	1,24	1,27	1,35	
03204977	JMB112006G1BZ2.0-HXT	1	G	0,6	4	0,6	40	1,2	0,56	0,3	13,64	0,0	2	1,34	1,37	1,41	1,45	1,49	1,58	
03204984	JMB112008G1BZ2.0-HXT	1	G	0,8	6	0,8	50	1,6	0,76	0,4	13,96	0,0	2	1,74	1,78	1,83	1,88	1,93	2,04	
03204991	JMB112010G1BZ2.0-HXT	1	G	1,0	6	1,0	50	2,0	0,95	0,5	13,49	0,0	2	2,14	2,19	2,25	2,31	2,37	2,51	
03205000	JMB112012G1BZ2.0-HXT	1	G	1,2	6	1,2	50	2,4	1,15	0,6	13,02	0,0	2	2,54	2,6	2,67	2,74	2,81	2,98	
03205009	JMB112015G1BZ2.0-HXT	1	G	1,5	6	1,5	50	3,0	1,45	0,75	12,2	0,0	2	3,23	3,31	3,39	3,48	3,57	3,79	
03204965	JMB112002J2BZ2.0-HXT	2	J	0,2	4	0,15	40	0,6	0,18	0,1	14,33	0,9	2	0,51	0,72	0,8	0,87	0,94	1,06	
03204967	JMB112003J2BZ2.0-HXT	2	J	0,3	4	0,225	40	0,9	0,28	0,15	13,85	0,9	2	0,61	0,99	1,11	1,2	12,7	1,42	
03204969	JMB112004J2BZ2.0-HXT	2	J	0,4	4	0,3	40	1,2	0,37	0,2	13,3	0,9	2	1,02	1,35	1,47	1,57	1,65	1,79	
03204971	JMB112005J2BZ2.0-HXT	2	J	0,5	4	0,5	40	1,5	0,46	0,25	12,85	0,9	2	1,53	1,72	1,84	1,93	2,02	2,17	
03204978	JMB112006J2BZ2.0-HXT	2	J	0,6	4	0,6	50	2,0	0,56	0,3	12,09	0,9	2	1,57	2,19	2,35	2,46	2,56	2,74	
03204985	JMB112008J2BZ2.0-HXT	2	J	0,8	4	0,8	50	2,5	0,76	0,4	11,34	0,9	2	1,77	2,67	2,86	2,99	3,1	3,31	
03204992	JMB112010J2BZ2.0-HXT	2	J	1,0	4	1,0	40	4,0	0,95	0,5	9,49	0,9	2	2,29	4,13	4,42	4,59	4,74	5,06	
03205001	JMB112012J2BZ2.0-HXT	2	J	1,2	4	1,2	50	4,5	1,15	0,6	8,83	0,9	2	2,49	4,6	4,93	5,12	5,28	5,63	
03205010	JMB112015J2BZ2.0-HXT	2	J	1,5	4	1,5	50	5,0	1,45	0,75	8,1	0,9	2	2,78	5,09	5,45	5,64	5,81	6,19	
03205019	JMB112018J2BZ2.0-HXT	2	J	1,8	4	1,8	50	5,0	1,75	0,9	7,71	0,9	2	3,08	5,15	5,46	5,64	5,81	6,17	
03205024	JMB112020J2BZ2.0-HXT	2	J	2,0	4	2,0	50	6,0	1,94	1,0	6,6	0,9	2	3,6	6,16	6,5	6,7	6,9	7,34	
03205032	JMB112025J2BZ2.0-HXT	2	J	2,5	4	2,5	50	7,5	2,4	1,25	4,75	0,9	2	5,4	7,81	8,12	8,35	8,59	9,14	
03205037	JMB112030J2BZ2.0-HXT	2	J	3,0	4	3,0	50	9,0	2,85	1,5	3,04	0,9	2	7,53	9,44	9,73	10,01	10,31	10,96	
03204972	JMB112005G2BZ2.0-HXT	2	G	0,5	6	0,5	50	1,5	0,46	0,25	9,91	0,0	2	1,78	1,89	1,98	2,07	2,17	2,41	
03204979	JMB112006G2BZ2.0-HXT	2	G	0,6	6	0,6	50	2,0	0,56	0,3	9,62	0,0	2	2,27	2,41	2,52	2,63	2,76	3,07	
03204986	JMB112008G2BZ2.0-HXT	2	G	0,8	6	0,8	50	2,5	0,76	0,4	9,33	0,0	2	2,77	2,93	3,06	3,2	3,35	3,72	
03204993	JMB112010G2BZ2.0-HXT	2	G	1,0	6	1,0	50	4,0	0,95	0,5	8,49	0,0	2	4,32	4,52	4,72	4,94	5,19	5,77	
03205002	JMB112012G2BZ2.0-HXT	2	G	1,2	6	1,2	50	4,5	1,15	0,6	8,21	0,0	2	4,82	5,04	5,26	5,51	5,78	6,42	
03205011	JMB112015G2BZ2.0-HXT	2	G	1,5	6	1,5	50	5,0	1,45	0,75	10,14	0,0	2	5,32	5,55	5,72	5,89	6,07	6,47	
03205018	JMB112018G2BZ2.0-HXT	2	G	1,8	6	1,8	50	5,0	1,75	0,9	9,99	0,0	2	5,32	5,55	5,71	5,88	6,05	6,44	
03205025	JMB112020G2BZ2.0-HXT	2	G	2,0	6	2,0	50	6,0	1,94	1,0	9,1	0,0	2	6,35	6,6	6,79	6,99	7,2	7,66	
03205033	JMB112025G2BZ2.0-HXT	2	G	2,5	6	2,5	50	7,5	2,4	1,25	7,71	0,0	2	7,97	8,22	8,45	8,69	8,95	9,53	
03205038	JMB112030G2BZ2.0-HXT	2	G	3,0	6	3,0	50	9,0	2,85	1,5	6,35	0,0	2	9,59	9,85	10,12	10,41	10,72	11,42	

JMB112 - Miniature - Hardened steel - Ball nose - 2 Flutes - Cylindrical



Tolerances:

Run-out= <0,005 mm

DMM=h5

DC <0,6 = 0-0,008 mm DC>0,6 = 0-0,01 mm

RE= ±0,004 mm

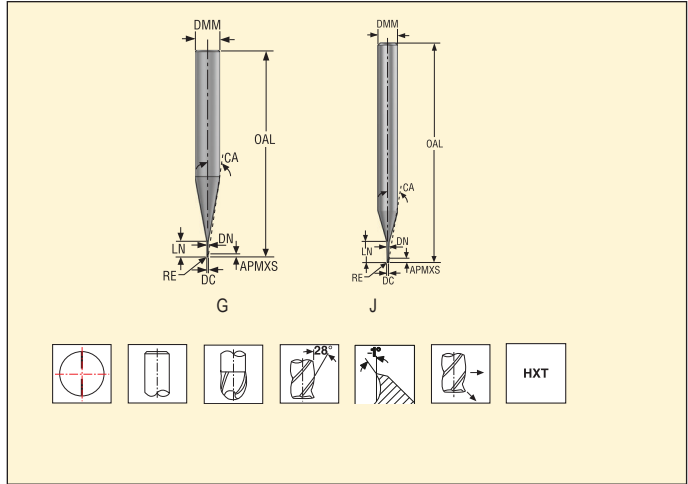

Ordering and Product No.	Designation	Length index	Tool shape	Dimensions in mm								NA	PCEDC	Max. cut depth rel. to αη (ααη, ref)*					
				DC	DMM	APMXS	OAL	LN	DN	RE	CA			WDX0	WDX05	WDX1	WDX15	WDX2	WDX3
03204973	JMB112005J3BZ2.0-HXT	3	J	0,5	4	0,5	40	2,5	0,46	0,25	11,49	0,9	2	1,54	2,63	2,85	2,99	3,11	3,32
03204980	JMB112006J3BZ2.0-HXT	3	J	0,6	4	0,6	40	3,0	0,56	0,3	10,83	0,9	2	1,57	3,07	3,36	3,52	3,65	3,9
03204987	JMB112008J3BZ2.0-HXT	3	J	0,8	4	0,8	40	4,0	0,76	0,4	9,67	0,9	2	1,77	3,52	4,38	4,57	4,72	5,05
03204994	JMB112010J3BZ2.0-HXT	3	J	1,0	4	1,0	40	5,0	0,95	0,5	8,6	0,9	2	2,29	4,57	5,43	5,64	5,82	6,22
03205003	JMB112012J3BZ2.0-HXT	3	J	1,2	4	1,2	50	6,0	1,15	0,6	7,65	0,9	2	2,49	4,9	6,45	6,68	6,89	7,36
03205012	JMB112015J3BZ2.0-HXT	3	J	1,5	4	1,5	40	7,5	1,45	0,75	6,4	0,9	2	2,78	5,33	7,97	8,24	8,5	9,08
03205020	JMB112018J3BZ2.0-HXT	3	J	1,8	4	1,8	50	9,0	1,75	0,9	5,28	0,9	2	3,08	5,81	9,49	9,8	10,11	10,8
03205026	JMB112020J3BZ2.0-HXT	3	J	2,0	4	2,0	50	10,0	1,94	1,0	4,61	0,9	2	3,6	6,86	10,53	10,86	11,21	11,97
03205034	JMB112025J3BZ2.0-HXT	3	J	2,5	4	2,5	50	12,5	2,4	1,25	3,13	0,9	2	5,4	10,6	13,15	13,55	13,97	14,92
03205039	JMB112030J3BZ2.0-HXT	3	J	3,0	4	3,0	50	15,0	2,85	1,5	1,91	0,9	2	7,53	15,03	15,77	16,25	∞	∞
03204974	JMB112005G3BZ2.0-HXT	3	G	0,5	6	0,5	50	3,5	0,46	0,25	8,81	0,0	2	3,78	3,99	4,18	4,38	4,61	5,15
03204981	JMB112006G3BZ2.0-HXT	3	G	0,6	6	0,6	50	4,0	0,56	0,3	8,56	0,0	2	4,27	4,51	4,72	4,94	5,2	5,81
03204988	JMB112008G3BZ2.0-HXT	3	G	0,8	6	0,8	50	5,5	0,76	0,4	10,1	0,0	2	5,77	6,06	6,26	6,46	6,67	7,14
03204995	JMB112010G3BZ2.0-HXT	3	G	1,0	6	1,0	50	7,0	0,95	0,5	9,06	0,0	2	7,32	7,64	7,87	8,12	8,38	8,97
03205004	JMB112012G3BZ2.0-HXT	3	G	1,2	6	1,2	50	8,0	1,15	0,6	8,42	0,0	2	8,32	8,67	8,93	9,21	9,51	10,17
03205013	JMB112015G3BZ2.0-HXT	3	G	1,5	6	1,5	50	10,0	1,45	0,75	7,31	0,0	2	10,32	10,72	11,05	11,39	11,76	12,59
03205021	JMB112018G3BZ2.0-HXT	3	G	1,8	6	1,8	50	12,0	1,75	0,9	6,35	0,0	2	12,32	12,78	13,17	13,58	14,02	15,0
03205027	JMB112020G3BZ2.0-HXT	3	G	2,0	6	2,0	50	12,0	1,94	1,0	6,19	0,0	2	12,35	12,8	13,18	13,59	14,03	15,0
03205035	JMB112025G3BZ2.0-HXT	3	G	2,5	6	2,5	50	15,0	2,4	1,25	4,91	0,0	2	15,47	15,96	16,43	16,94	17,49	18,71
03205040	JMB112030G3BZ2.0-HXT	3	G	3,0	6	3,0	60	15,0	2,85	1,5	4,41	0,0	2	15,59	16,04	16,51	17,01	17,55	18,76
03204975	JMB112005J4BZ2.0-HXT	4	J	0,5	4	0,5	40	4,0	0,46	0,25	9,9	0,9	2	1,54	3,15	4,37	4,57	4,72	5,06
03204982	JMB112006J4BZ2.0-HXT	4	J	0,6	4	0,6	40	5,0	0,56	0,3	8,97	0,9	2	1,57	3,19	5,38	5,61	5,8	6,21
03204989	JMB112008J4BZ2.0-HXT	4	J	0,8	4	0,8	40	7,0	0,76	0,4	7,46	0,9	2	1,77	3,52	7,41	7,7	7,95	8,52
03204996	JMB112010J4BZ2.0-HXT	4	J	1,0	4	1,0	40	8,5	0,95	0,5	6,48	0,9	2	2,29	4,57	8,96	9,28	9,58	10,26
03205005	JMB112012J4BZ2.0-HXT	4	J	1,2	4	1,2	50	10,0	1,15	0,6	5,63	0,9	2	2,49	4,9	10,48	10,84	11,2	11,99
03205014	JMB112015J4BZ2.0-HXT	4	J	1,5	4	1,5	60	12,0	1,45	0,75	4,65	0,9	2	2,78	5,33	12,51	12,92	13,34	14,28
03205022	JMB112018J4BZ2.0-HXT	4	J	1,8	4	1,8	60	15,0	1,75	0,9	3,57	0,9	2	3,08	5,81	15,54	16,04	16,57	17,74
03205028	JMB112020J4BZ2.0-HXT	4	J	2,0	4	2,0	60	16,0	1,94	1,0	3,17	0,9	2	3,6	6,86	16,58	17,11	17,66	18,91
03205041	JMB112030J4BZ2.0-HXT	4	J	3,0	4	3,0	60	24,0	2,85	1,5	1,22	0,9	2	7,53	15,07	24,83	∞	∞	∞
03204976	JMB112005G4BZ2.0-HXT	4	G	0,5	6	0,5	50	5,0	0,46	0,25	10,55	0,0	2	5,28	5,55	5,74	5,93	6,12	6,56
03204983	JMB112006G4BZ2.0-HXT	4	G	0,6	6	0,6	50	6,0	0,56	0,3	9,86	0,0	2	6,27	6,59	6,8	7,02	7,25	7,77
03204990	JMB112008G4BZ2.0-HXT	4	G	0,8	6	0,8	50	8,0	0,76	0,4	8,65	0,0	2	8,27	8,65	8,92	9,21	9,52	10,2
03204998	JMB112010G4BZ2.0-HXT	4	G	1,0	6	1,0	50	10,0	0,95	0,5	7,63	0,0	2	10,32	10,73	11,06	11,42	11,8	12,64
03205006	JMB112012G4BZ2.0-HXT	4	G	1,2	6	1,2	50	12,0	1,15	0,6	8,77	0,0	2	12,32	12,79	13,19	13,61	14,06	15,07
03205015	JMB112015G4BZ2.0-HXT	4	G	1,5	6	1,5	70	15,0	1,45	0,75	5,7	0,0	2	15,32	15,88	16,37	16,9	17,46	18,71
03205023	JMB112018G4BZ2.0-HXT	4	G	1,8	6	1,8	60	18,0	1,75	0,9	4,83	0,0	2	18,32	18,97	19,56	20,18	20,85	22,35
03205029	JMB112020G4BZ2.0-HXT	4	G	2,0	6	2,0	60	18,0	1,94	1,0	4,68	0,0	2	18,35	18,99	19,57	20,19	20,86	22,35
03205036	JMB112025G4BZ2.0-HXT	4	G	2,5	6	2,5	65	25,0	2,4	1,25	3,3	0,0	2	25,47	26,27	27,08	27,95	28,88	30,94
03205042	JMB112030G4BZ2.0-HXT	4	G	3,0	6	3,0	80	30,0	2,85	1,5	2,51	0,0	2	30,59	31,51	32,48	33,52	34,63	∞

JMB112 - Miniature - Hardened steel - Ball nose - 2 Flutes - Cylindrical



Tolerances:

Run-out= <0,005 mm

DMM=h5

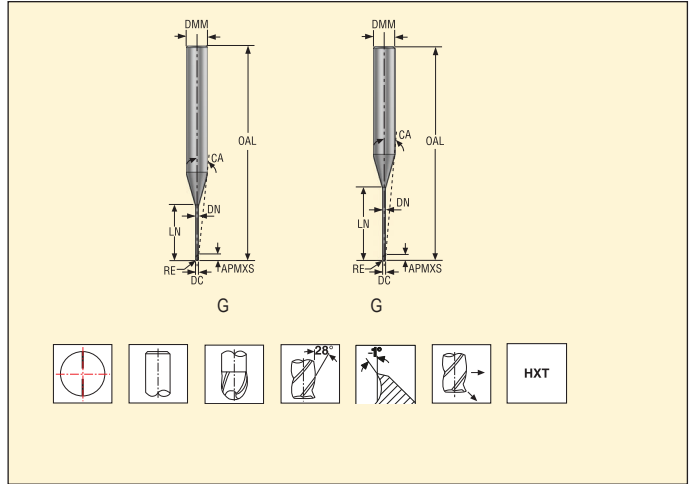

DC <0,6 = 0-0,008 mm DC >0,6 = 0-0,01 mm

RE= ±0,004 mm



Ordering and Product No.	Designation	Length index	Tool shape	Dimensions in mm								CA	NA	PCEDC	Max. cut depth rel. to $\alpha\eta$ ($\alpha\eta$, ref)*					
				DC	DMM	APMXS	OAL	LN	DN	RE	WDX0				WDX05	WDX1	WDX15	WDX2	WDX3	
03204999	JMB112010G5BZ2.0-HXT	5	G	1,0	6	1,0	60	15,0	0,95	0,5	6,04	0,0	2	15,32	15,89	16,39	16,92	17,49	18,76	
03205007	JMB112012G5BZ2.0-HXT	5	G	1,2	6	1,2	60	18,0	1,15	0,6	5,24	0,0	2	18,32	18,98	19,58	20,21	20,89	22,41	
03205016	JMB112015G5BZ2.0-HXT	5	G	1,5	6	1,5	70	22,5	1,45	0,75	4,29	0,0	2	22,82	23,62	24,36	25,15	26,0	27,88	
03205030	JMB112020G5BZ2.0-HXT	5	G	2,0	6	2,0	80	30,0	1,94	1,0	3,15	0,0	2	30,35	31,36	32,35	33,4	34,52	37,03	
03205043	JMB112030G5BZ2.0-HXT	5	G	3,0	6	3,0	90	45,0	2,85	1,5	1,75	0,0	2	45,59	46,98	48,45	50,03	∞	∞	
03205054	JMB112010G6BZ2.0-HXT	6	G	1,0	6	1,0	60	20,0	0,95	0,5	4,99	0,0	2	20,32	21,05	21,71	22,42	23,19	24,92	
03205008	JMB112012G6BZ2.0-HXT	6	G	1,2	6	1,2	70	24,0	1,15	0,6	4,27	0,0	2	24,32	25,17	25,97	26,82	27,73	29,75	
03205017	JMB112015G6BZ2.0-HXT	6	G	1,5	6	1,5	80	30,0	1,45	0,75	3,44	0,0	2	30,32	31,35	32,35	33,4	34,49	37,06	
03205031	JMB112020G6BZ2.0-HXT	6	G	2,0	6	2,0	80	40,0	1,94	1,0	2,47	0,0	2	40,35	41,68	43,0	44,4	45,91	∞	
03205045	JMB112030G6BZ2.0-HXT	6	G	3,0	6	3,0	90	60,0	2,85	1,5	1,34	0,0	2	60,59	62,45	64,43	∞	∞	∞	

Cutting data – JMB112 Copy milling roughing

SMG		a _e /DC	a _p /DC	f _z													
				0,2	0,3	0,4	0,5	0,6	0,8	1	1,2	1,5	1,8	2	2,5	3	
H3	M	0,050	0,30	0,0036	0,0055	0,0070	0,0090	0,011	0,014	0,018	0,020	0,025	0,028	0,030	0,034	0,036	120 (110 – 140)
H5	M	0,050	0,44	0,0040	0,0060	0,0080	0,010	0,012	0,016	0,020	0,024	0,028	0,032	0,034	0,040	0,042	180 (170 – 200)
H7	M	0,050	0,30	0,0036	0,0055	0,0070	0,0090	0,011	0,014	0,018	0,020	0,025	0,028	0,030	0,034	0,036	120 (110 – 140)
H8	M	0,050	0,44	0,0032	0,0046	0,0065	0,0080	0,0095	0,013	0,016	0,018	0,022	0,025	0,026	0,030	0,032	180 (160 – 200)
H11	M	0,050	0,44	0,0040	0,0060	0,0080	0,010	0,012	0,016	0,020	0,024	0,028	0,032	0,034	0,040	0,042	230 (210 – 250)
H12	M	0,050	0,44	0,0032	0,0046	0,0065	0,0080	0,0095	0,013	0,016	0,018	0,022	0,025	0,026	0,030	0,032	210 (190 – 230)
H21	M	0,050	0,44	0,0032	0,0046	0,0065	0,0080	0,0095	0,013	0,016	0,018	0,022	0,025	0,026	0,030	0,032	180 (160 – 200)
H31	M	0,050	0,44	0,0028	0,0040	0,0055	0,0070	0,0080	0,011	0,014	0,016	0,019	0,022	0,022	0,026	0,028	135 (130 – 150)

For cutting data recalculations, see page 411-418.

SMG = Seco material group

Coolant = A=air D=dry E=emulsion M=mist spray

v_c = m/min





























f_z = mm

a_p (mm)/DC (mm)= factor

a_e (mm)/DC (mm)= factor

All cutting data are target values



						
						
Name		JC840	JC845	JC850	JC860	JC870
Page(s)		347-348	349-350	351-352	353-354	355-359
Family name		COMPOSITE	COMPOSITE	COMPOSITE	COMPOSITE	COMPOSITE
Type of mill						
Shank	Cylindrical	■	■	■	■	■
	Weldon					
Number of Flutes		4-9	3	4	5-9	2
ICC						
Diameter range	Metric	6-12	6-8	3-12	6-16	3-12
	Inch					1/4 - 1/2
Length availability		 2	 2	 2	 2	 2
Operation						
						
						
SMG						
TS1						
TS2		•	•	•	•	•
TS3		•	•	•	•	•
TP1						
TP2		•	•	•	•	•
TP3		•	•	•	•	•
Honeycomb*					•	•





























*honeycomb refers to a honeycomb-like base structure.

■ Stock standard • Preferred choice, ○ Alternative choice

Name		JC871	JC875	JC876	JC877	JC880	JC885	JC898	JC899
Page(s)		360-364	365-367	368-370	371-373	374-375	376-377	379	381 - 382
Family name		COMPOSITE	COMPOSITE	COMPOSITE	COMPOSITE	COMPOSITE	COMPOSITE	COMPOSITE	COMPOSITE
Type of mill									
Shank	Cylindrical	■	■	■	■	■	■	■	■
	Weldon								
Number of Flutes		2	5-10	6-14	6-14	4	4	4	4
ICC								■	
Diameter range	Metric	3-12	3-10	3-12	3-12	4-20	4-10	8-15	8,5 - 14,8
	Inch	1/4 -1/2	1/4 -1/2	1/4-1/2	1/4-1/2				3/8
Length availability									
		2	2	2	2	2	2	3	3,4
Operation									
SMG									
TS2		•	•	•	•	•	•		
TS3		•	•	•	•	•	•		
TP2		•	•	•	•	•	•		
TP3		•	•	•	•	•	•		
TS2/TP2+N1								•	•
TS2/TP2+S12								•	•
Honeycomb*		•							

*honeycomb refers to a honeycomb-like base structure.

■ Stock standard • Preferred choice, ○ Alternative choice

						
						
Name		JPD850	JPD880	JPD890	J93F	J28
Page(s)		384-385	386-387	388-389	390-391	392-393
Family name		PCD	PCD	PCD	VHM	VHM
Type of mill						
Shank	Cylindrical	■	■	■	■	■
	Weldon					
Number of Flutes		2-3	3	2	2	1
ICC		■	■	■		
Diameter range	Metric	5-16	6-16	6-16	1-25	2-12
	Inch					
Length availability		 2	 2,3	 2,3	 2,3,4	 2
Operation						
						
						
SMG						
TS1					●	●
TS2		●	●	●		
TS3		●	●	●		
TP1					●	
TP2		●	●	●		
TP3		●	●	●		
Honeycomb*						

*honeycomb refers to a honeycomb-like base structure.

■ Stock standard ● Preferred choice, ○ Alternative choice

Cutting data – JC840 Slot milling

SMG		a_p/DC	f_z					v_c
			6	8	10	12		
TS2	E/A/D	1,0	0,024	0,032	0,040	0,050	150 (100 – 200)	
TS3	E/A/D	1,0	0,024	0,032	0,040	0,050	100 (70 – 130)	
TP2	E/A/D	1,0	0,024	0,032	0,040	0,050	100 (50 – 150)	
TP3	E/A/D	1,0	0,024	0,032	0,040	0,050	75 (45 – 105)	

Cutting data – JC840 Side milling roughing

SMG		a_e/DC	a_p/DC	f_z					v_c
				6	8	10	12		
TS2	E/A/D	0,40	1,2	0,036	0,048	0,060	0,070	170 (115 – 230)	
TS3	E/A/D	0,40	1,2	0,036	0,048	0,060	0,070	115 (80 – 150)	
TP2	E/A/D	0,40	1,2	0,036	0,048	0,060	0,070	115 (55 – 170)	
TP3	E/A/D	0,40	1,2	0,036	0,048	0,060	0,070	85 (50 – 120)	

For cutting data recalculations, see page 411-418.

SMG = Seco material group

Coolant = A=air D=dry E=emulsion M=mist spray

v_c = m/min

f_z = mm

a_p (mm)/DC (mm)= factor

a_e (mm)/DC (mm)= factor

All cutting data are target values

Cutting data – JC845 Slot milling

SMG		a_p/DC	f_z		v_c
			6	8	
TS2	E/A/D	1,0	0,024	0,032	155 (100 – 205)
TS3	E/A/D	0,80	0,024	0,032	105 (70 – 135)
TP2	E/A/D	1,0	0,024	0,032	100 (70 – 155)
TP3	E/A/D	0,80	0,024	0,032	70 (50 – 90)

Cutting data – JC845 Side milling roughing

SMG		a_p/DC	a_p/DC	f_z		v_c
				6	8	
TS2	E/A/D	0,40	1,5	0,036	0,048	175 (115 – 235)
TS3	E/A/D	0,40	1,3	0,036	0,048	120 (80 – 155)
TP2	E/A/D	0,40	1,5	0,036	0,048	115 (80 – 175)
TP3	E/A/D	0,40	1,3	0,036	0,048	80 (60 – 105)

For cutting data recalculations, see page 411-418.

SMG = Seco material group

Coolant = A=air D=dry E=emulsion M=mist spray

v_c = m/min

f_z = mm

a_p (mm)/DC (mm)= factor

a_e (mm)/DC (mm)= factor

All cutting data are target values

Cutting data – JC850 Copy milling

SMG		a_p /DC	a_e /DC	f_z						
				3	4	6	8	10	12	
TS2	E/A/D	0,20	2,0	0,030	0,040	0,060	0,080	0,10	0,12	265 (215 — 320)
TS3	E/A/D	0,20	2,0	0,024	0,032	0,048	0,065	0,080	0,095	160 (105 — 215)
TP2	E/A/D	0,20	2,0	0,030	0,040	0,060	0,080	0,10	0,12	215 (105 — 320)
TP3	E/A/D	0,20	2,0	0,024	0,032	0,048	0,065	0,080	0,095	105 (55 — 160)

For cutting data recalculations, see page 411-418.

SMG = Seco material group

Coolant = A=air D=dry E=emulsion M=mist spray

v_c = m/min

f_z = mm

a_p (mm)/DC (mm)= factor

a_e (mm)/DC (mm)= factor

All cutting data are target values

Cutting data – JC860 Slot milling

SMG		a_p/DC	f_z					
			6	8	10	12	16	
TS2	E/A/D	0,50	0,012	0,016	0,020	0,024	0,032	160 (135 – 185)
TS3	E/A/D	0,50	0,012	0,016	0,020	0,024	0,032	105 (85 – 125)
TP2	E/A/D	0,50	0,012	0,016	0,020	0,024	0,032	110 (85 – 140)
TP3	E/A/D	0,50	0,012	0,016	0,020	0,024	0,032	44 (34 – 80)

Cutting data – JC860 Side milling roughing

SMG		a_e/DC	a_p/DC	f_z					
				6	8	10	12	16	
TS2	E/A/D	0,10	1,0	0,024	0,032	0,040	0,048	0,060	235 (200 – 275)
TS3	E/A/D	0,10	1,0	0,024	0,032	0,040	0,048	0,060	160 (125 – 190)
TP2	E/A/D	0,10	1,0	0,024	0,032	0,040	0,048	0,060	165 (125 – 210)
TP3	E/A/D	0,10	1,0	0,024	0,032	0,040	0,048	0,060	65 (50 – 115)

For cutting data recalculations, see page 411-418.

SMG = Seco material group

Coolant = A=air D=dry E=emulsion M=mist spray

v_c = m/min

f_z = mm

a_p (mm)/DC (mm)= factor

a_e (mm)/DC (mm)= factor

All cutting data are target values

Cutting data – JC870 Slot milling

SMG		a_p/DC	f_z							
			3	4	5	6	8	10	12	
TS2	E/A/D	1,0	0,0060	0,0080	0,010	0,012	0,016	0,020	0,024	145 (120 – 170)
TS3	E/A/D	1,0	0,0060	0,0080	0,010	0,012	0,016	0,020	0,024	100 (80 – 115)
TP2	E/A/D	1,0	0,0060	0,0080	0,010	0,012	0,016	0,020	0,024	100 (75 – 120)
TP3	E/A/D	1,0	0,0060	0,0080	0,010	0,012	0,016	0,020	0,024	39 (29 – 70)

Cutting data – JC870 Side milling roughing

SMG		a_e/DC	a_p/DC	f_z							
				3	4	5	6	8	10	12	
TS2	E/A/D	0,35	2,0	0,0095	0,013	0,016	0,019	0,026	0,032	0,038	175 (145 – 205)
TS3	E/A/D	0,35	2,0	0,0095	0,013	0,016	0,019	0,026	0,032	0,038	115 (95 – 140)
TP2	E/A/D	0,35	2,0	0,0095	0,013	0,016	0,019	0,026	0,032	0,038	115 (90 – 145)
TP3	E/A/D	0,35	2,0	0,0095	0,013	0,016	0,019	0,026	0,032	0,038	46 (35 – 80)

For cutting data recalculations, see page 411-418.

SMG = Seco material group

Coolant = A=air D=dry E=emulsion M=mist spray

v_c = m/min

f_z = mm

a_p (mm)/DC (mm)= factor

a_e (mm)/DC (mm)= factor

All cutting data are target values

Cutting data – JC871 Slot milling

SMG		a _p /DC	f _z								v _c
			3	4	5	6	8	10	12		
TS2	E/A/D	1,0	0,0060	0,0080	0,010	0,012	0,016	0,020	0,024	155 (130 – 180)	
TS3	E/A/D	1,0	0,0060	0,0080	0,010	0,012	0,016	0,020	0,024	100 (80 – 125)	
TP2	E/A/D	1,0	0,0060	0,0080	0,010	0,012	0,016	0,020	0,024	100 (75 – 130)	
TP3	E/A/D	1,0	0,0060	0,0080	0,010	0,012	0,016	0,020	0,024	39 (30 – 70)	

Cutting data – JC871 Side milling roughing

SMG		a _p /DC	f _z								v _c
			3	4	5	6	8	10	12		
TS2	E/A/D	2,0	0,0095	0,013	0,016	0,019	0,026	0,032	0,038	170 (145 – 200)	
TS3	E/A/D	2,0	0,0095	0,013	0,016	0,019	0,026	0,032	0,038	115 (90 – 135)	
TP2	E/A/D	2,0	0,0095	0,013	0,016	0,019	0,026	0,032	0,038	115 (85 – 145)	
TP3	E/A/D	2,0	0,0095	0,013	0,016	0,019	0,026	0,032	0,038	45 (34 – 80)	

For cutting data recalculations, see page 411-418.

SMG = Seco material group

Coolant = A=air D=dry E=emulsion M=mist spray

v_c = m/min

f_z = mm

a_p (mm)/DC (mm)= factor

a_e (mm)/DC (mm)= factor

All cutting data are target values

Cutting data – JC875 Slot milling

SMG		a_p/DC	f_z								v_c
			3	4	5	6	8	10	12		
TS2	E/A/D	1,0	0,0060	0,0080	0,010	0,012	0,016	0,020	0,024	160 (135 – 185)	
TS3	E/A/D	1,0	0,0060	0,0080	0,010	0,012	0,016	0,020	0,024	105 (85 – 130)	
TP2	E/A/D	1,0	0,0060	0,0080	0,010	0,012	0,016	0,020	0,024	105 (80 – 135)	
TP3	E/A/D	1,0	0,0060	0,0080	0,010	0,012	0,016	0,020	0,024	42 (32 – 75)	

Cutting data – JC875 Side milling

SMG		a_e/DC	a_p/DC	f_z								v_c
				3	4	5	6	8	10	12		
TS2	E/A/D	0,35	2,0	0,0095	0,013	0,016	0,019	0,026	0,032	0,038	190 (160 – 225)	
TS3	E/A/D	0,35	2,0	0,0095	0,013	0,016	0,019	0,026	0,032	0,038	130 (100 – 155)	
TP2	E/A/D	0,35	2,0	0,0095	0,013	0,016	0,019	0,026	0,032	0,038	130 (95 – 160)	
TP3	E/A/D	0,35	2,0	0,0095	0,013	0,016	0,019	0,026	0,032	0,038	50 (38 – 90)	

For cutting data recalculations, see page 411-418.

SMG = Seco material group

Coolant = A=air D=dry E=emulsion M=mist spray

v_c = m/min

f_z = mm

a_p (mm)/DC (mm)= factor

a_e (mm)/DC (mm)= factor

All cutting data are target values

Cutting data – JC876 Slot milling

SMG		a_p/DC	f_z							v_c
			3	4	6	8	10	12		
TS2	E/A/D	1,0	0,0060	0,0080	0,012	0,016	0,020	0,024	175 (145 – 205)	
TS3	E/A/D	1,0	0,0060	0,0080	0,012	0,016	0,020	0,024	115 (95 – 140)	
TP2	E/A/D	1,0	0,0060	0,0080	0,012	0,016	0,020	0,024	115 (90 – 145)	
TP3	E/A/D	1,0	0,0060	0,0080	0,012	0,016	0,020	0,024	60 (35 – 80)	

Cutting data – JC876 Side milling roughing

SMG		a_e/DC	a_p/DC	f_z							v_c
				3	4	6	8	10	12		
TS2	E/A/D	0,33	1,7	0,0095	0,013	0,019	0,026	0,032	0,038	220 (185 – 255)	
TS3	E/A/D	0,33	1,7	0,0095	0,013	0,019	0,026	0,032	0,038	145 (115 – 175)	
TP2	E/A/D	0,33	1,7	0,0095	0,013	0,019	0,026	0,032	0,038	145 (110 – 185)	
TP3	E/A/D	0,33	1,7	0,0095	0,013	0,019	0,026	0,032	0,038	75 (44 – 105)	

For cutting data recalculations, see page 411-418.

SMG = Seco material group

Coolant = A=air D=dry E=emulsion M=mist spray

v_c = m/min

f_z = mm

a_p (mm)/DC (mm)= factor

a_e (mm)/DC (mm)= factor

All cutting data are target values

Cutting data – JC877 Slot milling

SMG		a_p/DC	f_z							v_c
			3	4	6	8	10	12		
TS2	E/A/D	1,0	0,0060	0,0080	0,012	0,016	0,020	0,024	170 (145 – 200)	
TS3	E/A/D	1,0	0,0060	0,0080	0,012	0,016	0,020	0,024	115 (90 – 140)	
TP2	E/A/D	1,0	0,0060	0,0080	0,012	0,016	0,020	0,024	115 (85 – 145)	
TP3	E/A/D	1,0	0,0060	0,0080	0,012	0,016	0,020	0,024	55 (34 – 80)	

Cutting data – JC877 Side milling roughing

SMG		a_e/DC	a_p/DC	f_z							v_c
				3	4	6	8	10	12		
TS2	E/A/D	0,33	2,0	0,0095	0,013	0,019	0,026	0,032	0,038	195 (165 – 230)	
TS3	E/A/D	0,33	2,0	0,0095	0,013	0,019	0,026	0,032	0,038	130 (105 – 155)	
TP2	E/A/D	0,33	2,0	0,0095	0,013	0,019	0,026	0,032	0,038	130 (100 – 165)	
TP3	E/A/D	0,33	2,0	0,0095	0,013	0,019	0,026	0,032	0,038	65 (39 – 90)	

For cutting data recalculations, see page 411-418.

SMG = Seco material group

Coolant = A=air D=dry E=emulsion M=mist spray

v_c = m/min

f_z = mm

a_p (mm)/DC (mm)= factor

a_e (mm)/DC (mm)= factor

All cutting data are target values

Cutting data – JC880 Slot milling

SMG		a_p/DC	f_z								
			4	5	6	8	10	12	16	20	
TS2	E/A/D	1,0	0,024	0,030	0,036	0,048	0,060	0,070	0,090	0,10	150 (125 – 175)
TS3	E/A/D	1,0	0,015	0,019	0,022	0,030	0,038	0,044	0,055	0,065	100 (70 – 130)
TP2	E/A/D	1,0	0,024	0,030	0,036	0,048	0,060	0,070	0,090	0,10	100 (75 – 125)
TP3	E/A/D	1,0	0,015	0,019	0,022	0,030	0,038	0,044	0,055	0,065	40 (30 – 70)

Cutting data – JC880 Side milling roughing

SMG		a_g/DC	a_p/DC	f_z							
				4	6	8	10	12	16	20	
TS2	E/A/D	0,40	1,9	0,024	0,036	0,048	0,060	0,070	0,090	0,10	190 (155 – 220)
TS3	E/A/D	0,30	2,0	0,017	0,024	0,034	0,042	0,050	0,060	0,070	130 (90 – 170)
TP2	E/A/D	0,40	1,9	0,024	0,036	0,048	0,060	0,070	0,090	0,10	125 (95 – 155)
TP3	E/A/D	0,30	2,0	0,017	0,024	0,034	0,042	0,050	0,060	0,070	50 (40 – 90)

For cutting data recalculations, see page 411-418.

SMG = Seco material group

Coolant = A=air D=dry E=emulsion M=mist spray

v_c = m/min

f_z = mm

a_p (mm)/DC (mm)= factor

a_g (mm)/DC (mm)= factor

All cutting data are target values

Cutting data – JC885 Slot milling

SMG		a _p /DC	f _z							v _c
			4	5	6	8	10	12		
TS2	E/A/D	1,0	0,024	0,030	0,036	0,048	0,060	0,070	150 (125 – 175)	
TS3	E/A/D	0,70	0,015	0,019	0,022	0,030	0,038	0,044	100 (75 – 130)	
TP2	E/A/D	1,0	0,024	0,030	0,036	0,048	0,060	0,070	100 (75 – 125)	
TP3	E/A/D	0,70	0,015	0,019	0,022	0,030	0,038	0,044	40 (25 – 70)	

Cutting data – JC885 Side milling roughing

SMG		a _e /DC	a _p /DC	f _z							v _c
				4	5	6	8	10	12		
TS2	E/A/D	0,40	2,0	0,024	0,030	0,036	0,048	0,060	0,070	190 (155 – 220)	
TS3	E/A/D	0,30	2,0	0,017	0,020	0,024	0,034	0,042	0,050	130 (100 – 170)	
TP2	E/A/D	0,40	2,0	0,024	0,030	0,036	0,048	0,060	0,070	125 (95 – 155)	
TP3	E/A/D	0,30	2,0	0,017	0,020	0,024	0,034	0,042	0,050	50 (33 – 90)	

For cutting data recalculations, see page 411-418.

SMG = Seco material group

Coolant = A=air D=dry E=emulsion M=mist spray

v_c = m/min

f_z = mm

a_p (mm)/DC (mm)= factor

a_e (mm)/DC (mm)= factor

All cutting data are target values

SIMPLIFY AEROSPACE HYBRID MATERIALS HOLEMAKING WITH TWO-IN-ONE GEOMETRY



Eliminate the risk of CFRP delamination and unstacking stacked materials during holemaking

Increase process precision, efficiency and reliability.

Generate pollution- and scratch free surfaces to reduce production time, cost and scrap with new two-in-one tool geometry.

Reduce tooling costs with longer lasting tools.

Helical interpolation roughing



JC898 for helical interpolation roughing of stacked materials.

High feed frontal teeth geometry and through coolant channel for material removal with through spindle compressed air.



High quality surface finishing in one cycle

Designed with the aerospace industry in mind, JC899 a two-in-one-type geometry finishing tool prevents any delamination or fiber pulling out and generates pollution- free holes, so there is no need to manually unstack stacked materials for chip removal.

Cutting data – JC898 Side milling

SMG		a_g/DC	a_p/DC	f_z		 v_c
				8	15	
S12+TS2/TP2	D	0,30	0,020	0,1	0,15	90 (80-120)
N1+TS2/TP2	D	0,30	0,034	0,12	0,25	120 (90-150)

Cutting data – JC898 Slotting

SMG		a_p/DC	f_z		 v_c
			8	15	
S12+TS2/TP2	D	0.02	0.08	0.1	90 (80-120)
N1+TS2/TP2	D	0.034	0.1	0.10	120 (90-150)

For cutting data recalculations, see page 411-418.

SMG = Seco material group

Coolant = A=air D=dry E=emulsion M=mist spray

v_c = m/min

f_z = mm

a_p (mm)/DC (mm)= factor

a_g (mm)/DC (mm)= factor

All cutting data are target values

Cutting data – JC899 Finishing

SMG		a_e/DC	a_p/DC	f_z			 v_c
				8.5	9.525	14.8	
TP2/TS2+S12	D	0,025	4,0	0,04	0,05	0,075	40 (30 – 50)
TP2/TS2+N1	D	0,025	4,0	0,06	0,07	0,09	60 (50 – 75)

For cutting data recalculations, see page 411-418.

SMG = Seco material group

Coolant = A=air D=dry E=emulsion M=mist spray

v_c = m/min

f_z = mm

a_p (mm)/DC (mm)= factor

a_e (mm)/DC (mm)= factor

All cutting data are target values

Cutting data – JPD850 Copy milling

SMG		a _e /DC	a _p /DC	f _z								v _c
				4	5	6	8	10	12	16		
TS2	E/A/D	0,20	0,50	0,038	0,048	0,055	0,075	0,095	0,11	0,14	560 (470 – 840)	
TS3	E/A/D	0,20	0,50	0,038	0,048	0,055	0,075	0,095	0,11	0,14	310 (265 – 470)	
TP2	E/A/D	0,20	0,50	0,038	0,048	0,055	0,075	0,095	0,11	0,14	900 (750 – 1325)	
TP3	E/A/D	0,20	0,50	0,038	0,048	0,055	0,075	0,095	0,11	0,14	590 (500 – 880)	

For cutting data recalculations, see page 411-418.

SMG = Seco material group

Coolant = A=air D=dry E=emulsion M=mist spray

v_c = m/min

f_z = mm

a_p (mm)/DC (mm)= factor

a_e (mm)/DC (mm)= factor

All cutting data are target values

Cutting data – JPD880 Slot milling

SMG		a_p/DC	f_z						v_c
			6	8	10	12	16		
TS2	E/A/D	1,0	0,055	0,075	0,090	0,11	0,14	385 (325 — 570)	
TS3	E/A/D	1,0	0,055	0,075	0,090	0,11	0,14	210 (175 — 315)	
TP2	E/A/D	1,0	0,055	0,075	0,090	0,11	0,14	620 (510 — 720)	
TP3	E/A/D	1,0	0,055	0,075	0,090	0,11	0,14	395 (335 — 600)	

Cutting data – JPD880 Side milling

SMG		a_e/DC	a_p/DC	f_z						v_c
				6	8	10	12	16		
TS2	E/A/D	0,30	1,2	0,060	0,080	0,10	0,12	0,15	510 (425 — 760)	
TS3	E/A/D	0,30	1,2	0,060	0,080	0,10	0,12	0,15	275 (230 — 415)	
TP2	E/A/D	0,30	1,2	0,060	0,080	0,10	0,12	0,15	810 (680 — 950)	
TP3	E/A/D	0,30	1,2	0,060	0,080	0,10	0,12	0,15	520 (440 — 780)	

For cutting data recalculations, see page 411-418.

SMG = Seco material group

Coolant = A=air D=dry E=emulsion M=mist spray

v_c = m/min

f_z = mm

a_p (mm)/DC (mm)= factor

a_e (mm)/DC (mm)= factor

All cutting data are target values

Cutting data – JPD890 Slot milling

SMG		a_p/DC	f_z						v_c
			6	8	10	12	16		
TS2	E/A/D	1,0	0,060	0,080	0,10	0,12	0,16	375 (315 – 560)	
TS3	E/A/D	1,0	0,042	0,055	0,070	0,085	0,11	225 (185 – 335)	
TP2	E/A/D	1,0	0,060	0,080	0,10	0,12	0,16	600 (500 – 700)	
TP3	E/A/D	1,0	0,042	0,055	0,070	0,085	0,11	420 (355 – 630)	

Cutting data – JPD890 Side milling

SMG		a_e/DC	a_p/DC	f_z						v_c
				6	8	10	12	16		
TS2	E/A/D	0,30	1,2	0,12	0,16	0,20	0,24	0,30	415 (350 – 620)	
TS3	E/A/D	0,20	1,2	0,060	0,080	0,10	0,12	0,15	305 (255 – 455)	
TP2	E/A/D	0,30	1,2	0,12	0,16	0,20	0,24	0,30	670 (560 – 780)	
TP3	E/A/D	0,20	1,2	0,060	0,080	0,10	0,12	0,15	580 (485 – 870)	

For cutting data recalculations, see page 411-418.

SMG = Seco material group

Coolant = A=air D=dry E=emulsion M=mist spray

v_c = m/min

f_z = mm

a_p (mm)/DC (mm)= factor

a_e (mm)/DC (mm)= factor

All cutting data are target values

Cutting data – J93F Slot milling

SMG		a _p /DC	f _z													v _c
			1	2	3	4	5	6	8	10	12	14	16	20	25	
TS1	A	0,50	0,0080	0,016	0,024	0,032	0,040	0,048	0,065	0,080	0,095	0,11	0,13	0,16	0,19	500 (400 — 600)
TP1	A	0,50	0,0080	0,016	0,024	0,032	0,040	0,048	0,065	0,080	0,095	0,11	0,13	0,16	0,19	485 (385 — 580)

Cutting data – J93F Side milling

SMG		a _e /DC	a _p /DC	f _z													v _c
				1	2	3	4	5	6	8	10	12	14	16	20	25	
TS1	A	0,40	1,4	0,010	0,020	0,030	0,040	0,050	0,060	0,080	0,10	0,12	0,14	0,15	0,17	0,20	590 (475 — 710)
TP1	A	0,40	1,4	0,010	0,020	0,030	0,040	0,050	0,060	0,080	0,10	0,12	0,14	0,15	0,17	0,20	570 (460 — 690)

For cutting data recalculations, see page 411-418.

SMG = Seco material group

Coolant = A=air D=dry E=emulsion M=mist spray

v_c = m/min

f_z = mm

a_p (mm)/DC (mm)= factor

a_e (mm)/DC (mm)= factor

All cutting data are target values

Cutting data – J28 Slot milling

SMG		a_p/DC	f_z								v_c
			2	3	4	5	6	8	10	12	
TS1	A/D	1,0	0,018	0,026	0,036	0,044	0,055	0,070	0,090	0,11	400 (300 – 500)

Cutting data – J28 Side milling $a_p/DC=0,4$

SMG		a_p/DC	f_z								v_c
			2	3	4	5	6	8	10	12	
TS1	A/D	1,4	0,024	0,036	0,050	0,060	0,075	0,10	0,12	0,14	465 (350 – 580)

For cutting data recalculations, see page 411-418.

SMG = Seco material group

Coolant = A=air D=dry E=emulsion M=mist spray























v_c = m/min

f_z = mm

a_p (mm)/DC (mm)= factor

All cutting data are target values



					
					
Name		JD620	JD630	JD640	JD660
Page(s)		397-398	399-400	401-402	403-404
Family name		DIAMOND	DIAMOND	DIAMOND	DIAMOND
Type of mill					
Shank	Cylindrical	■	■	■	■
	Weldon				
Number of Flutes		2	3	4	2
ICC					
Diameter range	Metric	3-12	3-8	6-12	3-12
	Inch				
Length availability					
		2,3,4	2,3,4	2,3,4	1,2,3,4,5
Operation					
					
					
SMG					
GR		●	●	●	●

■ Stock standard ● Preferred choice, ○ Alternative choice

Name		JME642	JMB642
Page(s)		405-406	407-408
Family name		MINI DIAMOND	MINI DIAMOND
Type of mill			
Shank	Cylindrical	■	■
	Weldon		
Number of Flutes		2	2
DMM		4	4
Diameter range	Metric	0,2-2,0	0,2-3,0
	Inch		
Length availability		 1,3,5,6,7	 1,3,5,6,7
Operation			
SMG			
GR		•	•

■ Stock standard • Preferred choice, ○ Alternative choice

Cutting data – JD620 VL Slot milling

SMG		a_p/DC	f_z									v_c
			3	4	5	6	8	10	12			
GR1	D	0,50	0,024	0,032	0,040	0,048	0,065	0,080	0,095	630 (530 – 740)		

Cutting data – JD620 VL Side milling

SMG		a_e/DC	a_p/DC	f_z									v_c
				3	4	5	6	8	10	12			
GR1	D	0,50	0,50	0,030	0,040	0,050	0,060	0,080	0,10	0,12	690 (570 – 800)		

For cutting data recalculations, see page 411-418.

SMG = Seco material group

Coolant = A=air D=dry E=emulsion M=mist spray

v_c = m/min

f_z = mm

a_p (mm)/DC (mm)= factor

a_e (mm)/DC (mm)= factor

All cutting data are target values

Cutting data – JD630 Slot milling

SMG		a_p/DC	f_z						v_c
			3	4	5	6	8		
GR1	D	0,50	0,024	0,032	0,040	0,048	0,065	620 (520 — 720)	

Cutting data – JD630 Side milling

SMG		a_e/DC	a_p/DC	f_z						v_c
				3	4	5	6	8		
GR1	D	0,50	1,0	0,030	0,040	0,050	0,060	0,080	680 (570 — 800)	

For cutting data recalculations, see page 411-418.

SMG = Seco material group

Coolant = A=air D=dry E=emulsion M=mist spray

v_c = m/min

f_z = mm

a_p (mm)/DC (mm)= factor

a_e (mm)/DC (mm)= factor

All cutting data are target values

Cutting data – JD640 V Slot milling

SMG		a_p/DC	f_z					v_c
			6	8	10	12		
GR1	D	0,50	0,048	0,065	0,080	0,095	610 (510 – 720)	

Cutting data – JD640 V Side milling

SMG		a_e/DC	a_p/DC	f_z					v_c
				6	8	10	12		
GR1	D	0,50	1,0	0,060	0,080	0,10	0,12	680 (560 – 790)	

For cutting data recalculations, see page 411-418.

SMG = Seco material group

Coolant = A=air D=dry E=emulsion M=mist spray

v_c = m/min

f_z = mm

a_p (mm)/DC (mm)= factor

a_e (mm)/DC (mm)= factor

All cutting data are target values

JD660 – Diamond – Graphite – Ball nose – 2 Flutes – Cylindrical



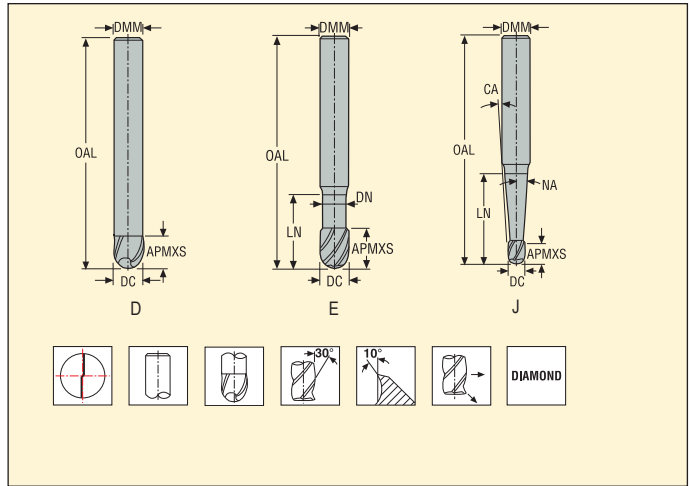

Tolerances:
 Run-out=<0,01 mm
 DMM=h5
 DC= -0,02/-0,04 mm
 RE= ±0,01 mm
 B=0,9°



Ordering and Product No.	Designation	Length index	Tool shape	Dimensions in mm								PCEDC	Max. cut depth rel. to αη (αη, ref)*					
				DC	DMM	APMXS	OAL	DN	LN	CA	NA		WDX0	WDX05	WDX1	WDX15	WDX2	WDX3
00023488	660030-DIAMOND	1	D	3,0	3	8	40	-	-	-	-	2	∞	∞	∞	∞	∞	∞
00023489	660040-DIAMOND	1	D	4,0	4	14	50	-	-	-	-	2	∞	∞	∞	∞	∞	∞
00023490	660050-DIAMOND	1	D	5,0	5	20	50	-	-	-	-	2	∞	∞	∞	∞	∞	∞
00023491	660060-DIAMOND	1	D	6,0	6	20	65	-	-	-	-	2	∞	∞	∞	∞	∞	∞
00023492	660080-DIAMOND	1	D	8,0	8	20	65	-	-	-	-	2	∞	∞	∞	∞	∞	∞
00023493	660100-DIAMOND	1	D	10,0	10	25	75	-	-	-	-	2	∞	∞	∞	∞	∞	∞
00023501	660V030-DIAMOND	2	E	3,0	3	6	40	2,9	15,0	-	0,0	2	∞	∞	∞	∞	∞	∞
00023502	660V040-DIAMOND	2	E	4,0	4	6	40	3,9	15,0	-	0,0	2	∞	∞	∞	∞	∞	∞
00023504	660V050-DIAMOND	2	E	5,0	5	8	40	4,9	15,0	-	0,0	2	∞	∞	∞	∞	∞	∞
00023505	660V060-DIAMOND	2	E	6,0	6	10	65	5,9	35,0	-	0,0	2	∞	∞	∞	∞	∞	∞
00023506	660V080-DIAMOND	2	E	8,0	8	10	65	7,8	35,0	-	0,0	2	∞	∞	∞	∞	∞	∞
00023507	660V100-DIAMOND	2	E	10,0	10	10	75	9,8	40,0	-	0,0	2	∞	∞	∞	∞	∞	∞
00023508	660V120-DIAMOND	2	E	12,0	12	10	75	11,8	40,0	-	0,0	2	∞	∞	∞	∞	∞	∞
00023494	660L030-DIAMOND	3	D	3,0	3	20	60	-	-	-	-	2	∞	∞	∞	∞	∞	∞
00023496	660L040-DIAMOND	3	D	4,0	4	30	60	-	-	-	-	2	∞	∞	∞	∞	∞	∞
00023497	660L050-DIAMOND	3	D	5,0	5	35	70	-	-	-	-	2	∞	∞	∞	∞	∞	∞
00023498	660L060-DIAMOND	3	D	6,0	6	40	100	-	-	-	-	2	∞	∞	∞	∞	∞	∞
00023499	660L080-DIAMOND	3	D	8,0	8	40	100	-	-	-	-	2	∞	∞	∞	∞	∞	∞
00023500	660L100-DIAMOND	3	D	10,0	10	40	100	-	-	-	-	2	∞	∞	∞	∞	∞	∞
00023511	660VL030-DIAMOND	4	E	3,0	3	6	60	2,9	30,0	-	0,0	2	∞	∞	∞	∞	∞	∞
00023512	660VL040-DIAMOND	4	E	4,0	4	6	60	3,9	30,0	-	0,0	2	∞	∞	∞	∞	∞	∞
00023516	660VL060-DIAMOND	4	E	6,0	6	10	100	5,8	70,0	-	0,0	2	∞	∞	∞	∞	∞	∞
00023517	660VL080-DIAMOND	4	E	8,0	8	10	100	7,8	70,0	-	0,0	2	∞	∞	∞	∞	∞	∞
00023518	660VL100-DIAMOND	4	E	10,0	10	10	100	9,8	70,0	-	0,0	2	∞	∞	∞	∞	∞	∞
00023519	660VL120-DIAMOND	4	E	12,0	12	10	100	11,7	70,0	-	0,0	2	∞	∞	∞	∞	∞	∞
00023553	660KL030-DIAMOND	5	J	3,0	5	6	100	2,85	70,0	1,0	0,833	2	11,7	27,0	∞	∞	∞	∞
00023554	660KL040-DIAMOND	5	J	4,0	6	8	100	3,85	70,0	1,0	0,833	2	13,7	31,2	∞	∞	∞	∞

* The effective under-neck length for the various draft angles. Remark ∞ = infinity, no collision in projection length area.

Cutting data – JD660 V (2) Copy milling roughing $a_p/DC=0,4$

SMG		a_p/DC	f_z						
			3	4	5	6	8	10	
GR1	D	2,0	0,042	0,055	0,070	0,085	0,11	0,14	1025 (850 — 1175)

For cutting data recalculations, see page 411-418.

SMG = Seco material group

Coolant = A=air D=dry E=emulsion M=mist spray

v_c = m/min

f_z = mm

a_p (mm)/DC (mm)= factor

All cutting data are target values

JME642 – Miniature – Graphite – Square – Diamond – 2 Flutes – DMM 4 – Cylindrical – Corner radius



Tolerances:
 Run-out= <0,005 mm
 DMM= h5
 DC= 0,-0,015 mm
 RE= ±0,007 mm

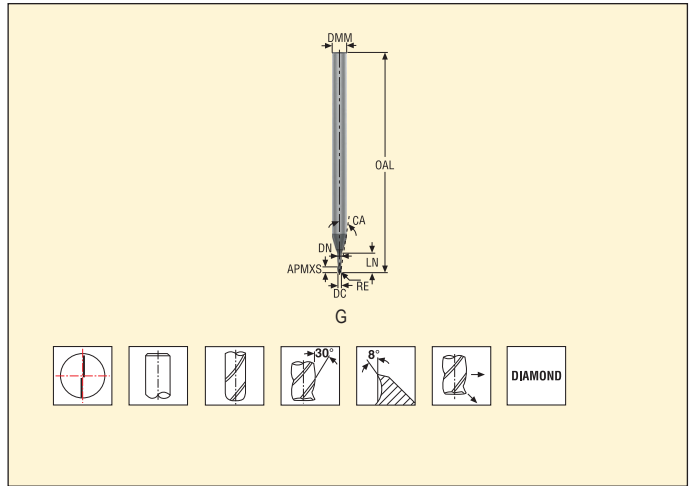

Ordering and Product No.	Designation	Length index	Tool shape	Dimensions in mm								PCEDC	CA	Max. cut depth rel. to α _η (l _{αη} , ref)*					
				DC	DMM	APMXS	OAL	LN	DN	RE	WDX0			WDX05	WDX1	WDX15	WDX2	WDX3	
03215524	JME642002G1R002.0Z2-DIA	1	G	0,2	4	0,3	40	0,4	0,18	0,02	2	14,32	0,59	0,65	0,72	0,78	0,84	0,95	
03215525	JME642003G1R002.0Z2-DIA	1	G	0,3	4	0,5	40	0,5	0,28	0,02	2	14,1	0,74	0,81	0,87	0,94	1,0	1,11	
03215526	JME642004G1R004.0Z2-DIA	1	G	0,4	4	0,6	40	2,0	0,37	0,04	2	11,67	2,29	2,44	2,57	2,68	2,78	2,96	
03215527	JME642005G3R005.0Z2-DIA	3	G	0,5	4	0,7	40	2,5	0,45	0,05	2	10,97	2,83	3,0	3,13	3,25	3,36	3,56	
03215528	JME642006G3R006.0Z2-DIA	3	G	0,6	4	1,0	60	3,0	0,55	0,06	2	10,31	3,33	3,52	3,67	3,8	3,92	4,13	
03215529	JME642008G3R008.0Z2-DIA	3	G	0,8	4	1,2	60	4,0	0,75	0,08	2	9,31	4,33	4,57	4,74	4,89	5,02	5,25	
03215530	JME642010G3R010.0Z2-DIA	3	G	1,0	4	1,6	60	5,0	0,95	0,1	2	8,04	5,33	5,61	5,81	5,97	6,12	6,37	
03215531	JME642012G3R012.0Z2-DIA	3	G	1,2	4	1,6	60	6,0	1,15	0,12	2	7,09	6,33	6,65	6,87	7,05	7,2	7,46	
03215532	JME642015G3R015.0Z2-DIA	3	G	1,5	4	2,4	60	7,5	1,4	0,15	2	5,8	7,99	8,29	8,52	8,71	8,87	9,36	
03236441	JME642020G3R015.0Z2-DIA	3	G	2,0	4	2,2	60	10,0	1,9	0,15	2	4,11	10,53	10,88	11,22	11,55	11,99	12,87	
03215533	JME642020G3R020.0Z2-DIA	3	G	2,0	4	3,0	60	10,0	1,9	0,2	2	4,11	10,49	10,87	11,13	11,35	11,53	12,48	
03215534	JME642005G5R005.0Z2-DIA	5	G	0,5	4	0,7	40	4,0	0,45	0,05	2	9,43	4,33	4,57	4,74	4,89	5,03	5,26	
03215535	JME642006G5R006.0Z2-DIA	5	G	0,6	4	1,0	60	5,0	0,55	0,06	2	8,5	5,33	5,61	5,81	5,98	6,12	6,37	
03215536	JME642008G5R008.0Z2-DIA	5	G	0,8	4	1,2	60	7,0	0,75	0,08	2	7,02	7,33	7,68	7,92	8,12	8,28	8,72	
03215537	JME642010G5R010.0Z2-DIA	5	G	1,0	4	1,6	60	8,5	0,95	0,1	2	6,06	8,33	9,23	9,5	9,71	9,89	10,59	
03215538	JME642012G5R012.0Z2-DIA	5	G	1,2	4	1,6	60	10,0	1,15	0,12	2	5,23	10,33	10,78	11,07	11,3	11,5	12,46	
03215539	JME642015G5R015.0Z2-DIA	5	G	1,5	4	2,4	60	12,0	1,4	0,15	2	4,25	12,49	12,92	13,22	13,32	13,84	14,99	
03236442	JME642020G5R015.0Z2-DIA	5	G	2,0	4	2,2	60	16,0	1,9	0,15	2	2,87	16,53	17,06	17,61	18,91	18,82	∞	
03215540	JME642020G5R020.0Z2-DIA	5	G	2,0	4	3,0	60	16,0	1,9	0,2	2	2,87	16,49	17,02	17,36	17,77	18,45	∞	
03215541	JME642010G6R010.0Z2-DIA	6	G	1,0	4	1,6	60	12,0	0,95	0,1	2	4,86	12,33	12,84	13,16	13,4	13,81	14,96	
03215542	JME642015G6R015.0Z2-DIA	6	G	1,5	4	2,4	50	18,0	1,4	0,15	2	3,13	18,49	19,07	19,43	19,99	20,76	22,49	
03215543	JME642020G6R020.0Z2-DIA	6	G	2,0	4	3,0	60	25,0	1,9	0,2	2	1,97	25,49	26,21	26,78	27,77	28,83	∞	
03215544	JME642020G7R020.0Z2-DIA	7	G	2,0	4	3,0	60	30,0	1,9	0,2	2	1,68	30,49	31,03	32,13	33,32	∞	∞	

Stock standard. Subject to change refer to current price- and stock-list

Cutting data – JME642 Side milling roughing

SMG		a_e/DC	a_p/DC	f_z											v_c
				0,2	0,3	0,4	0,5	0,6	0,8	1	1,2	1,5	2		
GR1	D	0,30	0,80	0,0022	0,0034	0,0046	0,0055	0,0070	0,0090	0,011	0,014	0,016	0,020	170 (120 – 365)	

Cutting data – JME642 Slot milling

SMG		a_p/DC	f_z											v_c
			0,2	0,3	0,4	0,5	0,6	0,8	1	1,2	1,5	2		
GR1	D	0,30	0,0022	0,0034	0,0046	0,0055	0,0070	0,0090	0,011	0,014	0,016	0,024	170 (120 – 250)	

Table based on LV3, please recalc based on length version chosen. See page(s) 411-418

SMG = Seco material group

Coolant = A=air D=dry E=emulsion M=mist spray

v_c = m/min

f_z = mm

a_p (mm)/DC (mm)= factor

a_e (mm)/DC (mm)= factor

All cutting data are target values

JMB642/JMB662 - Miniature - Graphite - Ball nose - Diamond - 2 Flutes - DMM 4-6 - Cylindrical



Tolerances:
 Run-out= <0,005 mm
 DMM= h5
 DC= 0,-0,015 mm
 RE= ±0,007 mm

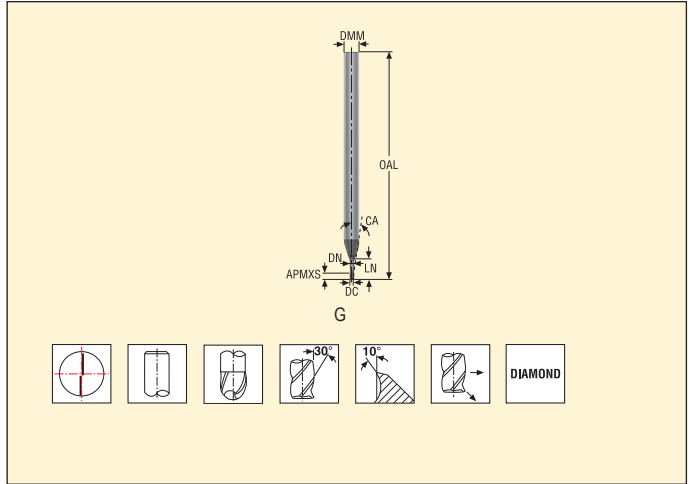

Ordering and Product No.	Designation	Length index	Tool shape	Dimensions in mm						PCEDC	CA	Max. cut depth rel. to $\alpha\eta$ ($\alpha\eta$, ref)*					
				DC	DMM	APMXS	OAL	LN	DN			WDX0	WDX05	WDX1	WDX15	WDX2	WDX3
03215373	JMB642002G1B.0Z2-DIA	1	G	0,2	4	0,3	40	0,4	0,18	2	14,5	0,59	0,65	0,7	0,76	0,81	0,92
03215374	JMB642003G1B.0Z2-DIA	1	G	0,3	4	0,5	40	0,6	0,28	2	14,17	0,74	0,8	0,86	0,91	0,97	1,07
03215375	JMB642004G1B.0Z2-DIA	1	G	0,4	4	2,0	40	0,8	0,37	2	13,8	2,29	2,43	2,55	2,66	2,76	2,93
03215376	JMB642005G3B.0Z2-DIA	3	G	0,5	4	0,7	40	2,5	0,45	2	11,19	2,83	2,99	3,12	3,23	3,34	3,52
03215377	JMB642006G3B.0Z2-DIA	3	G	0,6	4	1,0	60	3,0	0,55	2	10,55	3,33	3,51	3,65	3,78	3,89	4,09
03215378	JMB642008G3B.0Z2-DIA	3	G	0,8	4	1,2	60	4,0	0,75	2	9,38	4,33	4,55	4,72	4,86	4,99	5,21
03215379	JMB642010G3B.0Z2-DIA	3	G	1,0	4	1,6	60	5,0	0,95	2	8,33	5,33	5,59	5,78	5,94	6,08	6,32
03215380	JMB642012G3B.0Z2-DIA	3	G	1,2	4	1,6	60	6,0	1,15	2	7,38	6,33	6,63	6,84	7,01	7,16	7,41
03215381	JMB642015G3B.0Z2-DIA	3	G	1,5	4	2,4	60	7,5	1,4	2	6,08	7,99	8,28	8,49	8,67	8,83	9,33
03215382	JMB642020G3B.0Z2-DIA	3	G	2,0	4	3,0	60	10,0	1,9	2	4,35	10,49	10,84	11,1	11,3	11,5	12,44
03215387	JMB642005G5B.0Z2-DIA	5	G	0,5	4	0,7	40	4,0	0,45	2	9,6	4,33	4,56	4,73	4,88	5,01	5,23
03215388	JMB642006G5B.0Z2-DIA	5	G	0,6	4	1,0	60	5,0	0,55	2	8,68	5,33	5,6	5,79	5,96	6,1	6,34
03215389	JMB642008G5B.0Z2-DIA	5	G	0,8	4	1,2	60	7,0	0,75	2	7,18	7,33	7,67	7,91	8,09	8,26	8,7
03215390	JMB642010G5B.0Z2-DIA	5	G	1,0	4	1,6	60	8,5	0,95	2	6,22	8,83	9,22	9,48	9,68	9,86	10,57
03215391	JMB642012G5B.0Z2-DIA	5	G	1,2	4	1,6	60	10,0	1,15	2	5,4	10,33	10,77	11,05	11,27	11,49	12,44
03215392	JMB642015G5B.0Z2-DIA	5	G	1,5	4	2,4	60	12,0	1,4	2	4,4	12,49	12,91	13,19	13,42	13,81	14,96
03215393	JMB642020G5B.0Z2-DIA	5	G	2,0	4	3,0	60	16,0	1,9	2	2,99	16,49	17,0	17,33	17,75	18,42	19,94
03215396	JMB642010G6B.0Z2-DIA	6	G	1,0	4	1,6	60	12,0	0,95	2	4,96	12,33	12,83	13,14	13,38	13,8	14,94
03215397	JMB642015G6B.0Z2-DIA	6	G	1,5	4	2,4	60	18,0	1,4	2	3,21	18,49	19,05	19,41	19,97	20,74	22,45
03215398	JMB642020G6B.0Z2-DIA	6	G	2,0	4	3,0	60	25,0	1,9	2	2,03	25,49	26,2	26,76	27,75	28,81	∞
03215399	JMB642020G7B.0Z2-DIA	7	G	2,0	4	3,0	60	30,0	1,9	2	1,72	30,49	31,29	32,12	33,3	∞	∞
03215384	JMB662030G3B.0Z2-DIA	3	G	3,0	6	3,0	60	15,0	2,8	2	4,38	15,71	16,1	16,39	16,67	17,3	18,72
03215395	JMB662030G5B.0Z2-DIA	5	G	3,0	6	3,0	60	24,0	2,8	2	3,0	24,71	25,28	25,73	26,67	27,68	29,97

Stock standard. Subject to change refer to current price- and stock-list

Cutting data – JMB642/662 Side milling roughing

SMG		a_e/DC	a_p/DC	f_z										v_c
				0,2	0,3	0,4	0,5	0,6	0,8	1	1,2	1,5	2	
GR1	D	0,30	0,50	0,0024	0,0036	0,0048	0,0060	0,0070	0,0095	0,012	0,014	0,017	0,020	250 (200 – 300)



Cutting data – JMB642/662 Copy milling roughing

SMG		a_e/DC	a_p/DC	f_z										v_c
				0,2	0,3	0,4	0,5	0,6	0,8	1	1,2	1,5	2	
GR1	D	0,50	0,50	0,0024	0,0036	0,0048	—	0,0070	0,0095	0,012	0,014	0,017	0,020	330 (290 – 410)



Table based on LV3, please recalc based on length version chosen. See page(s) 411-418

SMG = Seco material group

Coolant = A=air D=dry E=emulsion M=mist spray

v_c = m/min

f_z = mm

a_p (mm)/DC (mm)= factor

a_e (mm)/DC (mm)= factor

All cutting data are target values





Recalculation (all values are percentages of original (100%) cutting data)

STRAIGHT	Use original standard version side rough cutting data then recalculate parameters!									Use original standard version slotting cutting data then recalculate parameters!								
	Slotting		Side rough			Side finish				Ramping		Helical		Drilling				
	a_p	f_z	a_e	f_z	a_p	v_c	a_e (% of DC)	f_z	a_p	a_p	f_z	f_z	$a_{p,260^\circ}$ (% of DC)	hole \varnothing (\geq % of DC)	f_z	a_p (% of DC)		
JS412 (2)	100	100	100	100	100	140	3	40	120	$\leq 30^\circ$ *		80	100	50	10	130	50	100
JS413 (2) L (3)	100 X	100 X	100 25	100 60	100 240	150 120	3 3	40 40	120 230	$\leq 10^\circ$ *		70 70	50 50	50 50	10 10	130 130	X X	X X
JS452 (2) L (3)	100 50	100 60	100 75	100 60	100 50	140 120	3 3	35 40	120 100	$\leq 30^\circ$ *		70 70	100 70	50 50	10 10	130 130	50 20	100 10
JS453 (2) L (3)	100 X	100 X	100 25	100 60	100 240	140 120	3 3	35 40	120 230	$\leq 10^\circ$ *		70 70	50 70	50 50	10 10	130 130	20 20	10 10
JS512 Standard (2) L (3) XL (4)	100 30 X	100 100 X	100 25 X	100 50 X	100 170 X	110 110 70	3 3 3	65 65 65	125 210 290	$\leq 30^\circ$ *		40 X X	40 X X	100 X X	3 X X	130 X X	40 X X	40 X X
JS513 Standard (2) L (3) XL (4)	100 30 X	100 100 X	100 30 X	100 50 X	100 200 X	110 110 70	3 3 3	85 85 85	150 250 350	$\leq 5^\circ$ *		100 X X	100 X X	100 X X	3 X X	130 X X	50 X X	40 X X
JS514 Standard (2) L (3) XL (4)	100 X X	100 X X	100 25 X	100 50 X	100 200 X	110 110 70	3 3 3	60 60 60	150 250 350	$\leq 5^\circ$ *		100 X X	100 X X	100 X X	3 X X	130 X X	X X X	X X X
JS553 Standard (2) L (3)	100 40	100 60	100 40	100 105	100 200	110 110	3 3	55 55	150 250	$\leq 45^\circ$ *		50 50	55 15	35 35	3 3	130 130	35 35	50 50
JS554 Standard (2) L (3)	100 40	100 60	100 38	100 105	100 200	110 110	3 3	53 53	150 250	$\leq 5^\circ$ *		100 50	100 50	100 60	3 3	130 130	X X	X X
JS564 Standard (2) L (3)	X X	X X	100 38	100 105	100 140	110 110	3 3	55 55	100 140	$\leq 5^\circ$ *		X X	X X	100 60	2 1,5	130 130	X X	X X
JS565 Standard (2) L (3)	X X	X X	100 38	100 105	100 140	110 110	3 3	55 55	100 140	$\leq 5^\circ$ *		X X	X X	100 60	2 1,5	130 130	X X	X X

*Max ramping angle

Recalculation (all values are percentages of original (100%) cutting data)

STRAIGHT	Use original standard version side rough cutting data then recalculate parameters!									Use original standard version slotting cutting data then recalculate parameters!							
	Slotting		Side rough			Side finish				Ramping		Helical		Drilling			
				a_p	f_z	v_c	a_e (% of DC)	f_z	a_p	a_p	f_z	f_z	$a_p/360^\circ$ (% of DC)	Hole \varnothing (\geq % of DC)	f_z	a_p (% of DC)	
J28 Standard (2)	100	100	100	100	100	140	3	100	135	$\leq 45^\circ *$	40	25	100	10	130	25	60
J36 Standard (2)	X	X	100	100	100	120	3	85	150	$\leq X^\circ *$	X	X	X	X	X	X	X
J93F Standard (2)	100	100	100	100	100	133	3	40	100	$\leq 20^\circ *$	100	100	100	3	130	25	30
JH120 Standard (2)	100	100	100	100	100	120	3	120	80	$\leq 1^\circ$	17	100	100	2	130	X	X
JH130 Standard (2)	X	X	100	100	100	120	3	120	80	$\leq X^\circ *$	X	X	X	X	X	X	X
JH142 (2)	X	X	100	100	100	110	3	80	70	$\leq X^\circ *$	X	X	30	2	130	X	X
JH142 (3)	X	X	100	100	100	110	3	80	70		X	X	20	1	130	X	X
JH142 (6)	X	X	100	100	100	110	3	80	70		X	X	10	1	130	X	X
JH830 Standard (2)	100	100	100	100	100	110	3	110	80	$\leq 45^\circ *$	9	135	135	3	130	X	X
JH910 Standard (2)	100	100	100	100	100	125	4	100	80	$\leq X^\circ *$	15	140	140	3	130	X	X
L (3)	80	80	100	80	80	125	4	80	65		10	110	110	3	130	X	X
JH930 Standard (2)	X	X	100	100	100	125	2	30	100	$\leq X^\circ *$	X	X	X	X	X	X	X

*Max ramping angle

Recalculation (all values are percentages of original (100%) cutting data)

STRAIGHT	Use original standard version side rough cutting data then recalculate parameters!									Use original standard version slotting cutting data then recalculate parameters!						
	Slotting		Side rough			Side finish				Ramping		Helical			Drilling	
	a_p	f_z	a_e	f_z	a_p	v_c	a_e (% of DC)	f_z	a_p	a_p	f_z	f_z	a_p ^{2/60°} (% of DC)	hole Ø (≥ % of DC)	f_z	a_p (% of DC)
JH40 Standard (2) K (1)	100	100	100	100	100	100	3	35	100	≤ 5° *						
	100	100	100	100	100	100	3	35	100	83	55	55	25	130	55	80
JH410 Standard (2) TL (2) RS (2) ML (2) L (3) L-RS (3)	100	100	100	100	100	125	2	25	100	≤ 45° *						
	125	100	100	100	100	100	2	100	100	100	67	67	40	130	67	80
	125	100	100	100	100	100	2	100	100	100	50	100	40	130	150	80
	75	60	80	60	100	125	2	25	100	100	50	100	40	130	150	80
	50	35	50	40	100	125	2	10	100	60	40	40	40	130	40	50
	95	95	80	100	100	100	2	100	100	40	30	30	40	130	30	30
JH421 Standard (2) L (3)	100	100	100	100	100	100	4	35	100	≤ 45° *						
	60	60	100	60	60	100	4	20	60	100	100	100	25	130	45	80
JH440 Standard (2)	100	100	100	100	100	125	3	40	100	≤ 30° *						
JHP750 Standard (2) K (1)	100	100	100	100	100	100	2	145	100	≤ 5° *						
JHP951 Standard (2)	100	100	100	100	100	158	2	50	113	100	100	100	5	130	X	X
	115	120	115	115	100	100	2	145	100	≤ 5° *						
JHP993 Standard (2) L (3)	100	100	100	100	100	X	X	X	X	≤ 10° *						
JS520 Standard (2) L (3)	X	X	100	100	100	133	2	65	100	≤ X° *						
	X	X	X	X	X	133	2	65	175	X	X	X	X	X	X	X
JS522 (4)	X	X	100	100	100	129	2	140	100	≤ X° *						
JS720	X	X	100	100	100	110	2	65	100	X	X	X	X	X	X	X
JS754 Standard (2) ML (3)	100	100	100	100	100	110	3	55	150	≤ X° *						
	40	60	38	105	200	110	3	55	250	100	100	100	3	130	X	X
JS755 Standard (2) ML (3)	100	100	100	100	100	110	3	55	150	≤ X° *						
	40	60	38	105	100	110	3	55	250	100	100	100	3	130	X	X

*Max ramping angle

Recalculation (all values are percentages of original (100%) cutting data)

STRAIGHT	Use original standard version side rough cutting data then recalculate parameters!									Use original standard version side milling cutting data then recalculate parameters!						
	Slotting		Side rough			Side finish				Ramping		Helical			Drilling	
	a_p	f_z	a_e	f_z	a_p	v_c	a_e (% of DC)	f_z	a_p	a_p	f_z	f_z	$a_p/360^\circ$ (% of DC)	hole \varnothing (\geq % of DC)	f_z	a_p (% of DC)
$\leq X^\circ$																
JME542-562-564	100	100	100	100	100	125	2	150	5	X	X	X	X	X	X	X
Standard (1)	63	100	100	100	65	125	2	150	3	X	X	X	X	X	X	X
ML (2)	25	100	100	100	25	125	2	150	1	X	X	X	X	X	X	X
L (3)	18	100	100	100	20	125	2	150	1	X	X	X	X	X	X	X
TL (3)	12	100	100	100	10	125	2	150	1	X	X	X	X	X	X	X
XL (4)	10	100	100	100	10	125	2	150	1	X	X	X	X	X	X	X
SL (4)	4	100	100	100	5	125	2	150	1	X	X	X	X	X	X	X
XXL (5)	2	100	100	100	2	125	2	150	1	X	X	X	X	X	X	X
XSL (6)																
$\leq X^\circ$																
JME142-144	100	100	100	100	100	100	2	150	5	X	X	X	X	X	X	X
Standard (1)	85	85	100	100	63	100	2	150	3	X	X	X	X	X	X	X
ML (2)	75	75	100	100	25	100	2	150	1	X	X	X	X	X	X	X
L (3)	60	60	100	100	20	100	2	150	1	X	X	X	X	X	X	X
TL (4)	50	50	100	100	10	100	2	150	1	X	X	X	X	X	X	X
XL (5)	40	40	100	100	5	100	2	150	1	X	X	X	X	X	X	X
SL (6)																
$\leq X^\circ +$																
JM403-404-406	100	100	100	100	100	X	X	X	X	X	X	X	X	X	X	X
Standard (1)	100	75	100	75	100	X	X	X	X	X	X	X	X	X	X	X
ML (2)	100	75	100	75	90	X	X	X	X	X	X	X	X	X	X	X
L (3)	90	75	100	75	70	X	X	X	X	X	X	X	X	X	X	X
TL (3)	75	75	100	75	70	X	X	X	X	X	X	X	X	X	X	X
XL (4)	75	75	100	75	45	X	X	X	X	X	X	X	X	X	X	X
SL (4)	50	50	100	50	30	X	X	X	X	X	X	X	X	X	X	X
XXL (5)																
≤ 2																
JC898	X	X	100	100	100	X	X	X	X	X	50	80	3	130-160	X	X
LV3																
$\leq 5^\circ$																
JC899	X	X	100	100	100	100	3	50	100	X	X	X	X	X	X	X
LV3																

*Max ramping angle

Recalculation (all values are percentages of original (100%) cutting data)

STRAIGHT	Use original standard version side rough cutting data then recalculate parameters!									Use original standard version slotting cutting data then recalculate parameters!							
	Slotting		Side rough			Side finish				Ramping		Helical			Drilling		
	a_p	f_z	a_e	f_z	a_p	v_c	a_p (% of DC)	f_z	a_p	a_p	f_z	f_z	$a_p/360^\circ$ (% of DC)	hole ϕ (\geq % of DC)	f_z	a_p (% of DC)	
JHP170 Standard (2)	100	100	100	100	100	130	3	175	80	$\leq 1^\circ$	100	100	100	2	130	X	X
JHP490 Standard (2)	100	100	100	100	100	X	X	X	X	$\leq 30^\circ$	50	50	35	5	130	30	50
V (2)	100	75	100	100	100	X	X	X	X	50	50	35	5	130	30	50	
VL (3)	100	75	80	100	100	X	X	X	X	50	50	35	5	130	30	50	
VXL (4)	150	75	80	100	100	X	X	X	X	50	50	35	5	130	30	50	
JHP760 Standard (2)	100	100	100	100	100	140	2	125	15	$\leq 5^\circ$	30	100	100	3	130	10	50
L (3)	50	50	100	50	50	140	2	125	15	15	50	50	3	130	5	25	
JHP770 Standard (2)	100	100	100	100	100	170	3	125	100	$\leq 15^\circ$	100	40	40	3	130	X	X
JHP780 Standard (2)	100	100	100	100	100	160	2	135	140	$\leq 5^\circ$	100	100	35	3	130	35	50
JHP780 LV1 Standard	100	100	100	100	100	160	2	135	140	100	100	35	3	130	35	50	
JHP780 LV2 Standard	65	100	100	100	65	160	2	135	65	65	100	35	3	130	35	50	
JD620 Standard (2)	100	100	100	100	100	100	2	110	4	$\leq X^\circ$	X	X	X	X	X	X	X
VL (3)	100	100	100	100	100	100	2	110	4	X	X	X	X	X	X	X	
VSL (4)	20	100	60	100	60	100	2	110	4	X	X	X	X	X	X	X	
JD630 Standard (2)	100	100	100	100	100	100	2	110	4	$\leq X^\circ$	X	X	X	X	X	X	X
V (3)	100	100	100	100	100	100	2	110	4	X	X	X	X	X	X	X	
VL (4)	100	100	100	100	100	100	2	110	4	X	X	X	X	X	X	X	
JD640 Standard (2)	100	100	100	100	100	100	2	110	4	$\leq X^\circ$	X	X	X	X	X	X	X
V (3)	100	100	100	100	100	100	2	110	4	X	X	X	X	X	X	X	
VL (4)	100	100	100	100	100	100	2	110	4	X	X	X	X	X	X	X	

*Max ramping angle

Recalculation (all values are percentages of original (100%) cutting data)

STRAIGHT	Use original standard version side rough cutting data then recalculate parameters!									Use original standard version slotting cutting data then recalculate parameters!								
	Slotting		Side rough			Side finish				Ramping		Helical			Plunging			
	a_p	f_z	a_e	f_z	a_p	v_c	a_e (% of DC)	f_z	a_p	a_p	f_z	f_z	$a_p/360^\circ$ (% of DC)	hole \varnothing (\geq % of DC)	v_c	a_e (% of DC)	f_z	a_{p-sd} (% of DC)
JHF181 (1)	100	100	100	100	100	X	X	X	X	X	X	100	3,4	130	X	X	X	X
JHF181 (1)	80	85	100	85	80	X	X	X	X	X	X	85	3,0	130	X	X	X	X
JHF181 (1)	60	70	100	70	60	X	X	X	X	X	X	70	2,5	130	X	X	X	X
$\leq 1,5^\circ$ *																		
JHF980 K+ Standard (1,2)	100	100	100	100	100	X	X	X	X	X	X	100	3	130	70	30	33	200
ML (3)	80	85	80	85	80	X	X	X	X	X	X	80	3	130	70	30	33	200
TL (4)	50	70	50	70	60	X	X	X	X	X	X	70	3	130	70	30	33	200
$\leq 1,5^\circ$ *																		
JHP180 Standard (1)	100	100	100	100	100	X	X	X	X	X	X	100	3,4	130	X	X	X	X
ML (2)	80	85	100	85	80	X	X	X	X	X	X	80	2,8	130	X	X	X	X
L (3)	60	70	100	70	60	X	X	X	X	X	X	60	2,1	125	X	X	X	X
TL (3)	40	50	100	50	40	X	X	X	X	X	X	40	1,4	120	X	X	X	X

*Max ramping angle

Recalculation (all values are percentages of original (100%) cutting data)

BALL	Use original standard version side rough cutting data then recalculate parameters!									Use original standard version slotting cutting data then recalculate parameters!										
	Slotting			Side rough			Side finish			Copy milling roughing			Copy milling finishing			Helical				
	a_p	f_z		a_e	f_z	a_p	v_c	a_e (% of DC)	f_z	a_p	a_e	f_z	a_p	v_c	a_e (% of DC)	f_z	a_p	f_z	$a_{p,360^\circ}$ (% of DC)	hole \varnothing (\pm % of DC)
JS532 Standard (1) L (2) XL (3)	X	X		100	100	100	125	3	125	10	X	X	X	X	X	X	X	75	5	130
	X	X		70	100	70	125	3	125	10	X	X	X	X	X	X	X	75	5	130
	X	X		X	X	X	125	3	125	10	X	X	X	X	X	X	X	X	X	X
JS533 Standard (1) L (2)	X	X		100	100	100	125	3	125	15	X	X	X	X	X	X	X	75	5	130
	X	X		75	75	75	125	3	125	15	X	X	X	X	X	X	X	75	5	130
JS534 Standard (1) L (2) XL (3)	X	X		100	100	100	125	3	170	20	X	X	X	X	X	X	X	100	3	130
	X	X		70	100	70	125	3	170	20	X	X	X	X	X	X	X	100	3	130
	X	X		70	100	70	125	3	170	20	X	X	X	X	X	X	X	100	3	130
JH970 Standard (2)	X	X		100	100	100	155	2	30	15	X	X	X	X	X	X	X	40	3	130
JH720 Standard (2)	X	X		100	100	100	125	2	90	75	X	X	X	X	X	X	X	40	3	130
JH112 (1)	X	X		100	100	100	110	2	70	100	X	X	X	X	X	X	X	20	2	130
JH112 (2)	X	X		100	100	100	110	2	70	100	X	X	X	X	X	X	X	20	2	130
JH112 (3)	X	X		100	100	100	110	1,6	55	100	X	X	X	X	X	X	X	X	X	X
JH112 (4)	X	X		100	100	100	130	1,4	55	100	X	X	X	X	X	X	X	X	X	X
JH112 (5)	X	X		100	100	100	130	1,4	50	100	X	X	X	X	X	X	X	X	X	X
JH112 (6)	X	X		100	100	100	130	1	35	100	X	X	X	X	X	X	X	X	X	X
JH150 Standard	X	X		100	100	100	165	1	90	35	X	X	X	X	X	X	X	30	2	130

*Max ramping angle

Recalculation (all values are percentages of original (100%) cutting data)

BALL	Use original standard version side rough cutting data then recalculate parameters!									Use original standard version slotting cutting data then recalculate parameters!										
	Slotting			Side rough			Side finish			Copy milling roughing			Copy milling finishing			Helical				
	a_p	f_z		a_e	f_z	a_p	v_c	a_p (% of DC)	f_z	a_p	a_e	f_z	a_p	v_c	a_p (% of DC)	f_z	a_p	f_z	$a_p, 150^\circ$ (% of DC)	hole ϕ (\pm % of DC)
JH160 Standard (2)	X	X		X	X	X	X	X	X	X	X	X	X	X	X	X	X	X	X	X
JH450 Standard (2)	X	X		100	100	100	120	5	90	25	X	X	X	X	X	X	45	5	130	
JH460 Standard (2)	X	X		100	100	100	120	5	90	25	X	X	X	X	X	X	X	X	X	X
JMB542-562-563 Standard (1)	100	100	X	X	X	X	X	X	X	X	100	100	100	125	2	150	5	X	X	X
ML (2)	65	100	X	X	X	X	X	X	X	X	100	100	63	125	2	150	3	X	X	X
L (3)	26	100	X	X	X	X	X	X	X	X	100	100	25	125	2	150	1	X	X	X
TL (4)	20	100	X	X	X	X	X	X	X	X	100	100	19	125	2	150	1	X	X	X
XL (4)	12	100	X	X	X	X	X	X	X	X	100	100	12	125	2	150	1	X	X	X
SL (5)	10	100	X	X	X	X	X	X	X	X	100	100	10	125	2	150	1	X	X	X
XXL (6)	4	100	X	X	X	X	X	X	X	X	100	100	4	125	2	150	1	X	X	X
XSL (7)	2	100	X	X	X	X	X	X	X	X	100	100	2	125	2	150	1	X	X	X
JMB112 Standard (1)	100	100	X	X	X	X	X	X	X	X	100	100	100	118	2	120	5	X	X	X
M(2)	65	100	X	X	X	X	X	X	X	X	64	85	85	118	2	120	3	X	X	X
L (3)	26	100	X	X	X	X	X	X	X	X	56	75	75	118	2	120	1	X	X	X
XL (4)	20	100	X	X	X	X	X	X	X	X	45	60	60	118	2	120	1	X	X	X
XXL (5)	10	100	X	X	X	X	X	X	X	X	38	50	50	118	2	120	1	X	X	X
XSL (6)	4	100	X	X	X	X	X	X	X	X	30	40	40	118	2	120	1	X	X	X
JM413-414-416 Standard (1)	X	X	100	100	100	100	5	40	35	X	X	X	X	X	X	X	X	X	X	X
ML(2)	X	X	100	60	100	100	5	40	15	X	X	X	X	X	X	X	X	X	X	X
L (3)	X	X	100	80	100	100	5	40	15	X	X	X	X	X	X	X	X	X	X	X
XL (5)	X	X	100	60	75	100	5	40	10	X	X	X	X	X	X	X	X	X	X	X
JD660 Standard (1)	X	X	100	100	100	100	2	100	100	X	X	X	X	X	X	X	X	X	X	X
L (3)	X	X	100	100	100	100	2	100	100	X	X	X	X	X	X	X	X	X	X	X
V (2)	X	X	100	100	100	100	2	100	100	X	X	X	X	X	X	X	X	X	X	X
VL (4)	X	X	100	100	100	100	2	100	100	X	X	X	X	X	X	X	X	X	X	X
KL (5)	X	X	100	100	100	100	2	100	100	X	X	X	X	X	X	X	X	X	X	X

*Max ramping angle

Nomenclature and formulae

RPM

$$n = \frac{v_c \cdot 1000}{\pi \cdot D_c} \quad (\text{rev/min})$$

Cutting speed

$$v_c = \frac{n \cdot \pi \cdot D_c}{1000} \quad (\text{m/min})$$

Feed speed

$$v_f = n \cdot Z_n \cdot f_z \quad (\text{mm/min})$$

Feed per revolution

$$f = Z_n \cdot f_z \quad (\text{mm/rev})$$

Metal removal rate

$$Q = \frac{a_e \cdot a_p \cdot v_f}{1000} \quad (\text{cm}^3/\text{min})$$

Cutting speed and RPM for copying

$$v_c = \frac{n \cdot \pi \cdot D_w}{1000} \quad (\text{m/min})$$

$$n = \frac{v_c \cdot 1000}{\pi \cdot D_w} \quad (\text{RPM})$$

$$D_w = 2 \cdot \sqrt{a_p (D_c - a_p)} \quad (\text{mm})$$

Calculation of a_p vs. overhang length :

If the overhang length (XS) is longer than 4 x DC and Cylindrical shanks are used it is important to adopt another depth of cut (a_p) value than that indicated in the table.

Use the following formula to calculate the new a_p value

$$a_{p\text{new}} = a_p \times (4 \times \text{DC}/\text{XS})^2$$

Profile height

$$H = \frac{D_c}{2} - \frac{\sqrt{D_c^2 - a_p^2}}{2}$$

$$D_w = 2 \cdot \sqrt{a_p (D_c - a_p)} \quad (\text{mm})$$

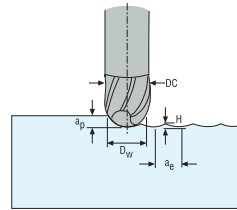

Profile height H (um)

DC	Pitch a_e (μm)						
	0,06	0,08	0,11	0,15	0,20	0,3	0,45
1	0,90	1,60	3,00	5,70	10,0	23,0	53,0
2	0,45	0,80	1,50	2,80	5,0	11,0	26,0
4	0,23	0,40	0,76	1,40	2,5	5,60	13,0
6	0,15	0,27	0,50	0,94	1,7	3,80	8,40
8	0,11	0,20	0,38	0,70	1,3	2,80	6,30
10	0,09	0,16	0,30	0,56	1,0	2,30	5,10
12	0,08	0,13	0,25	0,47	0,83	1,90	4,20

a_p = Depth of cut mm/axial depth of cut (mm)

a_e = Width of cut mm/radial depth of cut (mm)

DC = Cutter diameter

f = Feed per revolution (mm/rev)

f_z = Feed per tooth (mm/tooth)

Z_n = No. of teeth

n = RPM (rev/min)

Q = Material removal rate (cm^3/min)

v_c = Cutting speed (m/min)

v_f = Feed speed (mm/min)

D_w = Working diameter

Measurement drawing should be read as follows:

- DMM = Shank diameter
- CHW = Chamfer
- DC = Milling cutting diameter
- M = Minimum clamping length
- OAL = Total length
- LN = Maximum milling cutter depth
- APMXS = Effective cutting length
- RE = Corner radius
- RE2 = Radius behind the cutting edge
- DN = Neck reduction

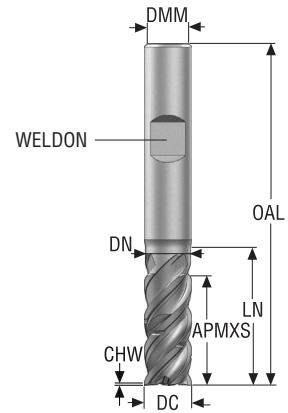

Ramping

The table below shows the feed rate percentage to use at certain ramping angles

Recommended diameter of hole for helical interpolation ramping

Diameter of end mill DC	Diameter of hole
1-2,5	1,4 x DC
3-6	1,3 x DC
8-12	1,2 x DC
16-32	1,15 x DC

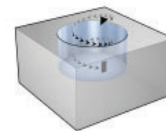

Trochoidal method

The figure below shows a method often called the trochoidal method for milling slots

Recommendation of width of slot

Diameter of end mill DC	Slot width
1-2,5	1,8 x DC
3-6	1,6 x DC
8-12	1,4 x DC
16-32	1,2 x DC

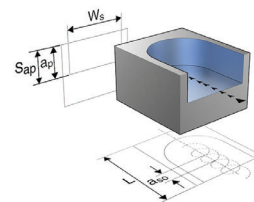

SMG – Introduction

The foundation for SMG is a classification of workpiece materials based on their type rather than their relative machinability and consequently it contains workpiece materials like composites. It is comprehensive enough, but still easy to identify to which SMG a particular material belongs.

Each SMG has a specific material standard in a specific condition assigned as reference to allow easy adjustment of cutting data for any actual material compared to any Seco reference material see pages 422 - 425.

As example the reference materials EN C45E for SMG P4 and EN 42 CrMo 4 for both SMG P5 and SMG H5 see further details in the following tables.

In SMG classification of workpiece materials involves a specific material standard in a specific condition assigned as reference for easy and unambiguous adjustment of cutting data for any actual material compared to any Seco reference material. As examples the reference materials EN C45E for SMG P4 and EN 42 CrMo 4 for both SMG P5 and SMG H5 shown below in table 1 where the reference level material property is indicated.

SMG	Description	Properties	Reference	SMG	Description	Properties	Reference
P4	Low-alloy general structural steels, 0.25% < C < 0.67%wt	520 < R _m < 1200	C 45E R _m = 660 N/mm ²	H5	Quenched & Tempered steels	38 < HRC < 56	42 CrMo 4 50 HRC
	Low-alloy Quench & Temper steels						
P5	Structural steels, 0.25% < C < 0.67%wt Quench & Temper steels	550 < R _m < 1200	42 CrMo 4 R _m = 700 N/mm ²				

Focusing specifically on EN 42 CrMo 4 in annealed condition, the ultimate tensile strength R_m may typically vary between R_m = 630 N/mm² and R_m = 780 N/mm², which provide a reference level for SMG P5. In Quenched & Tempered condition, the ultimate tensile strength R_m may typically be between R_m = 900 N/mm² and R_m = 1100 N/mm² thus still belongs to SMG P5. However, if hardened above R_m = 1200 N/mm² it now belongs to SMG H5.

SMG	EN	W-Nr	AFNOR	BS	UNI	JIS	AISI / ASTM	GOST	Condition	R _{m, nom}	HRC _{nom}
P5	42 CrMo 4	1.1201	42 CD 4	708 M 40	42 CrMo 4	SCM 440 (H)	4142, 4140	38HM	Annealed	700	
	42 CrMo 4	1.1201	42 CD 4	708 M 40	42 CrMo 4	SCM 440 (H)	4142, 4140	38HM	Quenched & Tempered	1000	
H5	42 CrMo 4	1.1201	42 CD 4	708 M 40	42 CrMo 4	SCM 440 (H)	4142, 4140	38HM	Quenched & Tempered		45
	42 CrMo 4	1.1201	42 CD 4	708 M 40	42 CrMo 4	SCM 440 (H)	4142, 4140	38HM	Quenched & Tempered		50

The EN 42CrMo4 quench & tempered steel could be used to illustrate the machinability dependence of materials' condition.

The graphs below indicate how speed recommendations for a nominal material conditions may be adjusted for relative R_m (left diagram valid for ISO-P) and for relative HRC (valid for ISO-H).

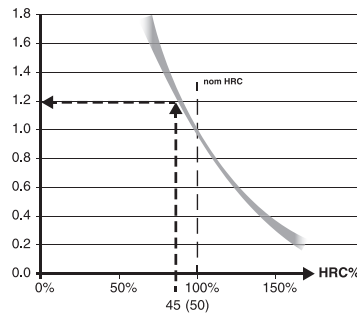
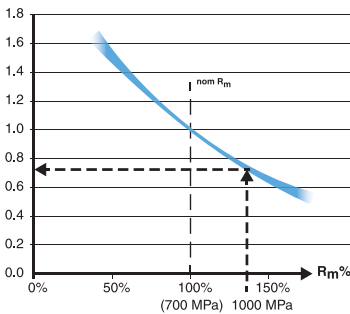

To further illustrate how the SMG P5 nominal v_c can be adjusted to a more accurate recommended v_c we need ultimate tensile strength R_m data and in this case we use the EN 42 CrMo 4 quenched & tempered to R_m = 1000 N/mm² according to above table (bold blue arrows).

Assume that we find that the SMG P5 nominal v_c = 280 m/min for a certain product and machining.

Then, actual recommended v_c = 280 m/min x 0,75 = 210 m/min.

Consequently in the SMG H5 the nominal v_c can be adjusted using the hardened EN 42 CrMo 4 at HRC 45 (smaller grey arrows).

Assume that the SMG H5 nominal v_c = 50 m/min for a certain product and machining using a coated cemented carbide tool then, actual recommended v_c = 50 m/min x 1,2 = 60 m/min.

For further workpiece material details please see page(s) 426-433 and suggested cutting data at applicable pages.

For more convenient cutting data handling we recommend applicable tools in My Pages – Suggest on www.secotools.com

Steels, ferritic and martensitic stainless steels

SMG	Description	Properties	Reference	$k_{c1.1}$	m_c
P1	Free-cutting steels	$360 < R_m < 880$	11 SMn30 $R_m = 385 \text{ N/mm}^2$	1500	0,14
P2	Low-alloy ferritic steels, $C < 0.25\%wt$ Low-alloy weldable general structural steels	$320 < R_m < 600$	S235JRG2 $R_m = 420 \text{ N/mm}^2$	1600	0,23
P3	Ferritic & ferritic/pearlitic steels, $C < 0.25\%wt$ Weldable general structural steels Case-hardening steels	$430 < R_m < 610$	16 MnCr 5 $R_m = 550 \text{ N/mm}^2$	1800	0,14
P4	Low-alloy general structural steels, $0.25\% < C < 0.67\%wt$ Low-alloy Quench & Temper steels	$520 < R_m < 1200$	C 45E $R_m = 660 \text{ N/mm}^2$	2000	0,15
P5	Structural steels, $0.25\% < C < 0.67\%wt$ Quench & Temper steels	$550 < R_m < 1200$	42 CrMo 4 $R_m = 700 \text{ N/mm}^2$	2020	0,18
P6	Low-alloy through-hardening steels, $C > 0.67\%wt$ Low-alloy spring and bearing steels	$520 < R_m < 1200$	C 100S $R_m = 600 \text{ N/mm}^2$	2100	0,17
P7	Through-hardening steels, $C > 0.67\%wt$ Spring and bearing steels	$600 < R_m < 1200$	100 Cr 6 $R_m = 650 \text{ N/mm}^2$	2160	0,17
P8	Tool steels High Speed Steels (HSS)	$600 < R_m < 1200$	X 40 CrMoV 5 1 $R_m = 700 \text{ N/mm}^2$	2400	0,20
P11	Ferritic & martensitic stainless steels	$415 < R_m < 1200$	X 20 Cr 13 $R_m = 675 \text{ N/mm}^2$	2000	0,15
P12	Maraging and precipitation-hardening stainless steels	$500 < R_m < 1200$	X 5 CrNiCuNb 16 4 $R_m = 1100 \text{ N/mm}^2$	2100	0,17

Free-cutting, austenitic and duplex stainless steels

SMG	Description	Properties	Reference	$k_{c1.1}$	m_c
M1	Free-cutting austenitic stainless steels		X 10 CrNiS 18 9	1700	0,14
M2	Low-alloy austenitic stainless steels		X 5 CrNi 18 10	1920	0,18
M3	Medium-alloy austenitic stainless steels		X 2 CrNiMo 18 14 3	2070	0,17
M4	High-alloy austenitic and duplex stainless steels		X 2 CrNiMoN 22 5 3	2230	0,16
M5	Difficult high-alloy austenitic and duplex stainless steels		X 2 CrNiMoN 25 7 4	2510	0,13

Cast irons

SMG	Description	Properties	Reference	$k_{c1.1}$	m_c
K1	Grey cast irons (GCI)		EN-GJL-250	930	0,32
K2	Compacted graphite irons (CGI)		EN-GJV-400	1000	0,35
K3	Malleable cast irons (MCI)		EN-GJMB-550-4	1050	0,37
K4	Nodular cast irons (SGI)		EN-GJS-500-7	1160	0,37
K5	Austempered ductile irons (ADI)		EN-GJS-1000-5		
K6	Austenitic lamellar cast irons		EN-GJLA-XNiCuCr15-6-2		
K7	Austenitic nodular cast irons		EN-GJSA-XNiMn23-4		

Non-ferrous metals

SMG	Description	Properties	Reference	$k_{c1.1}$	m_c
N1	Aluminium alloys, Si < 9%		AW-7075		
N2	Aluminium alloys, 9% < Si < 16%		AC-44200 Si = 12%		
N3	Aluminium alloys, Si > 16%		AlSi17Cu5		
N11	Copper alloys		CW614N	740	0,26

Superalloys and titanium

SMG	Description	Properties	Reference	$k_{c1.1}$	m_c
S1	Iron-based superalloys		Disalloy		
S2	Cobalt-based superalloys		Stellite 21		
S3	Nickel-based superalloys		Inconel 718	2530	0,21
S11	Titanium, low alloyed, (α)		Ti		
S12	Titanium, medium alloyed, ($\alpha+\beta$)		TiAl6V4	1500	0,24
S13	Titanium, high alloyed, (near β and β)		Ti10V2Fe3Al		

Hard materials

SMG	Description	Properties	Reference	$k_{c1.1}$	m_c
H3	Case-hardened steels	58 < HRC < 62	16 MnCr 5 60 HRC	2070	0,14
H5	Quenched & Tempered steels	38 < HRC < 56	42 CrMo 4 50 HRC	2320	0,18
H7	Quenched & Tempered steels Bearing steels	56 < HRC < 64	100 Cr 6 60 HRC	2480	0,17
H8	Tool steels High Speed Steels (HSS)	38 < HRC < 64	X 40 CrMoV 5 1 50 HRC	2750	0,20
H11	Martensitic stainless steels	38 < HRC < 50	X 20 Cr 13 45 HRC	2300	0,15
H12	Maraged and precipitation-hardened stainless steels	1200 < R_m < 1650	X 5 CrNiCuNb 16 4 $R_m = 1450 \text{ N/mm}^2$	2410	0,17
H21	Manganese steels	23 < HRC < 64	X 120 Mn 12 50 HRC		
H31	White cast irons	50 < HRC < 64	EN-GJN-HV600(XCr11) 55 HRC		

Other difficult materials

SMG	Description	Properties	Reference	$k_{c1.1}$	m_c
PM1	Low-alloy PM-materials		F-0008 Fe-0.7C		
PM2	Medium-alloy PM-materials		FLC-4608 Fe2Cu1.8Ni 0.5Mo0.2Mn0.8C		
PM3	High-alloy PM-materials Exhaust valve seat materials, etc.				
HF1	Hardfacing alloys Welded or plasma-deposited iron-based alloys				
HF2	Hardfacing alloys Welded or plasma-deposited cobalt- and nickel-based alloys				
CC1	Sintered tungsten carbide		G50		

Plastics and Composites

SMG	Description	Properties	Reference	$k_{c1.1}$	m_c
TS1	Thermosetting polymers		Urea formaldehyde (UF)		
TS2	Thermosetting carbon-fibre composites		T300 T700 T800 HTA-S IMA - Epoxy (M21)...		
TS3	Thermosetting glass-fibre composites		Epoxy - HX..(42..)E glass (7781...)...		
TS4	Thermosetting aramide-fibre composites		Kevlar 49		
TP1	Thermoplastic polymers		Polycarbonate (PC)		
TP2	Thermoplastic carbon-fibre composites		PPS/PEEK - T300..		
TP3	Thermoplastic glass-fibre composites		PPS/PEEK - E glass or A glass...		
TP4	Thermoplastic aramide-fibre composites				

Graphite

SMG	Description	Properties	Reference	$k_{c1.1}$	m_c
GR1	Graphite		R 8500		

SMG

SMG	EN	EN-Nr	W-Nr	DIN	AFNOR	BS	UNI	JIS	SS	UNS
P1	11 SMn 30	1.0715	1.0715	9 SMn 28	S 250	230 M 07	CF 9 SMn 28	SUM 22	1912	G12130
	11 SMnPb 30	1.0718	1.0718	9 SMnPb 28	S 250 Pb		CF 9 SMnPb 28	SUM 22 L	1914	G12134
	10 S 20	1.0721	1.0721	10 S 20	10 F 1	210 M 15	CF 10 S 20			
			1.0722	10 SPb 20	10 PbF 2		CF 10 SPb 20			
	15 SMn 13	1.0725	1.0723	15 S 20		210 A 15		SUM 32	1922	
	35 S20	1.0726	1.0726	35 S 20	35 MF 4	212 M 36			1957	G11400
	46 S20	1.0727	1.0727	46 S 20	45 MF 4	212 M 44			1973	G11460
	11 SMn 37	1.0736	1.0736	9 SMn 36	S 300	240 M 07	CF 9 SMn 36			G12150
	11 SMn 37	1.0736	1.0736	9 SMn 36	S 300	240 M 07	CF 9 SMn 36			G12150
	S235JR	1.0037	1.0037	St 37-2	E 24-2		Fe 360 B	STKM 12 C	1311	
	S235JRG2	1.0038	1.0116	St 37-3	E 24-3, E 24-4	4360-40 C	Fe 360 D FF		1312, 1313	
S275J2G3	1.0144	1.0144	St 44-3 N	E 28-3, E 28-4	4360-43 C	Fe 430 D FF	SM 41 C	1412, 1414		
C 10	1.0301	1.0301	C 10	34 C 10, XC 10	045 M 10	C 10	S 10 C		G10100	
		1.0401	C 15	37 C 12, XC 18	080 M 15	C 15, C 16		1350	G10170	
C22	1.0402	1.0402	C 22	C 20	050 A 20	C 20, C 21		1450	G10200	
S355JR	1.0570	1.0570	St 52-3	E 36-3, E 36-4	4360-50 C	Fe 510 B	SM 50 YA	2172, 2132		
C 15R	1.1141	1.1141	Ck 15	XC 15, XC 18	080 M 15	C 15, C 16	S 15 C, S 15 CK	1370	G10170	
		1.1158	Ck 25	XC 25	060 A 25	C 25	S 25 C		G10250	
		1.2162	21 MnCr 5	20 NC 5			SCR 420 H			
P3	16 Mo 3	1.5415	1.5415	15 Mo 3	15 D 3	1501-240	16 Mo 3		2912	
			1.5423	16 Mo 5		1503-245-420	16 Mo 5	SB 450 M		G45200
	14 NiCr 14	1.5752	1.5752	14 NiCr 14	12 NC 15	655 M 13		SNC 815 (H)		G33106
			1.5919	15 CrNi 6	16 NC 6	S 107	16 CrNi 4			
	18 NiCrMo 7 6	1.6587	1.6587	18 CrNiMo 7 6	18 NCD 6	820 A 16	18 NiCrMo 7			
	16 MnCr 5	1.7131	1.7131	16 MnCr 5	16 MC 5	527 M 17	16 MnCr 5	SCR 415	2511	G51170
	16 MnCrS 5	1.7139	1.7139	16 MnCrS 5						
	20 MnCr 5	1.7147	1.7147	20 MnCr 5	20 MC 5		20 MnCr 5	SMnC 420 (H)		G51200
	20 MnCrS 5	1.7149	1.7149	20 MnCrS 5	20 MnCrS 5			SMnC 21 H		
	13 CrMo 4 5	1.7335	1.7335	13 CrMo 4 4	15 CD 3,5	1501-620 Gr. 27	14 CrMo 4 5		2216	
			1.7337	16 CrMo 4 4	15 CD 4,5	1501-620 Gr. 27	14 CrMo 4 5		2216	
10 CrMo 9 10	1.7380	1.7380	10 CrMo 9 10	10 CD 9,10	1501-622 Gr. 31	12 CrMo 9 10		2218	J21890	
P4	C35		1.0501	C 35	55 C 35	060 A 35	C 35		1550	G10350
	E 335	1.0503	1.0503	C 45	65 C 45	80 M 46	C 45	S 45 C	1650	G10430
	C40		1.0511	C 40	60 C 40	080 M 40	C 40	S 40 C		
	E 360	1.0070	1.0535	St 70-2	A 70-2		Fe 690		1655	
	C60	1.0601	1.0601	C 60	CC 55	080 A 62	C 60			G10600
			1.1157	40 Mn 4	35 M 5	150 M 36				G10390
	G 28 Mn6	1.1165	1.1165	30 Mn 5		120 M 36		SMn 1 H, SCMn 2		G13300
	C 35E	1.1181	1.1181	Ck 35	XC 38 H1	080 M 36	C 35	S 35 C	1572	G10340
	C 45E	1.1191	1.1191	Ck 45	XC 42	080 M 46	C 45	S 45 C	1672	G10420
	C 60E	1.1221	1.1221	Ck 60	XC 60	080 A 62	C 60	S 58 C	1665, 1678	G10640
			1.1740	C 60 W	Y3 55			SK 7		
P5	55 SiCr7	1.7100	1.0904	55 Si 7	55 S 7	250 A 53	55 Si 8		2085, 2090	
			1.2330	35 CrMo 4	34 CD 4	708 A 37	35 CrMo 4		2234	T51620
			1.2542	45 WCrV 7		BS 1	45 WCrV 8 KU		2710	T41901
		1.2714	1.2714	56 NiCrMoV 7		BH 224-5	56 NiCrMoV7-KU	SKT 4		T61206
			1.5121	46 MnSi 4						
			1.5710	36 NiCr 6	35 NC 6	640 A 35		SNC 236		
			1.5736	36 NiCr 10	35 NC 11		35 NiCr 9	SNC 631 (H)		
	36 CrNiMo 4		1.6511	36 CrNiMo 4	40 NCD 3	816 M 40	38 NiCrMo 4 (KB)			G98400
	34 CrNiMo 6	1.6582	1.6582	34 CrNiMo 6	35 NCD 6	817 M 40	35 NiCrMo 6 (KW)	SNCM 447	2541	G43400
	34 Cr 4	1.7033	1.7033	34 Cr 4	32 C 4	530 A 32	34 Cr 4 (KB)	SCR 430 (H)		G51320
	41 Cr 4	1.7035	1.7035	41 Cr 4	42 C 4	530 M 40	41 Cr 4	SCR 440 (H)		G51400
25 CrMo 4	1.7218	1.7218	25 CrMo 4	25 CD 4 S	708 M 25	25 CrMo 4 (KB)	SCM 425	2225	G41300	
42 CrMo 4	1.7225	1.7225	42 CrMo 4	42 CD 4	708 M 40	42 CrMo 4	SCM 440 (H)	2244	G41400	
42 CrMo 4	1.7225	1.7225	42 CrMo 4	42 CD 4	708 M 40	42 CrMo 4	SCM 440 (H)	2244	G41400	
		1.7361	32 CrMo 12	30 CD 12	722 M 24	32 CrMo 12		2240		
50 CrV 4	1.8159	1.8159	50 CrV 4	50 CV 4	735 A 50	51 CrV 4	SUP 10	2230	H61500	
41 CrAlMo 7 10	1.8509	1.8509	41 CrAlMo 7	40 CAD 6.12	905 M 39	41 CrAlMo 7	SACM 645	2940	K24065	
P6	C 67S	1.1231	1.1231	Ck 67	XC 68	060 A 67	C 70		1770	G10700
	C 100S	1.1274	1.1274	Ck 101		060 A 96		SUP 4	1870	G10950
	C 105U	1.1545	1.1545	C 105 W1	Y1 105		C 100 KU	SK 3		
			1.1663	C 125 W	Y2 120		C 120 KU	SK 2		

SMG

U.N.E./I.H.A.	AISI / ASTM	GOST	ČSN	Misc. Brands	Condition	Structure
	1213				Annealed	
	12 L 13				Annealed	
	1108				Annealed	
	11 L 08				Annealed	
					Annealed	
	1140	40			Annealed	
	1146				Annealed	
	1215				Annealed	
	12 L 14				Annealed	
		16D			Annealed	
	A573 Grade 58	18kp	11 378		Annealed	
	A573 Grade 70	SI14kP	11 448		Annealed	
	1010	10			Annealed	
F.1110	1015	15			Annealed	
	1020, 1023	20	12 024		Annealed	
		17G1S	11 523		Annealed	
F.1511	1015	15			Annealed	
F.1120	1025	25			Annealed	
					Annealed	
	A204 Grade A		15 020		Annealed	
	4520				Annealed	
	3310, 9314	20X2H4A	16 420		Annealed	
	4320		16 220		Annealed	
					Annealed	
F.1516	5115	12KHN2	14 220		Annealed	
		18HG			Annealed	
	5120	20KH	14 221		Annealed	
	5120 H	20KH			Annealed	
	A182-F11, A182-F12	12KHM	15 121		Annealed	
	A387 Grade 12 Cl. 2				Annealed	
F.155	A182-F22	12KH8	15 313		Annealed	
F.1130	1035	35	12 040		Annealed	
F.5110	1045	45	12 050		Annealed	
	1040	40	12 041		Annealed	
F.1150	1055	55			Annealed	
	1060	60	12 061		Annealed	
	1039	40G			Annealed	
	1330	30G2			Annealed	
F.1135	1035	35			Annealed	
F.1140	1045	45	12 050		Annealed	
F.1150	1064	60			Annealed	
	1060	60			Annealed	
F.144	9255	55S2			Annealed	
F.1250	4135	35KHM			Annealed	
F.5241	S1	5KHV2S			Annealed	
	L6	5KHNV			Annealed	
	5045				Annealed	
	3135				Quenched & Tempered	
	3435				Annealed	
	9840				Quenched & Tempered	
F.1280	4340	38H2N2MA	16 343		Annealed	
	5132	35KH			Quenched & Tempered	
	5140	40H	14 140		Quenched & Tempered	
F.1251	4130	20KHM	15 130		Quenched & Tempered	
F.1252	4142, 4140	38HM	15 142		Annealed	
F.1252	4142, 4140	38HM	15 142		Quenched & Tempered	
					Quenched & Tempered	
F.143	6150	50KHFA	15 260		Quenched & Tempered	
F.1740	A355 Cl. A				Annealed	
F.5103	1070	70			Annealed	
F.5117	1095				Annealed	
F.5118	W1	U10A			Annealed	
		U10			Annealed	
	W1	U13			Annealed	

SMG

SMG	EN	EN-Nr	W.-Nr	DIN	AFNOR	BS	UNI	JIS	SS	UNS
P7	107 CrV 3	1.2210	1.2210	115 CrV 3	100 C 3		107 CrV 3 KU			T61202
			1.2510	100 MnCrW 4	90 MWCV 5	BO 1	95 MnWCr 5 KU	SKS 3	2140	T31501
	90 MnCrV 8	1.2842	1.2842	90 MnCrV 8	90 MV 8	BO 2	90 MnVCr 8 KU			T31502
	100 Cr 6	1.3505	1.3505	100 Cr 6	100 C 6	534 A 99	100 Cr 6	SUJ 2	2258	G51986
P8	X 210 Cr 12	1.2080	1.2080	X 210 Cr 12	Z 200 C 12	BD 3	X 210 Cr 13 KU	SKD 1		T30403
			1.2343	X 38 CrMoV 5 1	Z 38 CDV 5	BH 11	X 37 CrMoV 5 1 KU	SKD 6		T20811
	X 40 CrMoV 5 1	1.2344	1.2344	X 40 CrMoV 5 1	Z 40 CDV 5	BH 13	X 40 CrMo 5 1 1 KU	SKD 61	2242	T20813
	X 100 CrMoV 5	1.2363	1.2363	X 100 CrMoV 5 1	Z 100 CDV 5	BA 2	X 100 CrMoV 5 1 KU	SKD 12	2260	T30102
			1.2365	X 32 CrMoV 3 3	32 DCV 28	BH 10	30 CrMoV 12 27 KU	SKD 7		T20810
			1.2436	X 210 CrW 12			X 215 CrW 12 1 KU	SKD 2	2312	
			1.2601	X 165 CrMoV 12			X 165 CrMoV 12 KU		2310	
			1.2713	55 NiCrMoV 6	55 NCDV 7			SKT 4		T61206
	HS 6-5-2-5	1.3243	1.3243	S 6-5-2-5	Z 85 WDKCV 06-05-04-02		HS 6-5-2-5	SKH 55	2723	
	HS 2-10-1-8	1.3247	1.3247	S 2-10-1-8	Z 110 DKCWX 09-08-04	BM 42	HS 2-9-1-8	SKH 51		T11342
	HS 18-1-2-5	1.3255	1.3255	S 18-1-2-5	Z 80 WKCX 18-05-04-01	BT 4	HS 18-1-1-5	SKH 3		T12004
	HS 6-5-2	1.3343	1.3343	S 6-5-2	Z 85 WDCV 06-05-04-02	BM 2	HS 6-5-2	SKH 9, SKH 51	2722	T11302
HS 2-9-2	1.3348	1.3348	S 2-9-2	Z 100 DCWV 09-04-02-02		HS 2-9-2	SKH 58	2782	T11307	
HS 18-0-1	1.3355	1.3355	S 18-0-1	Z 80 WCV 18-04-01	BT 1	HS 18-0-1	SKH 2		T12001	
P11	X 6 Cr 13	1.4000	1.4000	X 6 Cr 13	Z 6 C 12	403 S 17	X 6 Cr 13	SUS 403	2301	S41008
	X 12 Cr 13	1.4006	1.4006	X 10 Cr 13	Z 10 C 13	410 S 21	X 12 Cr 13	SUS 410	2302	S41000
	X 6 Cr 17	1.4016	1.4016	X 6 Cr 17	Z 8 C 17	430 S 15	X 8 Cr 17	SUS 430	2320	S43000
	X 20 Cr 13	1.4021	1.4021	X 20 Cr 13	Z 20 C 13	420 S 37	X 20 Cr 13	SUS 420 J 1	2303	S42000
	X 39 Cr 13	1.4031	1.4031	X 40 Cr 13	Z 40 C 14	420 S 45	X 40 Cr 14	SUS 420	2304	S40280
	X 70 CrMo 15	1.4109	1.4109	X 65 CrMo 14	Z 70 D 14			SUS 440 A		S44002
	X 90 CrMoV 18	1.4112	1.4112	X 90 CrMoV 18	Z 2 CND 18 05	409 S 19	X CrTi 12	SUS 440 B	2327	S44003
	X 105 CrMo 17	1.4125	1.4125	X 105 CrMo 17	Z 100 CD 17		X 105 CrMo 17	SUS 440 C		S44004
	X 3 CrNiMo 13 3	1.4313	1.4313	X 5 CrNi 13 4	Z 5 CN 13.4	425 C 11	X 6 CrNi 13 04	SCS 5	2385	S41500
	X 18 CrN 28	1.4749	1.4749	X 18 CrN 28	Z 18 C 25				2322	S44600
	X 6 NiCrTiMoV 25 15	1.4534	1.4534	X 3 CrNiMoAl 13 8 2						S13800
P12	X 4 CrNiCuNb 16 4	1.4540	1.4540	X 4 CrNiCuNb 16 4						S15500
		1.4540	1.4540	X 4 CrNiCuNb 16 4	Z 4 CNUNb 16.4 M					S15500
	X 4 CrNiCuNb 16 4	1.4540	1.4540	X 4 CrNiCuNb 16 4						S15500
	X 5 CrNiCuNb 16 4	1.4542	1.4542	X 5 CrNiCuNb 16 4				SUS 630		S17400
	X 5 CrNiCuNb 17 4	1.4548	1.4542	X 5 CrNiCuNb 17 4	Z 6 CNU 17.4			SCS 24, SUS 630		S17400
	X 7 CrNiAl 17 7	1.4564	1.4564	X 7 CrNiAl 17 7	Z 9 CAN 17.7	301 S 81	X 7 CrNiAl 17 7	SUS 631	2388	S17700
	X 2 NiCoMoTi 18 12 4	1.6356	1.6356	X 2 NiCoMoTi 18 12 4						K93160
	X 2 NiCoMoTi 18 9 5	1.6358	1.6358	X 2 NiCoMoTi 18 9 5	Z 2 NKD 19-09					K93120
	X 2 NiCoMo 18 9 5	1.6358	1.6358	X 2 NiCoMoTi 18 9 5	Z 2 NKD 19-09					K93120
	X 2 NiCoMo 18 8 5	1.6359	1.6359	X 2 NiCoMo 18 8 5		S 162				K92890
X 2 NiCoMo 18 8 5	1.6359	1.6359	X 2 NiCoMo 18 8 5		S 162				K92890	
M1	X 10 CrNiS 18 9	1.4305	1.4305	X 10 CrNiS 18 9	Z 10 CNF 18.09	303 S 31	X 10 CrNi 18 09	SUS 303	2346	S30300
	X 2 CrNi 19 11	1.4306	1.4306	X 2 CrNi 19 11	Z 2 CN 18.10	304 S 12	X 3 Cr Ni 18 11	SUS 304 L	2352	S30403
M2	X 5 CrNi 18 10	1.4301	1.4301	X 5 CrNi 18 10	Z 6 CN 18.09	304 S 31	X 5 CrNi 18 11	SUS 304	2333	S30400
	X 5 CrNiMo 17 12 2	1.4401	1.4401	X 5 CrNiMo 17 12 2	Z 3 CND 17.11.1	316 S 31	X 5 CrNiMo 17 12	SUS 316	2347	S31600
	X 6 CrNiNb 18 10	1.4550	1.4550	X 6 CrNiNb 18 10	Z 6 CNNb 18.10	347 S 31	X 6 CrNiNb 18 11	SUS 347	2338	S34700
	X 9 CrNi 18 8	1.4310	1.4310	X 12 CrNi 17 7	Z 12 CN 17.07	301 S 21	X 12 CrNi 17 07	SUS 301	(2331)	S30100
	X 12 CrNi 18 8	1.4300	1.4300	X 12 CrNi 18 8	Z 12 CN 18	302 S 25		SUS 302	2331	S30200
M3	X 2 CrNiMo 18 14 3	1.4435	1.4435	X 2 CrNiMo 18 14 3	Z 2 CND 17.13	316 S 12	X 2 CrNiMo 17 13 2	SCS 16, SUS 316 L	2353	S31603
	X 2 CrNiMoN 17 13 3	1.4429	1.4429	X 2 CrNiMoN 17 13 3	Z 2 CND 17.13 Az	316 S 62	X 2 CrNiMoN 17 13 3	SUS 316 LN	2375	S31653
	X 2 CrNiN 18 10	1.4311	1.4311	X 2 CrNiN 19 11	Z 2 CN 18. 10 Az	304 S 62	X 2 CrNiN 18 11	SUS 304 LN	2371	S30453
	X 3 CrNiMo 18 12 3	1.4466	1.4466	X 5 CrNi 18 15		317 S 16	X 5 CrNi 18 15	SUS 317	2366	S31700
	X 9 CrNiSiNCo 21 11 2	1.4835	1.4893	X 9 CrNiSiNCo 21 11 2		310 S 31			2368	S30815
M4	X 12 CrNi 25 21	1.4335	1.4335	X 12 CrNi 25 21	Z 12 CN 25.20	310 S 24	X 6 CrNi 26 20	SUH 310, SUS 310 S	2361	S31008
	X 2 CrNiMo 22 5 3	1.4462	1.4462	X 2 CrNiMoN 22 5	Z 2 CND 22.05 Az	332 S 15	X 2 CrNiMo 22 5		2377	S31803
	X 2 CrNiMoSi 19 5	1.4424	1.4417	X 2 CrNiMoSi 19 5	Z 2 CND 18.05.03				2376	S31500
	X 2 NiCrMoCu 25 20 5	1.4539	1.4539	X 2 NiCrMoCu 25 20 5	Z 2 NCDU 25 20	904 S 13			2562	N08904
	X 3 CrNiMo 27 5 2	1.4460	1.4460	X 4 CrNiMo 27 5 2	Z 3 CND 25.7 Az		X 3 CrNiMo 27 5 2	SUS 329 J 1	2324	S32900
M5	X 5 CrNiCuNb 16 4	1.4980	1.4943	X 4 NiCrTi 25 15	Z 6 NCTDV 25.15	HR 51		SUH 660	2570	S66286
	X 1 CrNiMoN 20 18 7	1.4547	1.4529	X 1 CrNiMoN 20 18 7	Z 1 CNDU 20.18.05 Az		X 1 CrNiMoN 20 18 7		2778	S31254
	X 1 CrNiMo 25 22 8	1.4652	1.4652	X 2 CrNiMoN 25 22 7						S32654
	X 10 NiCrAlTi 32 20	1.4876	1.4876	X 10 NiCrAlTi 32 20	Z 10 NC 32.21			NCF 800		N08800
	X 2 CrNiMoN 25 7 4	1.4410	1.4410	X 2 CrNiMoN 25 7 4	Z 3 CND 25.07 Az		X 2 CrNiMoN 25 7 4		2328	S32750

SMG

U.N.E./ I.H.A.	AISI / ASTM	GOST	ČSN	Misc. Brands	Condition	Structure
F.520L	L2	11KHF			Annealed	
F.5220	O1	9KHVG			Annealed	
	O2	9G2F			Annealed	
F.5230	52100	SHKH15	14 109		Annealed	
F.5212	D3	KH12			Annealed	
	H11	4KH5MFS			Annealed	
F.5318	H13	4KH5MF1S			Annealed	
F.5227	A2	9KH5VF			Annealed	
	H10	3KH3M3F			Annealed	
F.5213		KH12			Annealed	
		KH12MF			Annealed	
F.520.S	L6	5KHNM			Annealed	
F.5613	M35	R6M5K5			Annealed	
	M42	R2AM9K5			Annealed	
	T4	R18K5F2			Annealed	
F.5603	M2	R6M5			Annealed	
	M7				Annealed	
	T1	R18			Annealed	
	403	08KH13			Annealed	Ferritic
F.3401	410, CA-15	12KH13, 08KH13			Annealed	Martensitic
F.3113	430	12KH17			Annealed	Ferritic
F.5261	420	20KH13	17 022		Annealed	Martensitic
F.3404	420	40KH13			Annealed	Martensitic
	440 A				Annealed	Martensitic
	440 B	95KH18			Annealed	Martensitic
	440 C	95KH18			Annealed	Martensitic
	A182 F6NM			F6NM	Annealed	Martensitic
	446	15KH28			Annealed	Ferritic
	XM-13			PH 13-8 Mo	Solution annealed	Austenitic
	XM-12			15-5 PH	H1150	Martensitic
	XM-12			15-5 PH	Solution annealed	Martensitic
	XM-12			15-5 PH	H1025	Martensitic
	SAE 630			17-4 PH	H1150	Martensitic
	630			17-4 PH	Solution annealed	Martensitic
	631	09KH17N7YU1		17-7 PH	Solution annealed	Austenitic/Ferritic
	AMS 6515			Marage 350	Solution annealed	Martensitic
	AMS 6521			Marage 300	Solution annealed	Martensitic
	AMS 6514			Marage 300, Vascomax C300	Solution annealed	Martensitic
	AMS 6512			Marage 250	Solution annealed	Martensitic
	AMS 6512			Marage 250, Vascomax C250	Solution annealed	Martensitic
F.3508	303	12KH19N9			Annealed	Austenitic
F.3504	304 L	03KH18N11			Annealed	Austenitic
F.3504	304	08KH18N10	17 240		Annealed	Austenitic
F.3534	316	08KH17H13M2T	17 346		Annealed	Austenitic
F.3524	347	08KH18N12B			Annealed	Austenitic
F.3517	301	07KH16N6			Annealed	Austenitic
	302	12KH18N9			Annealed	Austenitic
F.3533	(316 L)	03KH17N14M3	17 349		Annealed	Austenitic
	316 LN	03KH16N15M3			Annealed	Austenitic
F.3541	304 LN	03KH18N11			Annealed	Austenitic
	317	08KH17H15M3T			Annealed	Austenitic
				253 MA	Annealed	Austenitic
	310 S	12KH25N20			Annealed	Austenitic
	329 LN			SAF 2205	Annealed	Duplex
				3RE60	Annealed	Duplex
	904L				Annealed	Super austenitic
	329				Annealed	Duplex
	660			A286	Solution annealed	Austenitic
				254 SMO	Annealed	Super austenitic
				654 SMO	Annealed	Super austenitic
				Alloy 800	Annealed	Austenitic
	F 53			SAF 2507	Annealed	Super duplex

SMG

SMG	EN	EN-Nr	W.-Nr	DIN	AFNOR	BS	UNI	JIS	SS	UNS
K1	EN-GJL-150	0.6150	0.6150	GG-15	F1 15 D	Grade 150	G15	FC 150	01 15-00	F11601
	EN-GJL-200	0.6200	0.6200	GG-20	F1 20 D	Grade 220	G20	FC 200	01 20-00	F12101
	EN-GJL-250	0.6250	0.6250	GG-25	F1 25 D	Grade 260	G25	FC 250	01 25-00	F12401
	EN-GJL-350	0.6350	0.6350	GG-35	F1 35 D	Grade 350	G35	FC 350	01 35-00	F13502
	EN-GJL-215			GG-220 HB					02 19	
K2	EN-GJV-300			GJV-300						
	EN-GJV-350			GJV-350						
	EN-GJV-400			GJV-400						
	EN-GJV-450			GJV-450						
	EN-GJV-500			GJV-500						
K3	EN-GJMB-550-4	0.8155		GTS-55-04	P 540/5	P 540/5	P 55-04	PCMP55-04	08 54-00	F24130
K4	EN-GJS-350-22	0.7033	0.7033	GGG-35.3	FGS 370-17	Grade 350/22		FCD 350-22L	07 17-15	
	EN-GJS-400-15	0.7040	0.7040	GGG-40	FGS 400-12	Grade 420/12	GS 400-12	FCD 400-18L	07 17-02	F32800
	EN-GJS-400-18	0.7043	0.7043	GGG-40.3	FGS 370-17	Grade 370/17	GSO 42/17		07 17-12	F32800
	EN-GJS-500-7	0.7050	0.7050	GGG-50	FGS 500-7	Grade 500/7	GS 500-7	FCD 500-7	07 27-02	F33800
	EN-GJS-600-3	0.7060	0.7060	GGG-60	FGS 600-3	Grade 600/3	GS 600-3	FCD 600-3	07 32-03	F34100
	EN-GJS-700-2	0.7070	0.7070	GGG-70	FGS 700-2	Grade 700/2	GS 700-2	FCD 700-2	07 37-01	F34800
K5	EN-GJS-1000-5			GJS-1000-5						ADI grade 5
	EN-GJS-1200-2			GJS-1200-2						ADI grade 2
	EN-GJS-1400-1			GJS-1400-1						ADI grade 3
	EN-GJS-800-8			GJS-800-8						ADI grade 4
K6	EN-GJLA-XNiCr 20-2	0.6660	0.6660	GGL-NiCr 20 2	FGL Ni20 Cr2	Grade F2			05 23-00	F41002
	EN-GJLA-XNiCr 30-3	0.6676	0.6676	GGL-NiCr 30 3	FGL Ni30 Cr3	Grade F3				F41004
	EN-GJLA-XNiCuCr 15-6-2	0.6655	0.6655	GGL-NiCuCr 15 6 2	FGL Ni15 Cu6 Cr2	Grade F1				F41000
K7	EN-GJSA-XNiMn 13-7	0.7652	0.7652	GGG-NiMn 13 7	FGS Ni13 Mn7	Grade S6			07 72-00	
	EN-GJSA-XNiCr 20-2	0.7660	0.7660	GGG-NiCr 20 2	FGS Ni20 Cr2	Grade S2				F43000
	EN-GJSA-XNiMn 23-4	0.7673	0.7673	GGG-NiMn 23 4	FGS Ni23 Mn4	Grade S2M				F43010
	EN-GJSA-XNiCr 30-3	0.7676	0.7676	GGG-NiCr 30 3	FGS Ni30 Cr3	Grade S3				F43003
	EN-GJSA-XNi 35	0.7683	0.7683	GGG-Ni 35	FGS Ni35					F43006
N1	AW-1050A	Al99.5	3.0255	Al99.5	A-5/1050A	1B		(A1050)	4007	AA1050A
	AW-2011	AlCuBiPb	3.1655	AlCuBiPb	A-U5PbBi/2011	FC1		A2011	4355	AA2011
	AW-2014	AlCuSiMn	3.1255	AlCuSiMn	A-U4SG/2014	H15			4338	AA2014
	AW-5005	AlMg1	3.3315	AlMg1	A-G0.6	N41			4106	AA5005
	AW-6060	AlMgSi0.5	3.3206	AlMgSi0.5	A-GS/6060	(H9)			4103	AA6060
	AW-6063	AlMgSi0.7	3.3210	AlMgSi0.7	A-GSUC/6061	(H10)		(A6063)	4104, 4107	AA6005
	AW-3103	AlMn1	3.0515	AlMn1		N3			4054	AA3103
	AW-3003	AlMn1Cu	3.0517	AlMn1Cu	A-M1/3003			A3003		AA3003
	AW-7020	AlZn4.5Mg1	3.4335	AlZn4.5Mg1	A-Z5G/7020	H17			4425	AA7020
	AW-7075		3.4365	AlZnMgCu1.5	A-Z5GU/7075	2L95/2L96			A7075	AA7075
	AC-42000		3.2341	G-AlSi5Mg	A-S7G	LM25	3599		AC 4C	4244
	AC-46200	AlSi8Cu3(Si)	3.2161	G-AlSi8Cu3					4251	A13800
	MG-P-63	MgAl6Zn	3.5612	G-MgAl6Zn	G-A6-Z1	MAG-E-121				M11600
	MG-P-61	MgAl8Zn	3.5812	G-MgAl8Zn	(G-A7-Z1)					
	MN65120	MgSe3Zn2Zr1	3.5103	G-MgSe3Zn2Zr1	ZRE1	MAG6-TE				M12330
N2	AC-43400	AlSi10Mg(Fe)	3.2381	G-AlSi10Mg	A-S10G	LM9			4253	A13600
	AC-44200	AlSi12	3.2382	GD-AlSi12						
	AW-6082	AlMgSi1	3.2315	AlMgSi1	A-SGM0.7/6082	H30			4212	AA6082
N3		AlSi17Cu5						ADC14		
N11	CC331G		2.0940.01	CuAl10Fe	CuAl10Fe	AB1			5710	C95200
	CC333G		2.0975.01	CuAl10Ni	CuAl10Ni5Fe5	AB2			5716	C95500
		CuNi10Fe1Mn	2.0872	CuNi10Fe1Mn	CuNi10Fe1Mn	CN102			5667	C70600
				CuNi10Zn45						
		CW408J	2.0790	CuNi18Zn19Pb	CuNi18Zn19Pb1					C76300
	CW352H		2.1176	CuPb10Sn	CuSn10Pb10	LB2			5640	C93700
	CC480K		2.1050.01	CuSn10	CuSn10	CT1			5443	C90700
			2.1087	CuSn10Zn					5458	C90500
	CW452K	CuSn6	2.1020	CuSn6	CuSn6	PB103		C5191	5428	C51900
	CW502L	CuZn15	2.0240	CuZn15	CuZn15	CZ102		C2300	5112	C23000
	CW706R	CuZn28Sn1	2.0470	CuZn28Sn1	CuZn29Sn1				5220	C44300
	CW508L	CuZn37	2.0321	CuZn37	CuZn37	CZ108			5150	C27200
	CW717R	CuZn38Sn1	2.0530	CuZn38Sn1						C46400
	CW614N	CuZn39Pb3	2.0401	CuZn39Pb3	CuZn39Pb3	CZ121			5170	C38500
	CW612N	CuZn40Pb2	2.0402	CuZn40Pb2	CuZn39Pb2	CZ120			5168	C37800
CW622N	CuZn44Pb2	2.0410	CuZn44Pb2		CZ104			5272	C68700	

SMG

SMG	EN	EN-Nr	W-Nr	DIN	AFNOR	BS	UNI	JIS	SS	UNS	
S1											
S2											
S3	NiMo30		2.4810							N10002	
	NiMo16Cr15W		2.4819							N10276	
	NiCr19Fe19Nb5Mo3		2.4668							N07718	
	NiCr20TiAl		2.4631							N07080	
	NiCr19Co18Mo4Ti3Al3									N07500	
	NiCr20Co13Mo4Ti3Al		2.4654							N07001	
S11			3.7024							R54620	
S12	TiAl6V4		3.7164							R56320 R56400	
S13				TiV10Fe2Al3							
H3	16 MnCr 5	1.7131	1.7131	16 MnCr 5	16 MC 5	527 M 17	16 MnCr 5	SCR 415	2511	G51170	
	C 67S	1.1231	1.1231	Ck 67	XC 68	060 A 67	C 70		1770	G10700	
H5	C 75S	1.1248	1.1248	Ck 75	XC 75	060 A 78	C 75		1774, 1778	G10780	
	C 100S	1.1274	1.1274	Ck 101		060 A 96		SUP 4	1870	G10950	
	C 105U	1.1545	C 105 W1	Y1 105			C 100 KU		1880		
			1.2550	60 WCrV 7	55 WC 20		55 WCrV 8 KU				
	55 Cr 3	1.7176	1.7176	55 Cr 3	55 C 3	527 A 60	55 Cr 3	SUP 9 (A)	2253	G51550	
	42 CrMo 4	1.7225	1.7225	42 CrMo 4	42 CD 4	708 M 40	42 CrMo 4	SCM 440 (H)	2244	G41400	
H7	107 CrV 3	1.2210	1.2210	115 CrV 3	100 C 3		107 CrV 3 KU			T61202	
			1.2510	100 MnCrW 4	90 MWCV 5	BO 1	95 MnWCr 5 KU	SKS 3	2140	T31501	
	90 MnCrV 8	1.2842	1.2842	90 MnCrV 8	90 MV 8	BO 2	90 MnVCr 8 KU			T31502	
	100 Cr 6	1.3505	1.3505	100 Cr 6	100 C 6	534 A 99	100 Cr 6	SUJ 2	2258	G51986	
H8	X 40 CrMoV 5 1	1.2344	1.2344	X 40 CrMoV 5 1	Z 40 CDV 5	BH 13	X 40 CrMo 5 1 1 KU	SKD 61	2242	T20813	
	X 100 CrMoV 5	1.2363	1.2363	X 100 CrMoV 5 1	Z 100 CDV 5	BA 2	X 100 CrMoV 5 1 KU	SKD 12	2260	T30102	
	X 155 CrVMo 12 1		1.2379	X 155 CrVMo 12 1	Z 160 CDV 12	BD 2	X 155 CrVMo 12 1 KU	SKD 11		T30402	
			1.2436	X 210 CrW 12			X 215 CrW 12 1 KU	SKD 2		2312	
			1.2601	X 165 CrMoV 12			X 165 CrMoW 12 KU			2310	
			1.2713	55 NiCrMoV 6	55 NCDV 7			SKT 4			T61206
	HS 6-5-2-5	1.3243	1.3243	S 6-5-2-5	Z 85 WDKCV 06-05-05-04-02		HS 6-5-2-5	SKH 55	2723		
HS 2-10-1-8	1.3247	1.3247	S 2-10-1-8	Z 110 DKCWV 09-08-	BM 42	HS 2-9-1-8	SKH 51			T11342	
HS 18-0-1	1.3355	1.3355	S 18-0-1	Z 80 WCV 18-04-01	BT 1	HS 18-0-1	SKH 2			T12001	
H11	X 20 Cr 13	1.4021	1.4021	X 20 Cr 13	Z 20 C 13	420 S 37	X 20 Cr 13	SUS 420 J 1	2303	S42000	
	X 70 CrMo 15	1.4109	1.4109	X 65 CrMo 14	Z 70 D 14			SUS 440 A		S44002	
	X 90 CrMoV 18	1.4112	1.4112	X 90 CrMoV 18	Z 2 CND 18 05	409 S 19	X CrTi 12	SUS 440 B	2327	S44003	
	X 105 CrMo 17	1.4125	1.4125	X 105 CrMo 17	Z 100 CD 17		X 105 CrMo 17	SUS 440 C		S44004	
H12	X 4 CrNiCuNb 16 4	1.4540	1.4540	X 4 CrNiCuNb 16 4						S15500	
	X 5 CrNiCuNb 16 4	1.4542	1.4542	X 5 CrNiCuNb 16 4				SUS 630		S17400	
	X 5 CrNiCuNb 16 4	1.4542	1.4542	X 5 CrNiCuNb 16 4				SUS 630		S17400	
	X 7 CrNiAl 17 7	1.4568	1.4568	X 7 CrNiAl 17 7	Z 9 CAN 17.7	301 S 81	X 7 CrNiAl 17 7	SUS 631	2388	S17700	
	X 8 CrNiMoAl 15 7 5	1.4574	1.4574	X 8 CrNiMoAl 15 7 5						S15700	
	X 6 NiCrTiMoV 25 15	1.4980	1.4943	X 4 NiCrTi 25 15	Z 6 NCTDV 25.15	HR 51		SUH 660	2570	S66286	
	X 2 NiCoMo 18 8 5	1.6359	1.6359	X 2 NiCoMo 18 8 5		S 162				K92890	
	X 2 NiCoMoTi 18 9 5	1.6358	1.6358	X 2 NiCoMoTi 18 9 5	Z 2 NKD 19-09					K93120	
X 2 NiCoMoTi 18 9 5	1.6358	1.6358	X 2 NiCoMoTi 18 9 5	Z 2 NKD 19-09					K93120		
X 2 NiCoMoTi 18 12 4	1.6356	1.6356	X 2 NiCoMoTi 18 12 4						K93160		
H21	X 120 Mn 12	1.3401	1.3401	X 120 Mn 12	Z 120 M 12	BW 10		SC MnH 1	2183		
H31	EN-GJN-HV520	0.9620	0.9620	G-X330 NiCr 4 2	FB Ni4 Cr2 BC	Grade 2 A			05 12-00	F45001	
	EN-GJN-HV550	0.9625	0.9625	G-X260 NiCr 4 2	FB Ni4 Cr2 HC	Grade 2 B			05 13-00	F45000	
	EN-GJN-HV600(XCr11)	0.9630	0.9630	G-X300 CrNiSi 9 5 2	FB Cr9 Ni5	Grade 2 C, D, E			04 57-00	F45003	

SMG

U.N.E./I.H.A.	AISI / ASTM	GOST	ČSN	Misc. Brands	Condition	Structure
				Discalloy	Precipitation hardened	
				Haynes 25		
				Stellite 21		
				Hastelloy C		
		KHN65MV		Hastelloy C-276		
				IN 100		
				Inconel 718		
				Inconel X-750	Solution annealed	
				Nimonic 80A		
				René 41		
				Udimet 500		
				Waspalloy		
				Ti	Commercially pure	Ti (α)
	AMS 4919			Ti 6-2-4-2	Annealed	Ti (α)
	AMS 4943			Ti 3Al-2.5V (grd 9)	Annealed	Ti (α+β)
	AMS 4920, Grade 5	VT6		Ti 6Al-4V	Annealed	Ti (α+β)
	AMS 4986			Ti 10V-2Fe-3Al	Annealed	Ti (β)
F.1516	5115	12KHN2	14 220		Case hardened	
F.5103	1070	70			Quenched & Tempered	
F.5107	1078, 1080	75			Quenched & Tempered	
F.5117	1095				Quenched & Tempered	
F.5118	W1	U10A			Quenched & Tempered	
	S1	5KHV2SF			Quenched & Tempered	
	5155				Quenched & Tempered	
F.1252	4142, 4140	38HM	15 142		Quenched & Tempered	
F.520L	L2	11KHF			Quenched & Tempered	
F.5220	O1	9KHVG			Quenched & Tempered	
	O2	9G2F			Quenched & Tempered	
F.5230	52100	SHKH15	14 109		Quenched & Tempered	
F.5318	H13	4KH5MF1S			Quenched & Tempered	
F.5227	A2	9KH5VF			Quenched & Tempered	
F.5211	D2	KH12MF			Quenched & Tempered	
F.5213		KH12			Quenched & Tempered	
		KH12MF			Quenched & Tempered	
F.520.S	L6	5KHNM			Quenched & Tempered	
F.5613	M35	R6M5K5			Quenched & Tempered	
	M42	R2AM9K5			Quenched & Tempered	
	T1	R18			Quenched & Tempered	
F.5261	420	20KH13	17 022		Quenched & Tempered	Martensitic
	440 A				Quenched & Tempered	Martensitic
	440 B	95KH18			Quenched & Tempered	Martensitic
	440 C	95KH18			Quenched & Tempered	Martensitic
	XM-12			15-5 PH	H900	Martensitic
	SAE 630			17-4 PH	H1025	Martensitic
	SAE 630			17-4 PH	H900	Martensitic
	AMS 5528	09KH17N7YU1		17-7 PH	TH1050	Martensitic
	632			PH 15-7 Mo	TH1050	Martensitic
	660			A286	Precipitation hardened	Austenitic
	AMS 6512			Marage 250	Precipitation hardened	Martensitic
	AMS 6521			Marage 300	Precipitation hardened	Martensitic
	AMS 6521			Marage 300	Precipitation hardened	Martensitic
	AMS 6515			Marage 350	Precipitation hardened	Martensitic
	A128 Grade A			Hadfield		
	A532 IB (NiCr-LC)			Ni-Hard 2		White cast iron
	A532 IA (NiCr-HC)			Ni-Hard 1		White cast iron
	A532 ID (Ni-HiCr)			Ni-Hard 4		White cast iron

This work is published with the understanding that Seco Tools and its editors are supplying information aimed to present a general orientation and direction of metal cutting and related sciences. If professional services are required for specific applications, the assistance of an appropriate professional should be acquired.

The information is provided “as is”;
Seco Tools and its editors disclaim all representations and warranties, express or implied, of any kind, including, without limitations, any warranties of merchantability, fitness for a particular purpose, title, or non-infringement. In no event will Seco Tools or its editors be liable to any party for any direct, indirect, special or other consequential damages for any use of the information, even if Seco Tools or its editors are advised of the possibility of such damage.

The information provided herein is for reference purposes only. Actual prices, specifications, and product descriptions are finalised at the time of sale and may vary by location.
The information provided herein is subject to change without prior notice.

WWW.SECOTOOLS.COM

03334633, ST20196721 GB,
© SECO TOOLS AB, 2020. All rights reserved.
Technical specifications are subject to
change without notice.